

VERSION FULLY LOADED

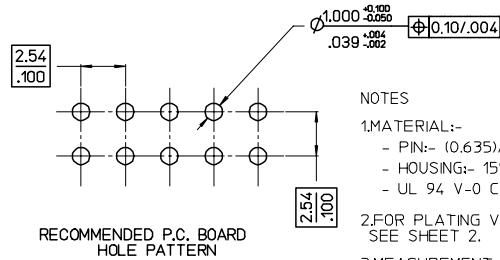
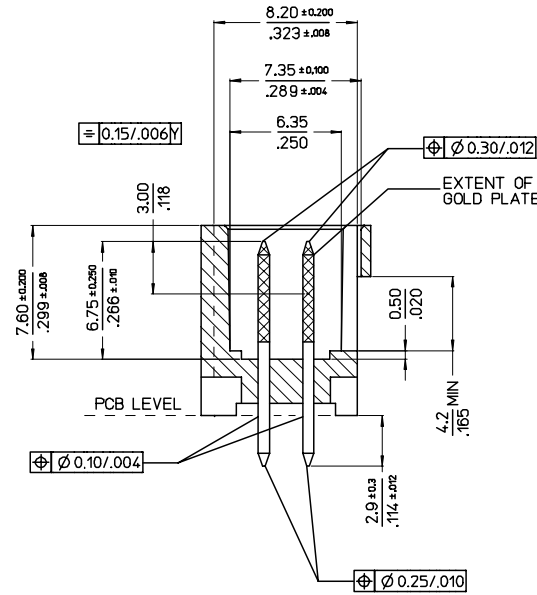
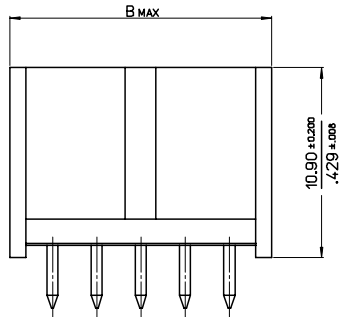
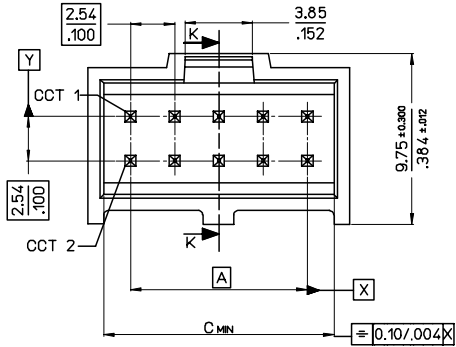

NOTES

- 1.MATERIAL:-
 - PIN:- (0.635)/.025 SQ. BRASS WIRE.
 - HOUSING:- 15% GLASS FILLED POLYESTER
 - UL 94 V-0 COLOUR BLACK
- 2.FOR PLATING VERSIONS AND VOID VERSIONS SEE SHEET 2.
- 3.MEASUREMENT POINT FOR MINIMUM PLATING THICKNESS.
- 4.FOR PRODUCT SPEC SEE PS-99020-0001
- 5.RECOMMENDED PCB THICKNESS: 1.6mm

No. OF CKTS	DIM A	DIM B	DIM C
6	(5.08) / .200	(9.96) / .392	(8.12) / .320
8	(7.62) / .300	(12.50) / .492	(10.66) / .420
10	(10.16) / .400	(15.04) / .592	(13.20) / .520
12	(12.70) / .500	(17.58) / .692	(15.74) / .620
14	(15.24) / .600	(20.12) / .792	(18.28) / .720
16	(17.78) / .700	(22.66) / .892	(20.82) / .820
18	(20.32) / .800	(25.20) / .992	(23.36) / .920
20	(22.86) / .900	(27.74) / 1.092	(25.90) / 1.020
22	(25.40) / 1.000	(30.28) / 1.192	(28.44) / 1.120
24	(27.94) / 1.100	(32.82) / 1.292	(30.98) / 1.220
26	(30.48) / 1.200	(35.36) / 1.392	(33.52) / 1.320
28	(33.02) / 1.300	(37.90) / 1.492	(36.06) / 1.420
30	(35.56) / 1.400	(40.44) / 1.592	(38.60) / 1.520
32	(38.10) / 1.500	(42.98) / 1.692	(41.15) / 1.620
34	(40.64) / 1.600	(45.52) / 1.792	(43.68) / 1.720
36	(43.18) / 1.700	(48.06) / 1.892	(46.22) / 1.820
38	(45.72) / 1.800	(50.60) / 1.992	(48.76) / 1.920
40	(48.26) / 1.900	(53.14) / 2.092	(51.30) / 2.020
42	(50.80) / 2.000	(55.68) / 2.192	(53.84) / 2.120
44	(53.34) / 2.100	(58.22) / 2.292	(56.38) / 2.220
46	(55.88) / 2.200	(60.76) / 2.392	(58.92) / 2.320
48	(58.42) / 2.300	(63.30) / 2.492	(61.46) / 2.420
50	(60.96) / 2.400	(65.84) / 2.592	(64.00) / 2.520
52	(63.50) / 2.500	(68.38) / 2.692	(66.54) / 2.620
54	(66.04) / 2.600	(70.92) / 2.792	(69.08) / 2.720
56	(68.58) / 2.700	(73.46) / 2.892	(71.62) / 2.820
58	(71.12) / 2.800	(76.00) / 2.992	(74.16) / 2.920
60	(73.66) / 2.900	(78.54) / 3.092	(76.70) / 3.020
62	(76.20) / 3.000	(81.08) / 3.192	(79.24) / 3.120
64	(78.74) / 3.100	(83.62) / 3.292	(81.78) / 3.220
66	(81.28) / 3.200	(86.16) / 3.392	(84.32) / 3.320
68	(83.82) / 3.300	(88.70) / 3.492	(86.86) / 3.420

REMOVED NATURAL ELC NO. E2008-0083 DRW:NB/FRNES CHKD: APPR:ECM/AMNY 2007/08/28 2007/09/06 2007/09/07	QUALITY SYMBOLS =0 =0	GENERAL TOLERANCES (UNLESS SPECIFIED) mm INCH 4 PLACES ± --- ± --- 3 PLACES ± --- ±.004 2 PLACES ± 0.10 ± --- 1 PLACE ± --- ± --- ANGULAR ±1/2°	DIMENSION STYLE MM/IN DRAWN BY DATE KS 1988/08/23 CHECKED BY DATE APPROVED BY DATE	SCALE 5:1 DESIGN UNITS METRIC THIRD ANGLE PROJECTION	C-GRID III DUAL ROW STRAIGHT SHROUDED HEADER MOLEX INCORPORATED	MATERIAL NO. SEE CHART DOCUMENT NO. SDA-90130	SHEET NO. 1 OF 4
	DRAFT WHERE APPLICABLE MUST REMAIN WITHIN DIMENSIONS	THIS DRAWING CONTAINS INFORMATION THAT IS PROPRIETARY TO MOLEX INCORPORATED AND SHOULD NOT BE USED WITHOUT WRITTEN PERMISSION					

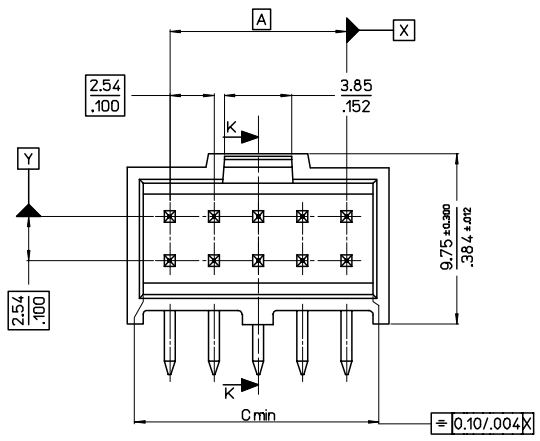

VERSION FULLY LOADED

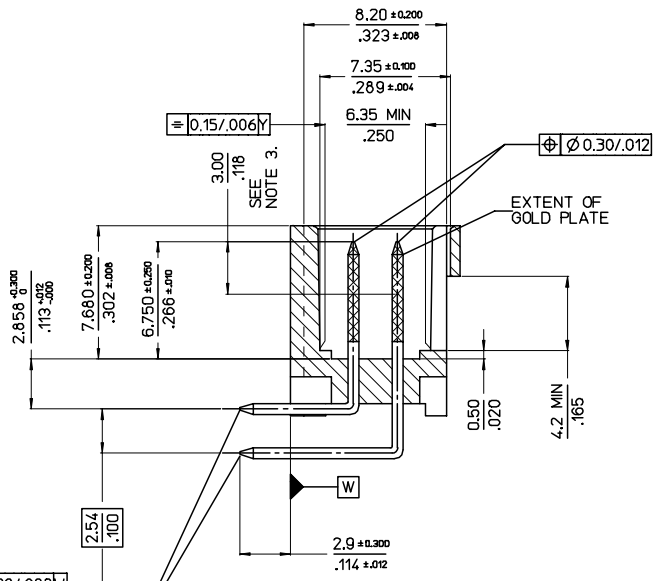
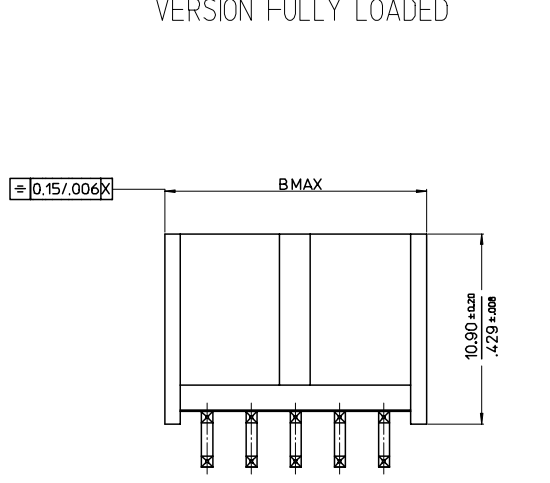

HSG CKT SIZE	A	B	C
6	(5.08) .200	(10.34) .407	(7.92) .312
8	(7.62) .300	(12.88) .507	(10.46) .412
10	(10.16) .400	(15.42) .607	(13.00) .512
12	(12.70) .500	(17.96) .707	(15.54) .612
14	(15.24) .600	(20.50) .807	(18.08) .712
16	(17.78) .700	(23.04) .907	(20.62) .812
18	(20.32) .800	(25.58) 1.007	(23.16) .912
20	(22.86) .900	(28.12) 1.107	(25.70) 1.012
22	(25.40) 1.000	(30.66) 1.207	(28.24) 1.112
24	(27.94) 1.100	(33.20) 1.307	(30.78) 1.212
26	(30.48) 1.200	(35.74) 1.407	(33.32) 1.312
28	(33.02)/1.300	(37.90)/1.492	(36.06)/1.420
30	(35.56) 1.400	(40.82) 1.607	(38.40) 1.512
32	(38.10)/1.500	(42.98)/1.692	(41.15)/1.620
34	(40.64) 1.600	(45.90) 1.807	(43.48) 1.712
36	(43.18)/1.700	(48.06)/1.892	(46.22)/1.820
38	(45.72) 1.800	(50.98) 2.007	(48.56) 1.912
40	(48.26) 1.900	(53.52) 2.107	(51.10) 2.012
42	(50.80)/2.000	(55.68)/2.192	(53.84)/2.120
44	(53.34) 2.100	(58.60) 2.307	(56.18) 2.212
46	(55.88)/2.200	(60.76)/2.392	(58.92)/2.320
48	(58.42)/2.300	(63.30)/2.492	(61.46)/2.420
50	(60.96) 2.400	(66.22) 2.607	(63.80) 2.512
52	(63.50)/2.500	(68.38)/2.692	(66.54)/2.620
54	(66.04) 2.600	(71.30) 2.807	(68.88) 2.712
56	(68.58)/2.700	(73.46)/2.892	(71.62)/2.820
58	(71.12)/2.800	(76.00)/2.992	(74.16)/2.920
60	(73.66) 2.900	(78.92) 3.107	(76.50) 3.012
62	(76.20)/3.000	(81.08)/3.192	(79.24)/3.120
64	(78.74) 3.100	(84.00) 3.307	(81.58) 3.212
66	(81.28)/3.200	(86.16)/3.392	(84.32)/3.320
68	(83.82) 3.300	(89.08) 3.507	(86.66) 3.412

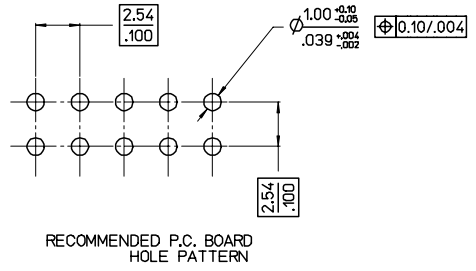

- NOTES
- MATERIAL:-
 - PIN:- (0.635)/.025 SQ. BRASS WIRE.
 - HOUSING:- 15% GLASS FILLED POLYESTER
 - UL 94 V-0 COLOUR BLACK
 - FOR PLATING VERSIONS AND VOID VERSIONS SEE SHEET 2.
 - MEASUREMENT POINT FOR MINIMUM PLATING THICKNESS.
 - FOR PRODUCT SPEC SEE PS-99020-0001
 - RECOMMENDED PCB THICKNESS: 1.6mm

MODIFIED TITLE: ELC NO: E2008-0083 2007/08/28 DRAWN: LIBRINES 2007/09/06 CHKD: 2007/09/06 APPR: EGMADHONY 2007/09/07	QUALITY SYMBOLS ▽=0 ▽=0	GENERAL TOLERANCES (UNLESS SPECIFIED)	DIMENSION STYLE MM ONLY	SCALE 5:1	DESIGN UNITS METRIC	THIRD ANGLE PROJECTION
		4 PLACES ± --- ± --- 3 PLACES ± --- ± .004 2 PLACES ± 0.10 ± --- 1 PLACE ± --- ± --- ANGULAR ± 1/2°	DRAWN BY KS DATE 1987/09/11	CHECKED BY DATE	APPROVED BY DATE	C-GRID III DUAL ROW RIGHT ANGLE SHROUDED HEADER MOLEX INCORPORATED
DRAFT WHERE APPLICABLE MUST REMAIN WITHIN DIMENSIONS		MATERIAL NO. SEE CHART	DOCUMENT NO. SDA-90130	SHEET NO. 3 OF 4		

NO OF CKTS	HSG CKT SIZE	PART NUMBER		
		PLATING TYPE A	PLATING TYPE E	PLATING TYPE F
6	6	90130-X106	90130-X206	90130-X306
8	8	X108	X208	X308
10	10	X110	X210	X310
12	12	X112	X212	X312
14	14	X114	X214	X314
16	16	X116	X216	X316
18	18	X118	X218	X318
20	20	X120	X220	X320
22	22	X122	X222	X322
24	24	X124	X224	X324
26	26	X126	X226	X326
28	28	X128	X228	X328
30	30	X130	X230	X330
32	32	X132	X232	X332
34	34	X134	X234	X334
36	36	X136	X236	X336
38	38	X138	X238	X338
40	40	X140	X240	X340
42	42	X142	X242	X342
44	44	X144	X244	X344
46	46	X146	X246	X346
48	48	X148	X248	X348
50	50	X150	X250	X350
52	52	X152	X252	X352
54	54	X154	X254	X354
56	56	X156	X256	X356
58	58	X158	X258	X358
60	60	X160	X260	X360
62	62	X162	X262	X362
64	64	X164	X264	X364
66	66	X166	X266	X366
68	68	90130-X168	90130-X268	90130-X368

NOTES:

1. FOR ASSY SEE SHEET 3.
2. FOR PLATING DETAILS SEE SDES-99000-0003

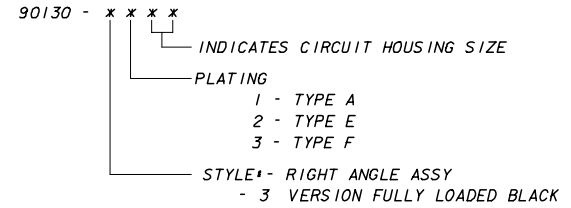

VERSION FULLY LOADED

REMOVED NATURAL OPT EC NO: E2008-0083 DRAWN BY: DRW:NDIBYRNES 2007/06/28 CHKD: CHFKO: 2007/09/06 APPR: EOMAHONY 2007/09/07	QUALITY SYMBOLS	GENERAL TOLERANCES (UNLESS SPECIFIED)	DIMENSION STYLE	SCALE	DESIGN UNITS	THIRD ANGLE PROJECTION	
	▽=0 ▽=0	mm INCH	MM ONLY	---	METRIC		
		4 PLACES ± --- ± --- 3 PLACES ± --- ± --- 2 PLACES ± --- ± --- 1 PLACE ± --- ± ---	DRAWN BY: KS DATE: 1987/09/10 CHECKED BY: DATE: APPROVED BY: DATE:	TITLE: C-GRID III DUAL ROW RIGHT ANGLE SHROUDED HEADER			
		ANGULAR ± --- °	MATERIAL NO. DOCUMENT NO. SHEET NO.	MOLEX INCORPORATED SDA-90130 4 OF 4			
		DRAFT WHERE APPLICABLE MUST REMAIN WITHIN DIMENSIONS	SEE CHART THIS DRAWING CONTAINS INFORMATION THAT IS PROPRIETARY TO MOLEX INCORPORATED AND SHOULD NOT BE USED WITHOUT WRITTEN PERMISSION				