

# Mini-Com® TX6™ PLUS Shielded Jack Modules

## specifications

Category 6/Class E, 8-position, shielded jack module shall terminate 4-pair, 22 – 26 AWG, 100 ohm shielded twisted pair cable and shall not require use of a punchdown tool. Shielded jack modules shall use a forward motion termination method to optimize performance by maintaining cable pair geometry while eliminating conductor untwist. The termination cap shall be color-coded white to designate Category 6 performance and shall include a universal label coded for T568A and T568B wiring schemes.



## technical information

<b>Category 6/Class E channel and component performance:</b>	Exceeds channel requirements of ANSI/TIA-568-C.2 Category 6 and ISO 11801 Class E standards at swept frequencies 1 to 250 MHz Exceeds component requirements of ANSI/TIA-568-C.2 Category 6 and ISO 11801 Class E standards at swept frequencies 1 to 250 MHz
<b>FCC and ANSI compliance:</b>	Meets all applicable ANSI/TIA-968-A requirements; contacts plated with 50 microinches of gold for superior performance
<b>IEC compliance:</b>	Meets IEC 60603-7
<b>PoE compliance:</b>	Meet requirements of IEEE 802.af and IEEE 802.3at for PoE applications
<b>UL rated:</b>	UL 1863 approved
<b>RoHS compliance:</b>	Compliant
<b>Conductor termination range:</b>	Wire cap compatible with 22 – 26 AWG solid or stranded cable with conductor insulation diameters of 0.060 in. max and overall cable O.D. 0.200 in. to 0.330 in.; marine jack module wire cap compatible with 22 AWG solid or stranded cable with 0.071 in. (1.80mm) maximum insulated conductor outside diameter cable

## key features and benefits

<b>100% performance tested</b>	Confidence that each jack module will deliver the critical electrical performance requirements
<b>Utilizes enhanced Giga-TX™ Technology</b>	Optimizes performance by eliminating conductor untwist and reduces installation time and expense
<b>Improved termination cap</b>	Conductor retention slots simplify jack module termination
<b>Integral shield</b>	Provides a 360° conductive path to ground shielded jack module with no additional assembly required; shield provides seamless bonding of the jack module with Mini-Com® All Metal Modular Patch Panels
<b>Modular</b>	Shielded jack modules snap in and out of all Mini-Com® Faceplates, Metal Modular Patch Panels, and Surface Mount Boxes for easy moves, adds, and changes
<b>True strain relief</b>	Controls cable bend radius for long term installed performance
<b>Individually serialized</b>	Marked with quality control number for future traceability
<b>RJ45 interface</b>	Industry standard interface provides a quick and easy plug and play connection to RJ45 patch cords; backwards compatible
<b>Identification</b>	Can be clearly identified with optional labels and icons for port identification
<b>Keyed version available</b>	Color-specific keys with positive and negative keying features mechanically and visually distinguish connections to prevent unintentional mating with unlike keyed or non-keyed modular plugs, offering network design flexibility, versatility, accommodating discrete networks for enhanced security
<b>Marine compatible version available</b>	Terminates to TX6000™ Shielded S/FTP Marine Copper Cable, which includes a durable flame-, oil-, UV- and MUD-resistant cable jacket; ideal for use in harsh environments encountered in marine applications including ship and offshore/ onshore units
<b>Termination tools (optional)</b>	EGJT termination tool ensures conductors are fully terminated by utilizing a smooth forward motion without impact on critical internal components for maximum reliability; TGJT termination tool ideal for high volume installations
<b>Block out device (optional)</b>	Provides a simple and secure method to control access to data ports while not in use

## applications

Mini-Com® TX6™ PLUS Shielded Jack Modules are a component of the TX6000™ Shielded Copper Cabling System. This end-to-end system is interoperable and backwards compatible, providing design flexibility to protect network investments well into the future. With certified performance to the ANSI/TIA-568-C.2 Category 6 and ISO 11801 Class E standards, this system is ideal for today's high performance workstation applications. With certified performance to the

ANSI/TIA-568-C.2 Category 6 and ISO 11801 Class E Edition 2.1 standards, these systems will support the following applications:

- Ethernet 10BASE-T, 100BASE-T (Fast Ethernet), 1000BASE-T (Gigabit Ethernet)
- 155 Mb/s ATM, 622 Mb/s ATM, 1.2 Gb/s ATM
- Token Ring 4/16
- Digital video and broadband/baseband analog video
- Voice over Internet Protocol (VoIP)

### TX6™ PLUS Shielded Copper Cabling System

#### Mini-Com® TX6™ PLUS Shielded Jack Modules

<b>Jack module:</b>	CJS688TG*Y
<b>Keyed jack module:</b>	CJSK688TG**
<b>Marine jack module:</b>	CJSM688TG+

#### TX6™ Shielded Copper Cable

<b>CM, F/UTP:</b>	PFC6004***-KD
<b>LSZH, F/UTP:</b>	PFL6004+-KD
<b>LSZH, SF/UTP:</b>	PSFL6004+-KD

#### TX6000™ Shielded S/FTP Marine Copper Cable

<b>LSZH:</b>	PSM6004BU**+LED
--------------	-----------------

#### TX6A™ 10Gig™ Shielded CM/LSZH Patch Cords

<b>Foot lengths:</b>	STP6X*IG
<b>Meter lengths:</b>	STP6X*MIG

#### Mini-Com® Angled All Metal Modular Patch Panels

<b>24-port, 1 RU:</b>	CPA24BLY
<b>48-port, 2 RU:</b>	CPA48BLY
<b>72-port, 2 RU:</b>	CPA72BLY

#### Mini-Com® Flat All Metal Modular Patch Panels

<b>24-port, 1 RU:</b>	CP24BLY
<b>48-port, 2 RU:</b>	CP48BLY
<b>72-port, 2 RU:</b>	CP72BLY

#### Tools and Accessories

<b>Jack module termination tool:</b>	EGJT or TGJT
<b>Wire snipping tool:</b>	CWST
<b>Wire stripping tool:</b>	CJAST
<b>Clear dust cap:</b>	MDC-C
<b>Block out device:</b>	PSL-DCJB-***
<b>Phone icons:</b>	CIDIW-C+
<b>Data icons:</b>	CIDIW-C+

\*To designate color, add BU (Blue), RD (Red), YL (Yellow), GR (Green) or VL (Violet). For part number CJS688TGY (no designation), the color is black.

\*\*To designate color, add suffix BL (Black), BU (Blue), RD (Red), YL (Yellow), GR (Green) or OR (Orange). Each color representing a different keyed configuration.

†Offered in black only.

\*\*\*To designate color, add suffix IG (International Gray) or LG (Light Gray).

\*To designate color, add suffix WH (White) or DG (Dark Gray).

\*\*To designate color, add suffix BL (Black) or IG (International Gray). For other cable colors, contact customer service.

†For lengths 3 to 20 feet (one foot increments) and 25, 30, 35, 40 feet, change the length designation in the part number to the desired length. For standard cable colors other than IG (International Gray), substitute the IG suffix with BL (Black), BU (Blue), RD (Red), YL (Yellow), GR (Green), OR (Orange) or VL (Violet). For example, the part number for a blue 15-foot patch cord is STP6X15BU.

\*\*For lengths 1 to 10 meters (one meter increments) and 1.5, 2.5, 15, 20 meters, change the length designation in the part number to the desired length. For standard cable colors other than IG (International Gray), substitute the IG suffix with BL (Black), BU (Blue), RD (Red), YL (Yellow), GR (Green), OR (Orange) or VL (Violet). For example, the part number for a blue 15-meter patch cord is STP6X15MBU.

\*\*\*To designate color other than Red, add suffix BL (Black), BU (Blue), YL (Yellow), GR (Green), OR (Orange), IW (Off White) or IG (International Gray) at the end of the part number. 10/package.

Contact customer service for bulk packaged and/or keyed jack modules and patch cords. Panduit recommends installing shielded jack modules in Mini-Com® All Metal Modular Patch Panels. For grounding shielded jack modules not installed in a Mini-Com® All Metal Modular Patch Panel, use the shielded jack module grounding kit, part number CJSK-XY.

# Mini-Com® TX6™ PLUS Shielded Jack Modules

## Test Results

Mechanical Test	Test Method	Measurement	Typical Test Results
Normal Force	—	Load (grams)	> 100
Vibration	IEC 512-6d	Circuit Resistance (mOhms)	< 40
Shock	IEC 512-6c	Contact Disturbance (microsecond)	< 5
Durability	IEC 512-9a	Circuit Resistance (mOhms)	< 40
Mating/Un-mating	IEC 512-13b	Mating Force (N)	< 20
		Un-mating Force (N)	< 20

Electrical Test	Test Method	Measurement	Typical Test Results
Low Level Circuit Resistance	IEC 512-2a	Resistance (mOhms)	< 20
Dielectric Withstand Voltage	IEC 512-4a	1000 V, 1 minute	Passed
Insulation Resistance	IEC 512-3a	Resistance (MOhms)	> 500

Environmental Test	Test Method	Measurement	Typical Test Results
Temperature Life	IEC 512-9b	Circuit Resistance (mOhms)	< 40
Humidity	IEC 512-11c	Circuit Resistance (mOhms)	< 40
Thermal Shock	IEC 512-11d	Circuit Resistance (mOhms)	< 40
Climatic Sequence	IEC 512-11a	Circuit Resistance (mOhms)	< 40
Flowing Mixed Gas Corrosion	IEC 512-11g	Circuit Resistance (mOhms)	< 40

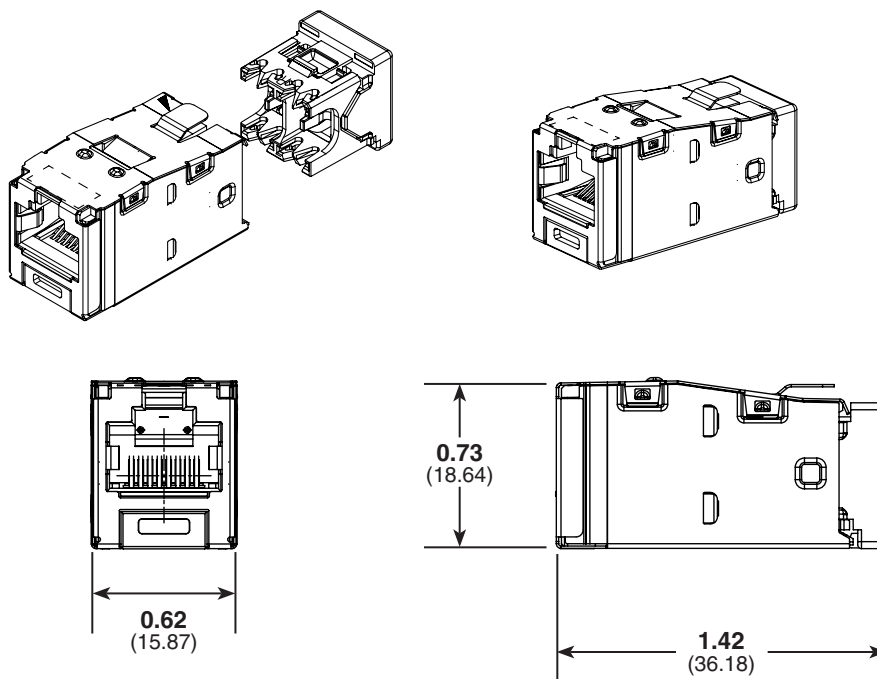

Dimensions are in inches (Dimensions in parenthesis are metric)

### WORLDWIDE SUBSIDIARIES AND SALES OFFICES

PANDUIT CANADA  
Markham, Ontario  
cs-cdn@panduit.com  
Phone: 800.777.3300

PANDUIT EUROPE LTD.  
London, UK  
cs-emea@panduit.com  
Phone: 44.20.8601.7200

PANDUIT SINGAPORE PTE. LTD.  
Republic of Singapore  
cs-ap@panduit.com  
Phone: 65.6305.7575

PANDUIT JAPAN  
Tokyo, Japan  
cs-japan@panduit.com  
Phone: 81.3.6863.6000

PANDUIT LATIN AMERICA  
Guadalajara, Mexico  
cs-la@panduit.com  
Phone: 52.33.3777.6000

PANDUIT AUSTRALIA PTY. LTD.  
Victoria, Australia  
cs-aus@panduit.com  
Phone: 61.3.9794.9020

For a copy of Panduit product warranties, log on to [www.panduit.com/warranty](http://www.panduit.com/warranty)

For more information

Visit us at [www.panduit.com](http://www.panduit.com)

Contact Customer Service by email: [cs@panduit.com](mailto:cs@panduit.com)  
or by phone: 800.777.3300

**PANDUIT®**

©2015 Panduit Corp.  
ALL RIGHTS RESERVED.  
**COSP315--WW-ENG**  
Replaces WW-COSP35  
3/2015