

THIS COPY IS PROVIDED ON A RESTRICTED BASIS AND IS NOT TO BE USED IN ANY WAY DETRIMENTAL TO THE INTERESTS OF PANDUIT CORP.

PANDUIT PART NUMBER	ALUMINUM CONDUCTOR SIZE	STUD SIZE	OVERALL LENGTH "A" +/- .12	BARREL LENGTH "B" MIN	BARREL		TONGUE WIDTH "W" +/- .060	TONGUE THICKNESS "T" +/- .04	TONGUE LENGTH "P" MIN	HOLE OFFSET "G" +/- .06	WRENCH CLEARANCE "C" REF	WIRE STRIP LENGTH	PANDUIT CRIMP TOOL PART NUMBERS	
					I.D. +/- .02	O.D. +/- .06							CT-2940, CT-940CH	
					DIE PART NO./DIE SET COLOR & INDEX NO./ NUMBER OF CRIMPS									
LAA900-58-1	900 kcmil	5/8"	6.63	3.38	1.13	1.66	1.74	0.59	1.88	0.88	1.00	3-7/16"	CD-940-800A* GRAY P140 4 CRIMPS	

\*CD-940 DIES TO BE USED EXCLUSIVELY WITH CT-940CH AND CT-2940 TOOLS

NOTES:

1. MATERIAL: SEAMLESS ALUMINUM TUBING
2. TIN PLATED
3. BARREL COLOR CODED WITH DIE SET INDEX NUMBER
4. UL LISTED & TEMPERATURE RATED 90°C (AL9)
5. CSA CERTIFIED
6. FOR STRANDED ALUMINUM WIRE ONLY
7. ALL DIMENSIONS IN INCHES

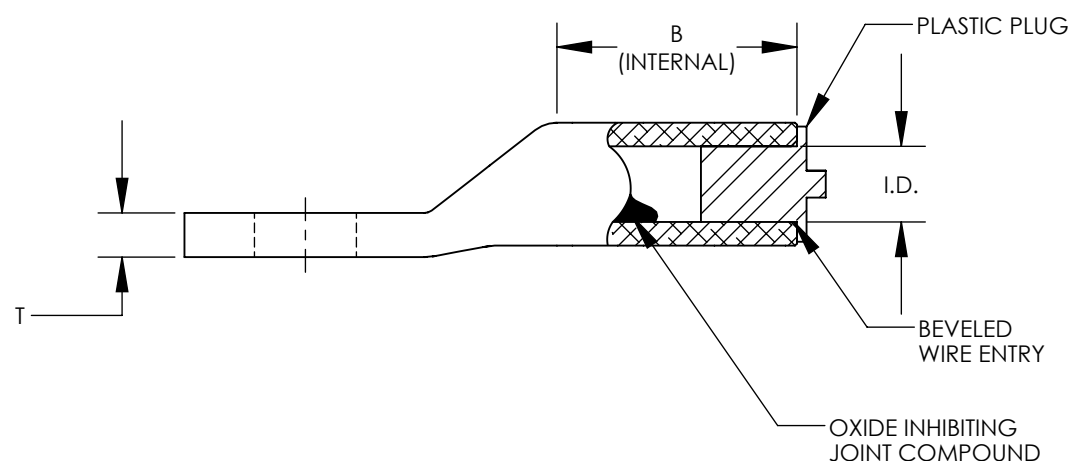
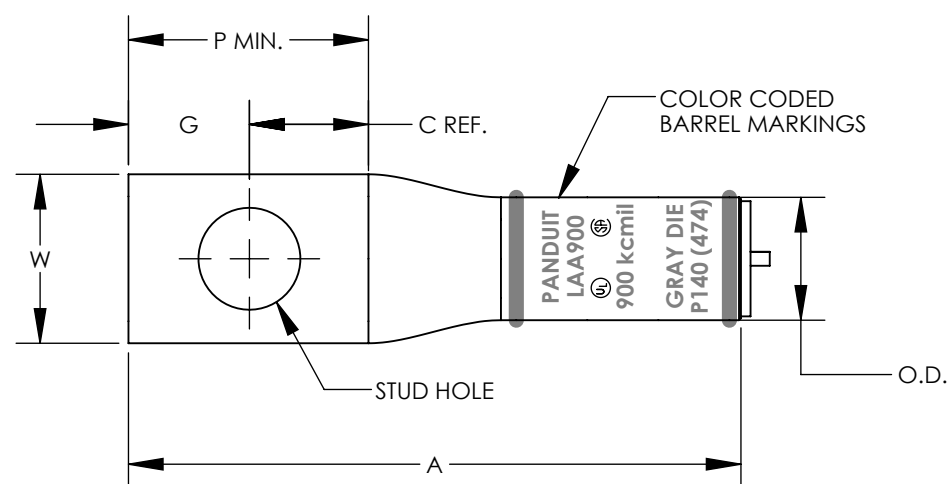

REV	DATE	BY	CHK	APR	DESCRIPTION	ECN
00	7/14	JHNU	JHNU	RGB	DRAWING RELEASED	12J037BF-DC

TITLE <b>LAA SERIES 900kcmil ALUMINUM LUG CUSTOMER DRAWING</b>	
ITEM REVISION NAME 12J037BF/00	<b>PANDUIT</b>
DATASET FILE NAME 12J037BF-DC/00.SLDDRW	
UNLESS OTHERWISE SPECIFIED, DIMENSIONAL TOLERANCES ARE: IN [mm] .X ± .XXX ± .XX ± ANGLES ±	
THIRD ANGLE PROJECTION	MATERIAL SEE NOTES
DRAWING NUMBER 12J037BF-DC	SIZE B
DRAWN BY JHNU	DATE 7/14
CHK RGB	SCALE NONE
SHEET 1 OF 1	