

THIS COPY IS PROVIDED ON A RESTRICTED BASIS AND IS NOT TO BE USED IN ANY WAY DETRIMENTAL TO THE INTERESTS OF PANDUIT CORP.

PANDUIT PART NUMBER	STUD SIZE	DIMENSIONS in.				
		A $\pm .03$	W $\pm .01$	C min	M $\pm .03$	H $\pm .01$
PN18-6FF	#6	.81 (20.57)	.28 (7.11)	.20 (5.08)	.65 (16.51)	.15 (3.81)
PN18-8FF	#8	.88 (22.35)	.31 (7.87)	.23 (5.84)	.66 (16.76)	.17 (4.32)
PN18-10FF	#10	.86 (21.84)	.35 (8.89)	.23 (5.84)	.66 (16.76)	.20 (5.08)

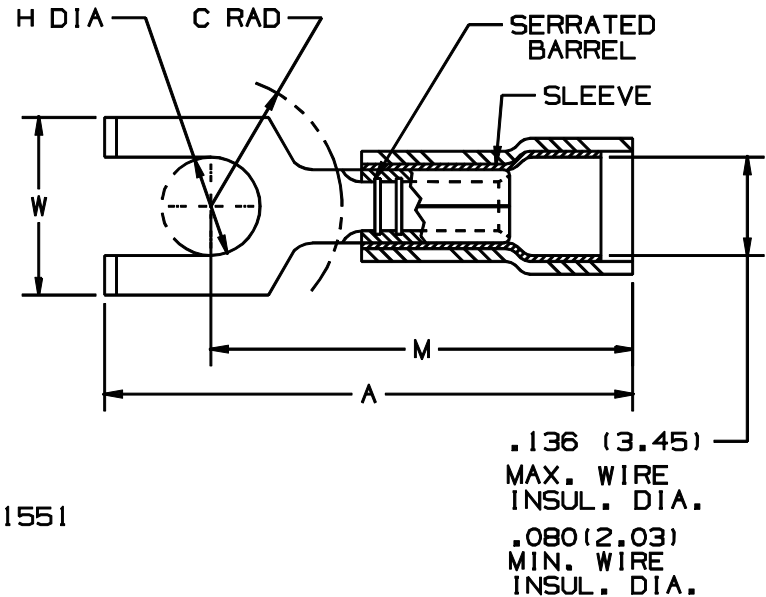

NOTES:

- UL LISTED AND CSA CERTIFIED FOR:
 - 600V. MAX. BLDG WIRE (1000 V. MAX IN SIGNS, FIXTURES & LUMINARIES)
 - #22-16 AWG SOLID OR STRANDED COPPER WIRE WITH THE CT-550, CT-500, CT1550, CT-1551 AND CT-400 (UL ONLY) INSTALLATION TOOLS.
 - #22-18 AWG SOLID OR STRANDED COPPER WIRE WITH THE CT-100 AND CT-250 INSTALLATION TOOLS.
 - 221°F (105°C) MAX TEMP. RATING
- MATERIAL:
 - STAMPING - .032" (.81) THK COPPER, TIN PLATED
 - HOUSING - NYLON, RED
 - SLEEVE - BRASS, TIN PLATED
- STRIP LENGTH - 7/32 $\pm 1/32_0$
- PACKAGE QTY:
 - C=100
 - M=1000
- DIMENSIONS IN BRACKETS ARE IN MILLIMETERS

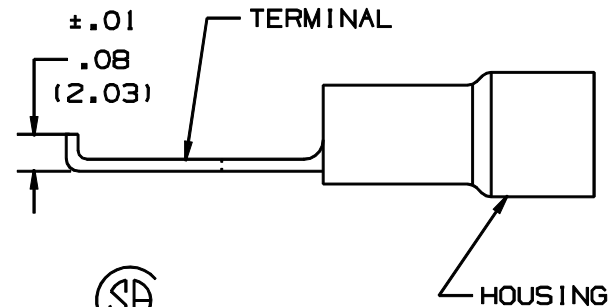

LISTED
587H
E52164



CERTIFIED
LR31212

A41239_06

PANDUIT

CORP.

TINLEY PARK, ILLINOIS

REV	DATE	BY	CHK	DESCRIPTION	ECN #	CUST	PM
06	1/01	KMD		CAD FILE SPEC. WAS N41239AA_PCD_05			
05	12/96	JAMB		ADDED DIM., "MIN WIRE INSUL. DIA." UPDATED NOTES	05372		
04	10/94	TH	RLS	REVISED TOOL/WIRE NOTES, DIMENSIONS	02600	LA	KS

#22-18 BARREL NYLON INSULATED FLANGED FORK, .136" (3.45) MAX. WIRE INSUL. DIA.

DRAWN BY DAW	CHK'D RLS	SCALE NONE	DRAWING NO. A41239
-----------------	--------------	---------------	-----------------------