

Flange - PTFIX-F - 3274060

Please be informed that the data shown in this PDF Document is generated from our Online Catalog. Please find the complete data in the user's documentation. Our General Terms of Use for Downloads are valid (<http://phoenixcontact.com/download>)



Flange, with screw-on fixing, length: 28.6 mm, width: 8.6 mm, height: 21.7 mm, color: gray

Your advantages

- Easy marking options



Key Commercial Data

Packing unit	20 pc
Minimum order quantity	20 pc
GTIN	
GTIN	4055626394152

Technical data

General

Color	gray
Material	PA
Flammability rating according to UL 94	V0
Ambient temperature (operation)	-60 °C ... 85 °C
Ambient temperature (storage/transport)	-25 °C ... 55 °C (For a short time, not exceeding 24 h, -60 to +70 °C)
Permissible humidity (storage/transport)	30 % ... 70 %
Ambient temperature (assembly)	-5 °C ... 70 °C
Ambient temperature (actuation)	-5 °C ... 70 °C

Dimensions

Width	8.6 mm
Length	28.6 mm
Height	21.7 mm
Hole diameter	3.2 mm

Flange - PTFIX-F - 3274060

Technical data

Connection data

Tightening torque max	0.3 Nm
-----------------------	--------

Standards and Regulations

Flammability rating according to UL 94	V0
--	----

Environmental Product Compliance

China RoHS	Environmentally friendly use period: unlimited = EFUP-e
	No hazardous substances above threshold values

Drawings

Dimensional drawing

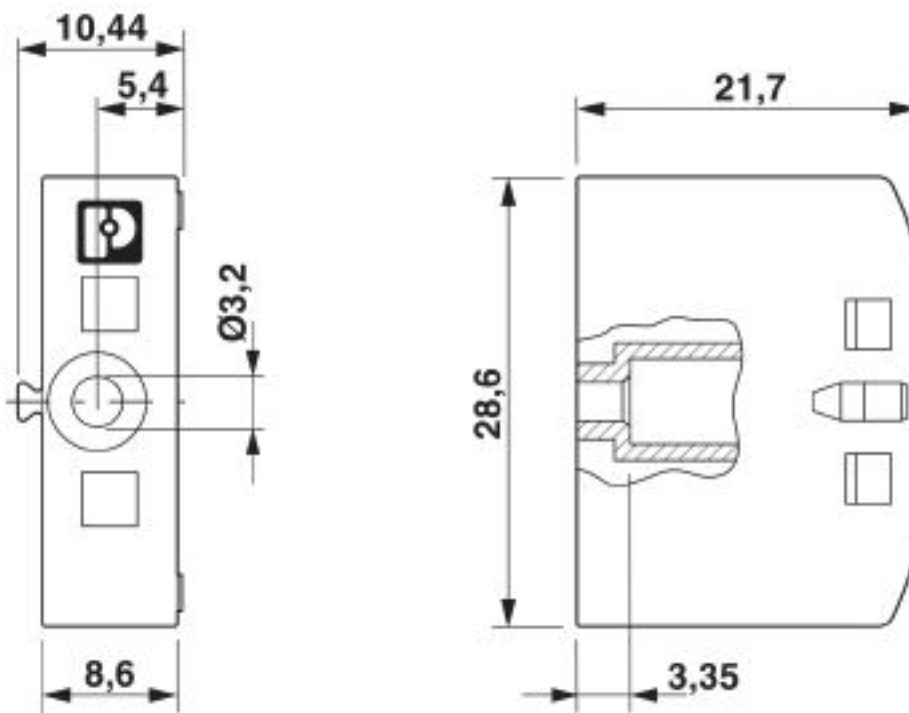

Classifications

eCl@ss

eCl@ss 10.0.1	27141190
eCl@ss 4.0	27141100
eCl@ss 4.1	27141100
eCl@ss 5.0	27141100
eCl@ss 5.1	27141100
eCl@ss 6.0	27141100
eCl@ss 7.0	27141190

Flange - PTFIX-F - 3274060

Classifications

eCl@ss

eCl@ss 8.0	27370419
eCl@ss 9.0	27370419

ETIM

ETIM 2.0	EC001031
ETIM 3.0	EC001031
ETIM 4.0	EC001031
ETIM 5.0	EC001024
ETIM 6.0	EC001024
ETIM 7.0	EC001024

UNSPSC

UNSPSC 6.01	31261501
UNSPSC 7.0901	31261501
UNSPSC 11	31261501
UNSPSC 12.01	31261501
UNSPSC 13.2	31261501
UNSPSC 18.0	39121708
UNSPSC 19.0	39121708
UNSPSC 20.0	39121708
UNSPSC 21.0	39121708

Approvals

Approvals

Approvals

EAC

Ex Approvals

Approval details

EAC		RU C- DE.AI30.B.01102
-----	---	--------------------------

Phoenix Contact 2020 © - all rights reserved
<http://www.phoenixcontact.com>

PHOENIX CONTACT GmbH & Co. KG
Flachmarktstr. 8
32825 Blomberg
Germany
Tel. +49 5235 300
Fax +49 5235 3 41200
<http://www.phoenixcontact.com>