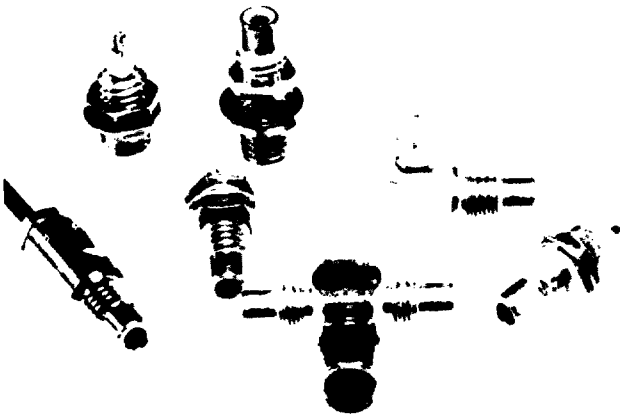

50 Ω

DC – 10 GHz

**GENERAL**

- Subminiature coaxial connectors
- Screw-on coupling
- Low weight
- Reduced outline dimensions

APPLICABLE STANDARDS

- MIL-C-39012

APPLICATIONS

- IF Systems
- Civil & Military Telecommunication
- Aeronautics
- Missiles
- Edge mounting applications

VI**CONTENTS**

General	VI 3
Characteristics	VI 4
Interface	VI 5
Plugs & Jacks	VI 6-8
Torque wrench	VI 8
Receptacles	VI 9-10
In series adapters	VI 11
Mounting instructions	VI 12-17

REQUIREMENT	MIL - C - 39012 paragraph	GENERAL SPECIFICATIONS	
ELECTRICAL			
Impedance		50 Ω	
Frequency range		0 - 10 GHz	
V.S.W.R.	3 - 14	cable 2/50	2,6/50
		straight 1,25 + 0,04 F (GHz)	1,20 + 0,04 F (GHz)
		right angle 1,40 + 0,06 F (GHz)	1,30 + 0,04 F (GHz)
Insertion loss	3 - 27	straight : 0,25 dB max. at 4 GHz	
		right angle : 0,5 dB max. at 4 GHz	
		- 60 dB min. between 2 and 3 GHz	
RF leakage	3 - 26	1000 megohms min.	
Insulation resistance	3 - 11		
Contact resistance	3 - 16		
			Initial After environment
		Center contact (m Ω)	6 8
		Outer contact (m Ω)	1 1,5
Voltage rating (volts RMS)		cable 2/50 : at sea level 250 V, at 70000 ft	60 V
		cable 2,6/50 : at sea level 335 V, at 21000 m	85 V
Dielectric withstanding voltage	3 - 17	cable 2/50 : at sea level 750 V, at 70000 ft	185 V
		cable 2,6/50 : at sea level 1000 V, at 21000 m	250 V
RF high potential withstanding voltage (Frequency 5 MHz)	3 - 23	cable 2/50 : at sea level 500 V	
		cable 2,6/50 : at sea level 700 V	
MECHANICAL			
Life	3 - 15	500 matings	
Force to engage and disengage	3 - 5 - 1	torque : 16 inch-ounces max. - 11,3 Ncm	
Mating torque		35 to 50 inch-ounces - 25 to 35 Ncm	
Coupling nut proof torque		100 inch-ounces - 71 Ncm	
Coupling nut retention force	3 - 25	35 lbs. min. - 156 N min.	
Cable retention force	3 - 24	cable 2/50 : 13 lbs - 58 N and cable 2,6/50 : 25 lbs - 110 N	
Contact captivation		axial force : 4 lbs - 18 N. torque : not applicable.	
ENVIRONMENTAL			
Operating temperature range		standard models	: - 65°C + 165°C
		hermetic	: - 65°C + 165°C
		semi rigid cables	: - 65°C + 105°C
Temperature cycling		MIL - STD - 202, method 102, condition C	
Thermal shock	3 - 20	MIL - STD - 202, method 107, condition B	
High temperature test		MIL - STD - 202, method 108	
Corrosion (salt spray)	3 - 13	MIL - STD - 202, method 101, condition B, 5%	
Vibration	3 - 18	MIL - STD - 202, method 204, condition D, 20 g	
Shock	3 - 19	MIL - STD - 202, method 213, condition C, 100 g	
Moisture resistance	3 - 21	not applicable	
Barometric pressure	3 - 22	MIL - STD - 202, method 105, condition C	
Hermetic test		down to 10 ⁻⁶ mm Hg (Torr)	
		leak rate < 1 x 10 ⁻⁶ atm/cm ³ /sec	
MATERIALS			
Bodies and male contacts		brass, half hard per QQ - B - 626	
Female contacts and interfaces		beryllium copper per QQ - C - 530	
Ferrules		brass	
Insulators		PTFE teflon	
Gaskets		silicone rubber	
PLATING			
Body		gold to satisfy the corrosion requirements	
Center contacts		gold	

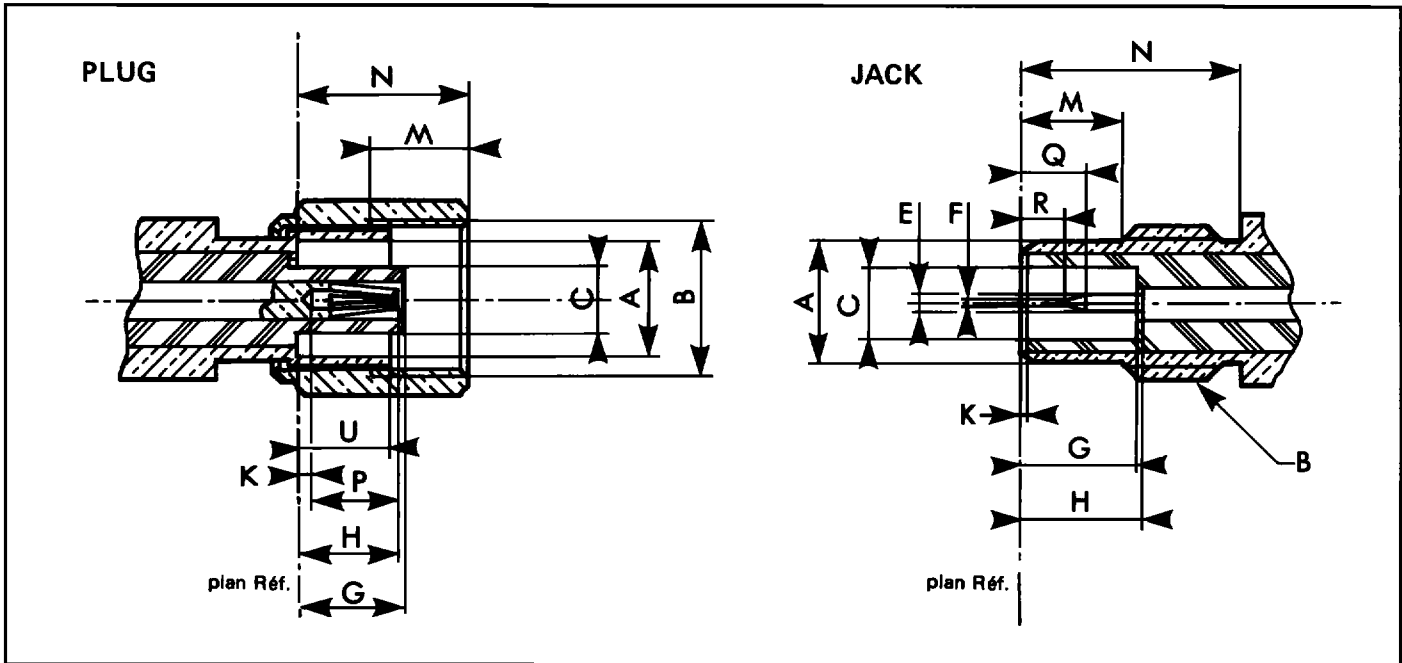

VI

SMC

Letter	PLUG				JACK			
	mm		Inch		mm		Inch	
	min.	max.	min.	max.	min.	max.	min.	max.
ØA	3,73	-	.147	-	-	3,71	-	.146
B	N° 10 - 32 UNF - 2 B				N° 10 - 32 UNF - 2 A			
ØC	-	2,06	-	.081	2,08	-	.082	-
ØE	-	-	-	-	0,48	0,53	.019	.021
ØF	-	-	-	-	-	0,25	-	.010
G	-	3,40	-	.134	3,40	-	.134	-
H	-	3,40	-	.134	3,40	-	.134	-
K	-	-	-	-	000	-	000	-
M	2,79	-	.110	-	3,12	3,38	.123	.133
N	-	5,92	-	.233	5,94	-	.234	-
P	2,79	-	.110	-	-	-	-	-
Q	-	-	-	-	-	2,13	-	.084
R	-	-	-	-	0,61	-	.024	-
U	-	3,10	-	.122	-	-	-	-

STRAIGHT PLUG

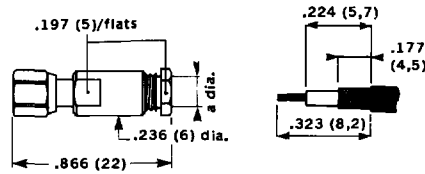
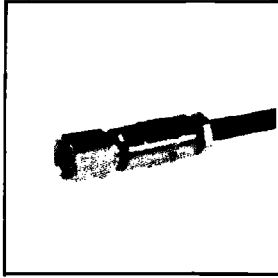

CABLE RG	178 B/U - 196 A/U	174 A/U - 188 A/U 179 B/U - 187 A/U
PART NUMBER	R 112 003	R 112 005
MIL no.	UG - 1460/U M39012/73-0003	UG - 1465/U M39012/73-0004
a dia.	.087 (2,2)	.118 (3)
Assembly	M 01	M 01

RIGHT ANGLE PLUG

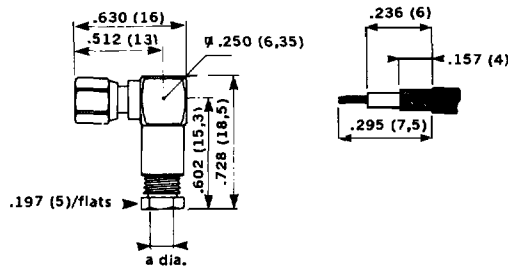
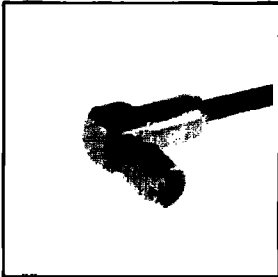

CABLE RG	178 B/U - 196 A/U	174 A/U - 188 A/U 179 B/U - 187 A/U
PART NUMBER	R 112 163	R 112 165
MIL no.	UG - 1461/U M39012/75-0003	UG - 1466/U M39012/75-0004
a dia.	.087 (2,2)	.118 (3)
Assembly	M 02	M 02

STRAIGHT JACK

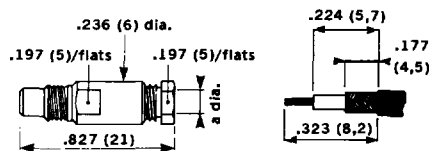
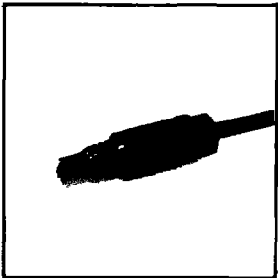

CABLE RG	178 B/U - 196 A/U	174 A/U - 188 A/U 179 B/U - 187 A/U
PART NUMBER	R 112 203	R 112 205
MIL no.	UG - 1462/U M39012/74-0003	UG - 1467/U M39012/74-0004
a dia.	.087 (2,2)	.118 (3)
Assembly	M 01	M 01

BULKHEAD JACK

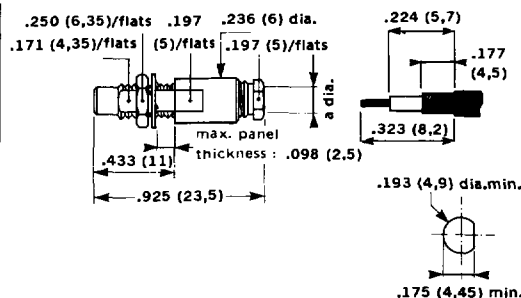
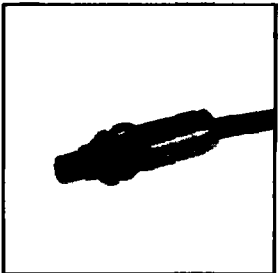

CABLE RG	178 B/U - 196 A/U	174 A/U - 188 A/U 179 B/U - 187 A/U
PART NUMBER	R 112 303	R 112 305
MIL no.	UG - 1463/U M39012/76-0003	UG - 1468/U M39012/76-0004
a dia.	.087 (2,2)	.118 (3)
Assembly	M 01	M 01

STRAIGHT PLUG

CABLE RG	178 B/U - 196 A/U	174 A/U - 188 A/U 179 B/U - 187 A/U
PART NUMBER	R 112 073	R 112 075
MIL no.	M 39012/73-0011	M 39012/73-0012
a dia.	.098 (2,5)	.126 (3,2)
Assembly	M 05	M 05

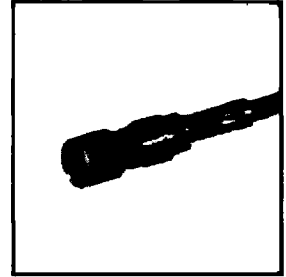
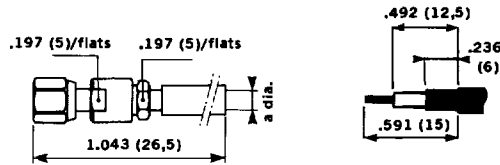

RIGHT ANGLE PLUG

CABLE RG	178 B/U - 196 A/U	174 A/U - 188 A/U 179 B/U - 187 A/U
PART NUMBER	R 112 183	R 112 186
MIL no.	M 39012/75-0011	M39012/75-0012
a dia.	.098 (2,5)	.126 (3,2)
Assembly	M 06	M 06

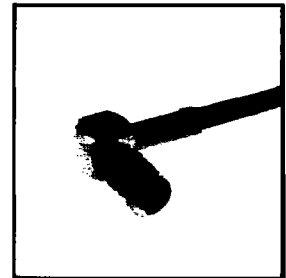
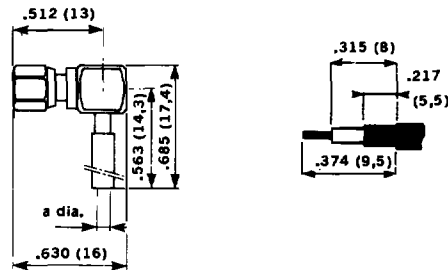

STRAIGHT JACK

CABLE RG	174 A/U - 188 A/U 179 B/U - 187 A/U
PART NUMBER	R 112 239
MIL no.	M39012/74-0012
Assembly	M 05

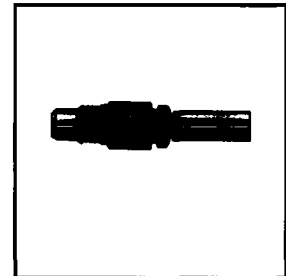
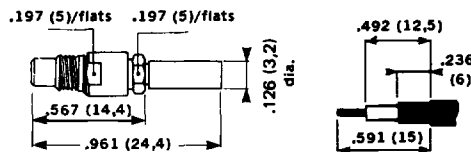

BULKHEAD JACK

CABLE RG	174 A/U - 188 A/U 179 B/U - 187 A/U
PART NUMBER	R 112 307
MIL no.	M 39012/76-0012
Assembly	M 05

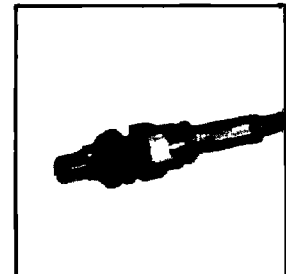
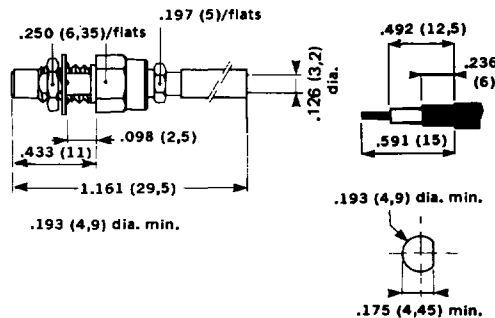

VI

STRAIGHT PLUG

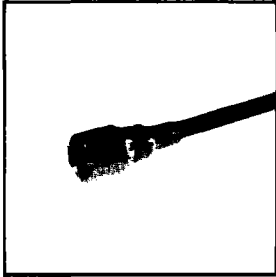

CABLE Ø	.085"
PART NUMBER	R 112 053
Assembly	M 03

RIGHT ANGLE PLUG

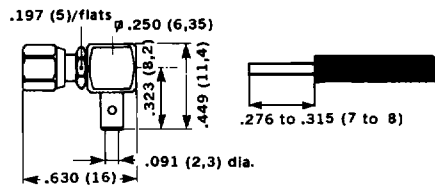
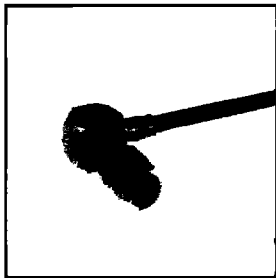

CABLE Ø	.085"
PART NUMBER	R 112 169
Assembly	M 04

TORQUE WRENCH : R 282 318

Torque : 35 to 50 inch-ounces - 25 to 35 Ncm.

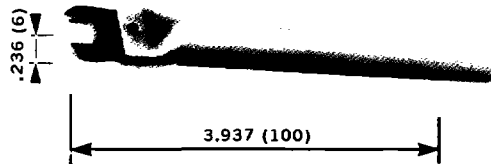

This torque wrench is preset to the recommended tightening torque and designed specifically for tightening the coupling nuts of plugs to the correct torque. Its use avoids damage to the interfaces and ensures good resistance to shock and vibration.

SQUARE FLANGE RECEPTACLE

PART NUMBER	R 112 403
-------------	-----------

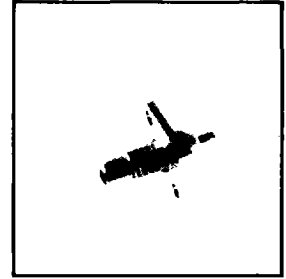
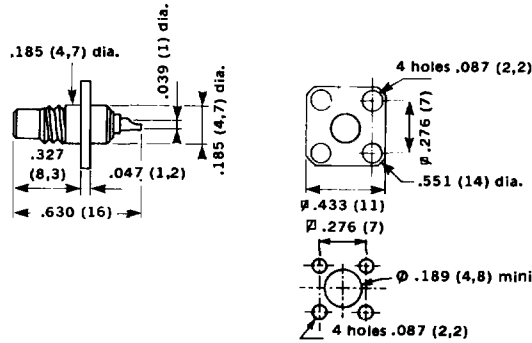

SQUARE FLANGE RECEPTACLE

PART NUMBER	R 112 413
Captive contact	NO + removable insulator

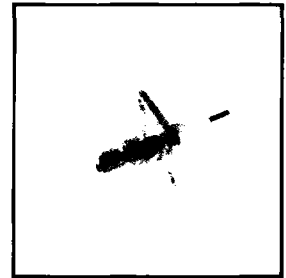
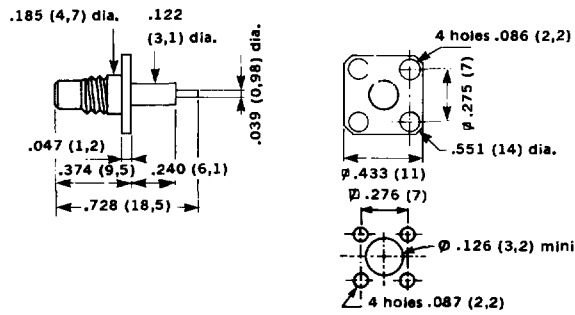

FRONT MOUNTING BULKHEAD RECEPTACLE

PART NUMBER	R 112 553
MIL no.	UG - 1464/U M39012/77-0002

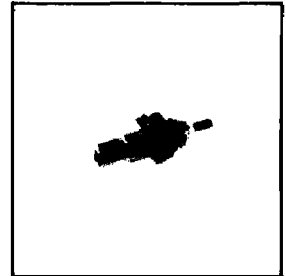
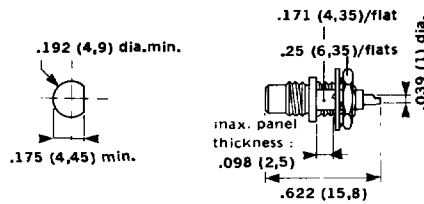

REAR MOUNTING BULKHEAD RECEPTACLE

PART NUMBER	R 112 554
MIL no.	UG - 1619/U M39012/77-0001

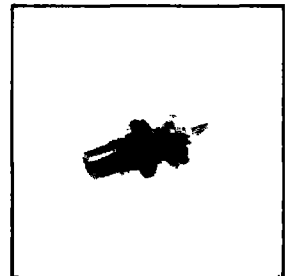
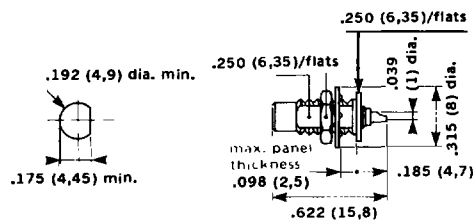

HERMETICALLY SEALED BULKHEAD RECEPTACLE REAR MOUNTING

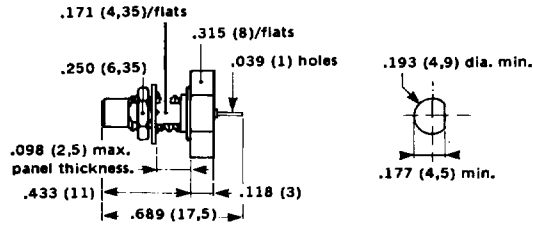
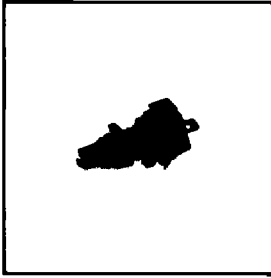

PART NUMBER

R 112 603

MIL no.

M39012/78-0001

RIGHT ANGLE BULKHEAD RECEPTACLE

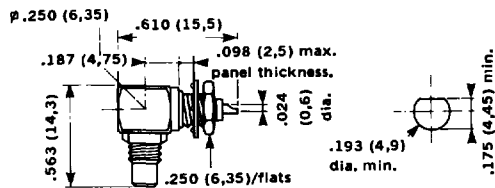
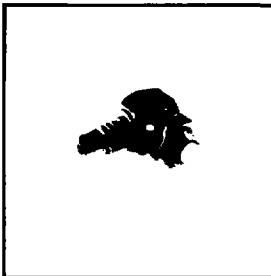

PART NUMBER

R 112 670

RECEPTACLES FOR PRINTED CIRCUIT BOARD MOUNTING

STRAIGHT PCB RECEPTACLE

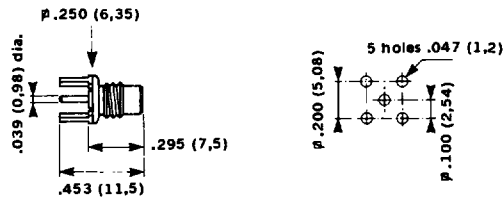
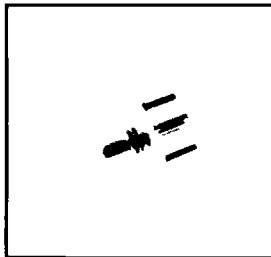

PART NUMBER

R 112 426

RIGHT ANGLE PCB RECEPTACLE

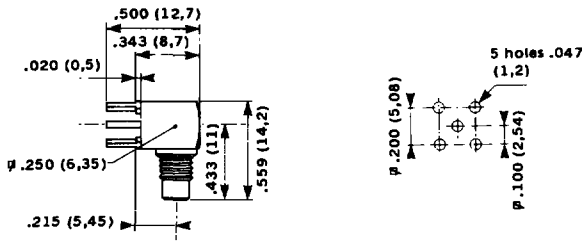
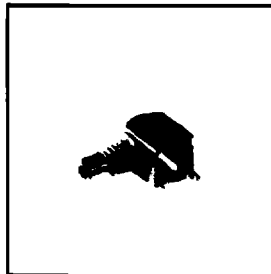

PART NUMBER

R 112 665

FEMALE - FEMALE (plug - plug)

PART NUMBER **R 112 704**

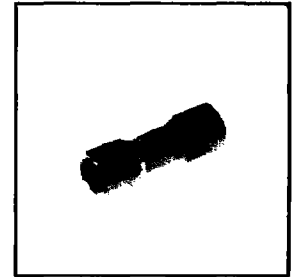
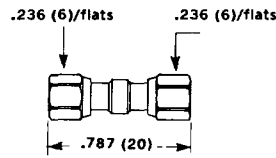

MALE - MALE BULKHEAD (jack - jack)

PART NUMBER **R 112 720**

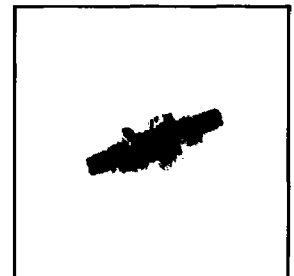
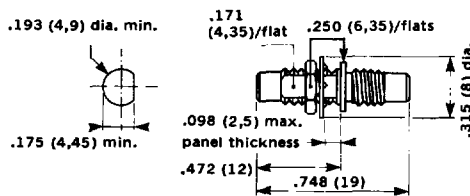

MALE - MALE HERMETICALLY SEALED BULKHEAD (jack - jack)

PART NUMBER **R 112 753**

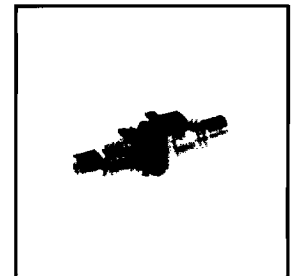
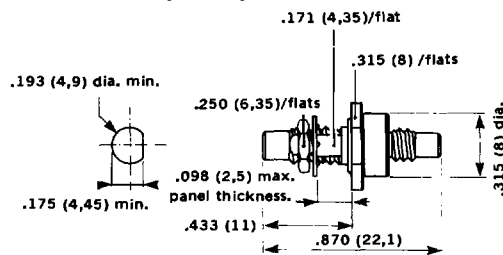

TEE MALE - MALE/FEMALE TEE MALE - MALE/MALE (jack - jack/plug) (jack - jack/jack)

PART NUMBER **R 112 780** fig. A
R 112 781 fig. B

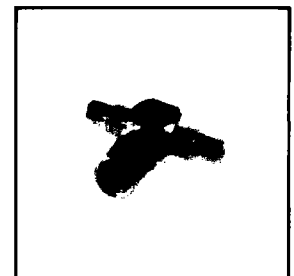
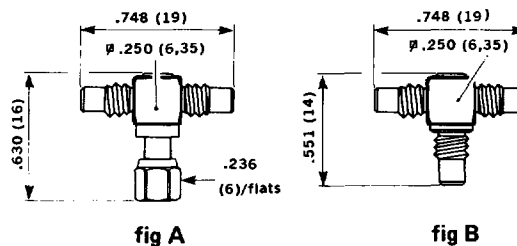

VI

MOUNTING INSTRUCTIONS

M 01

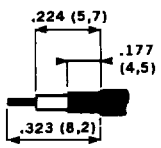
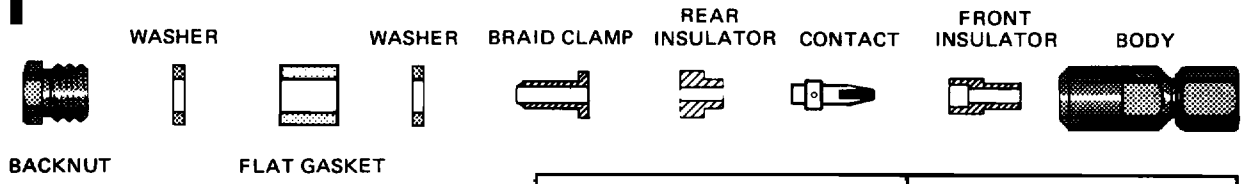

1

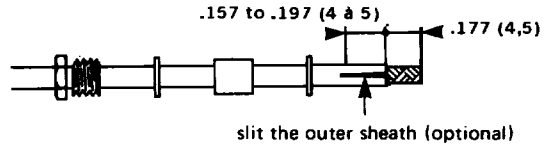

2

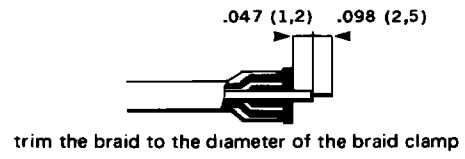

3

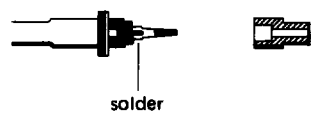

4



CONNECTORS	
R 112 003	In order to ensure good VSWR the plugs and jacks for 2,6/50 + 75 cables are supplied with 2 braid clamps : - for 2,6/50 cables use the knurled braid clamp. - for 2,6/75 cables use the smooth braid clamp.
R 112 005	
R 112 203	
R 112 205	
R 112 303	
R 112 305	

- 1 - 1 Slide the back nut, washer, gasket, washer over the cable.
- 1 - 2 Strip the cable.
- 1 - 3 Slit the sheath (optional) to ease positioning of the braid clamp under the braid.

- 2 - 1 Slide the braid clamp between the dielectric and the braid.
- 2 - 2 Trim the braid flush with the diameter of the braid clamp.
- 2 - 3 Cut the dielectric.

- 3 - 1 Fit the rear insulator.
- 3 - 2 Solder the contact.
- 3 - 3 Fit the front insulator over the contact.

- 4 - 1 Insert sub-assembly into the body.

MOUNTING INSTRUCTIONS

M 02

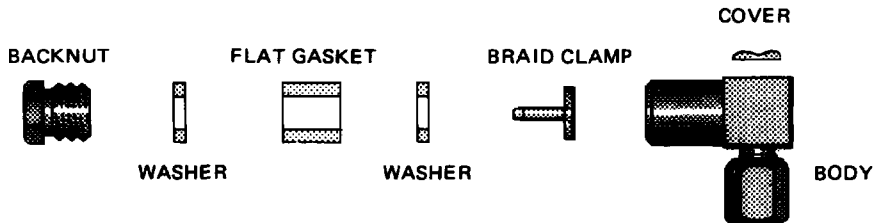

CONNECTORS	
R 112 163 R 112 165	<p>In order to ensure good VSWR the plugs and jacks for 2,6/50 + 75 cables are supplied with 2 braid clamps :</p> <ul style="list-style-type: none"> - for 2,6/50 cables use the knurled braid clamp. - for 2,6/75 cables use the smooth braid clamp.

- 1 - 1 Slide the back nut, washer, gasket, washer over the cable.
 1 - 2 Strip the cable.
 1 - 3 Slit the sheath (optional) to ease positioning of the braid clamp under the braid.

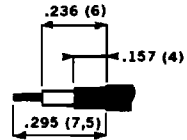

VI

1

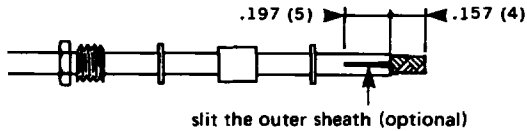

- 2 - 1 Slide the braid clamp between the dielectric and the braid.
 2 - 2 Trim the braid flush with the diameter of the braid clamp.
 2 - 3 Cut the dielectric.

2

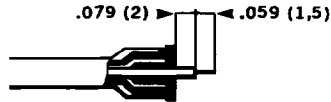

trim the braid to the diameter of the braid clamp

- 3 - 1 Fit the sub-assembly into the body.

3

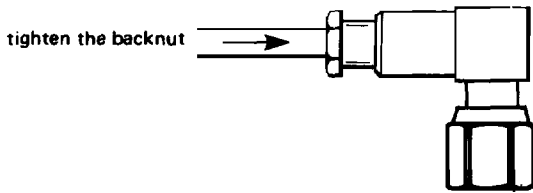

- 4 - 1 Solder the conductor in contact slot.
 4 - 2 Fit cover in housing as shown.

4

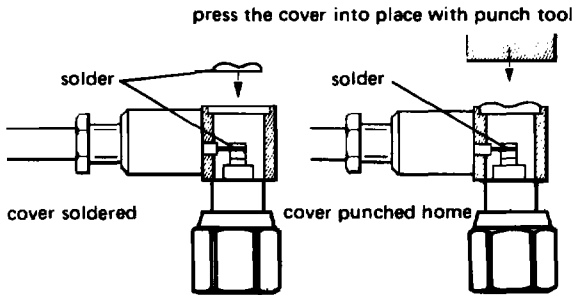

MOUNTING INSTRUCTIONS

M 03

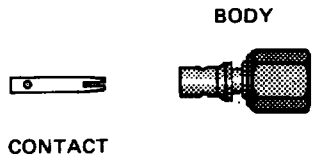

CONNECTOR
R 112 053

1

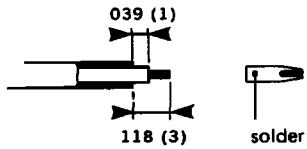

- 1 - 1 Cut the outer conductor and dielectric.
- 1 - 2 Solder the contact.

2

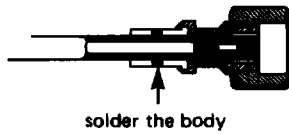

- 2 - 1 Fit the sub-assembly into the body.
- 2 - 2 Solder the body onto the semi-rigid

NOTE : In order to ensure correct positioning of the contact it is recommended that a receptacle is fitted to the plug prior to soldering the body.

MOUNTING INSTRUCTIONS

MAIN HOUSING



REAR INSULATOR

CONTACT



FRONT INSULATOR

FRONT BODY

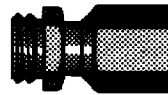

M 04

CONNECTOR

R 112 169

VI

1 - 1 Cut off the outer conductor.

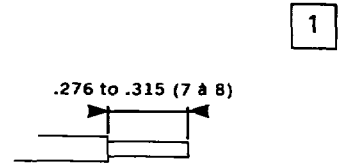

2 - 1 Push the cable through the main housing.
 2 - 2 Solder the body onto the semi-rigid.
 2 - 3 Cut back the dielectric.

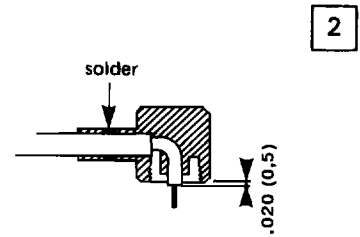

3 - 1 Fit the rear insulator.
 3 - 2 Solder the contact ensuring that the contact has been pushed home into the rear insulator.

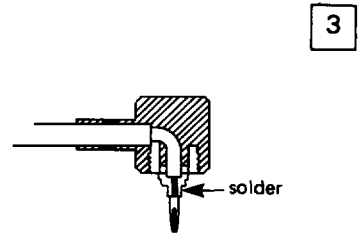

4 - 1 Fit the front insulator.
 4 - 2 Fit the front body onto the sub-assembly.

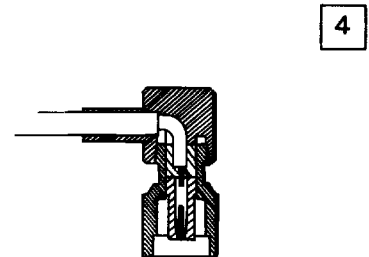

MOUNTING INSTRUCTIONS

M 05

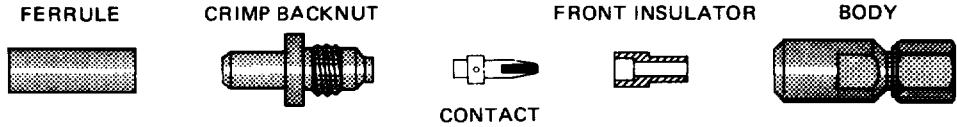

CONNECTORS	TOOLING
R 112 073 R 112 075 R 112 239 R 112 307	RADIALL crimp tool R 282 211 or RADIALL tool R 282 240 + RADIALL jaws R 282 241
	or BUCHANAN tool 612 648 + BUCHANAN jaws 612 784
	2 mm Ø cable : Hex. .105 (2,67) 2,6 mm Ø cable : Hex. .127 (3,25)

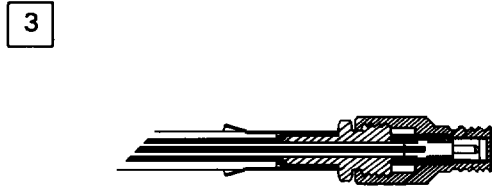
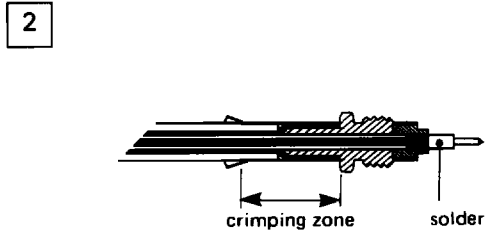
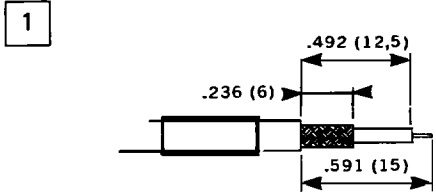

- 1 - 1 Slide the ferrule over the cable.
- 1 - 2 Strip the cable.
- 1 - 3 Open out the braid.

- 2 - 1 Slide the crimp backnut down between dielectric and braid.
- 2 - 2 Crimp the ferrule..
- 2 - 3 Solder the contact ensuring that the contact has been pushed has been pushed home into the rear insulator.

- 3 - 1 Fit the front insulator.
- 3 - 2 Insert sub-assembly into the body.

MOUNTING INSTRUCTIONS

M 06

CONNECTORS	TOOLING
R 112 183 R 112 186	RADIALL crimp tool R 282 211 or RADIALL tool R 282 240 + RADIALL jaws R 282 241
	or BUCHANAN tool 612 648 + BUCHANAN jaws 612 784
	2 mm Ø cable : Hex. .105 (2,67) 2,6 mm Ø cable : Hex. .127 (3,25)

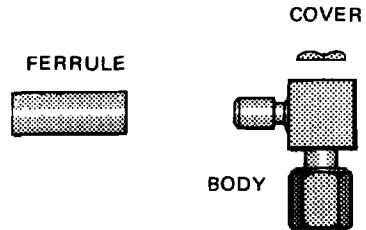

VI

- 1 - 1 Slide the ferrule over the cable.
- 1 - 2 Strip the cable.
- 1 - 3 Open out the braid

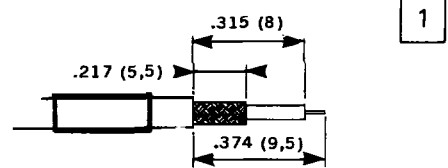

- 2 - 1 Slide the body down between dielectric and braid.
- 2 - 2 Crimp the ferrule.

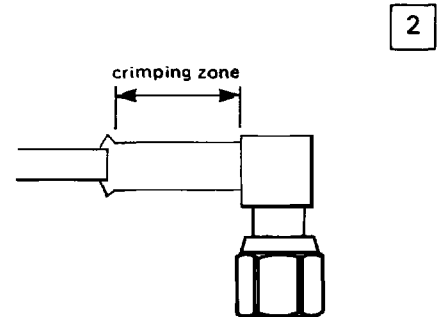

- 3 - 1 Solder the conductor in contact slot.
- 3 - 2 Fit cover in housing as shown.

