

**High current appliance inlet Type 4798**

Screw-on mounting from front  
Solder or quick-connect terminals  
Pin temperature 70 °C  
Protection class I

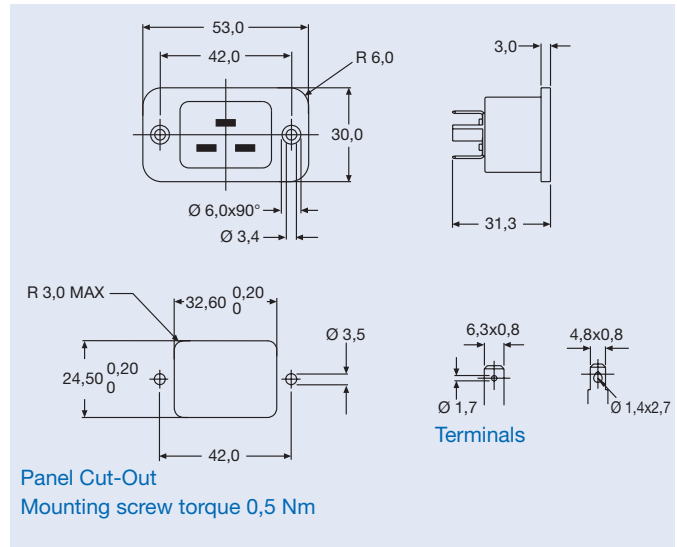
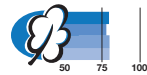

**High current appliance inlet Type 4793**

Snap-in mounting from front  
Solder or quick-connect terminals  
Pin temperature 70 °C  
Protection class I

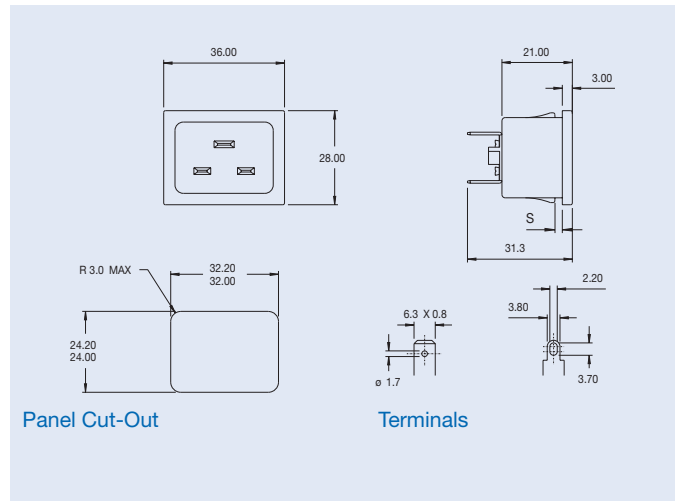
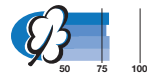

**Details Types 4798, 4793**

**Technical data**

- Rated current/voltage: 16 A/250 VAC
- Insulation resistance: > 10 MΩ (500 VDC, 1 Min.)
- Dielectric strength: 2 kV (50 Hz, 1 Min.), to accessible surfaces
- Material: Socket: Thermoplastic UL 94 V-0 black

**Standards**

IEC/EN 60320-1/C20  
UL 498, CSA 22,2

**Approvals: Inlet Type 4798**

- △ VDE (16 A / 250 VAC)
- UL (20 A / 250 VAC)
- CSA (22 A / 250 VAC)

**Approvals: Inlet Type 4793**

- △ VDE (16 A / 250 VAC)
- c UL/CSA (20 A / 250 VAC)

**Order Numbers**

Screw-on mounting		Snap-in mounting						Terminals
Type	4798	Type	4793					
		Panel thickness s						
		1,0 mm	1,2 mm	1,5 mm	2,0 mm	2,5 mm	3,0 mm	
4798.9000		4793.3000	4793.8000	4793.4000	4793.5000	4793.6000	4793.7000	Quick-connect terminals 6,3 x 0,8 mm
4798.9200		4793.3200	4793.8200	4793.4200	4793.5200	4793.6200	4793.7200	Solder terminals

Accessories see page 171