

REVISIONS				
ZONE	REV	DESCRIPTION	DATE	APPROVED

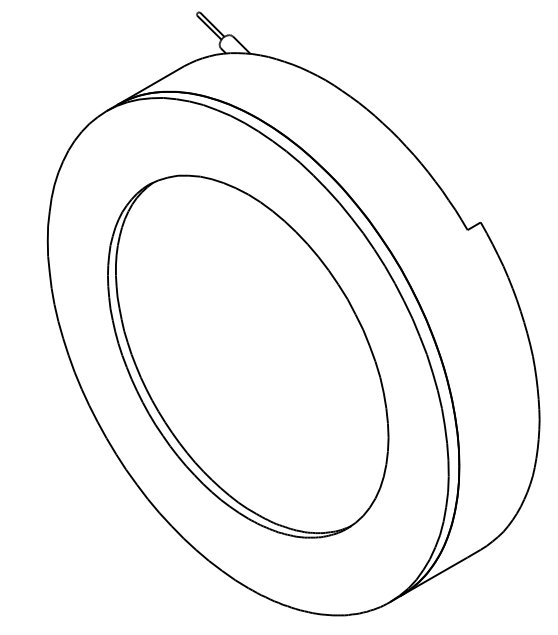

No.	Part Name	Material	Quantity
1	Wire (40mm)	UL1571 AWG32#	2
2	PCB	0.4 Tinned PCB	1
3	Frame	PBT	1
4	Magnet	NdFeB-N42	1
5	Plate	SPCC	1
6	Voice Coil	Copper	1
7	Membrane	PEN	1
8	Cap	SUS304	1
9	Screen Gasket	0.4 Single-sided cloth	1
10	Damping Net	180Mesh	1

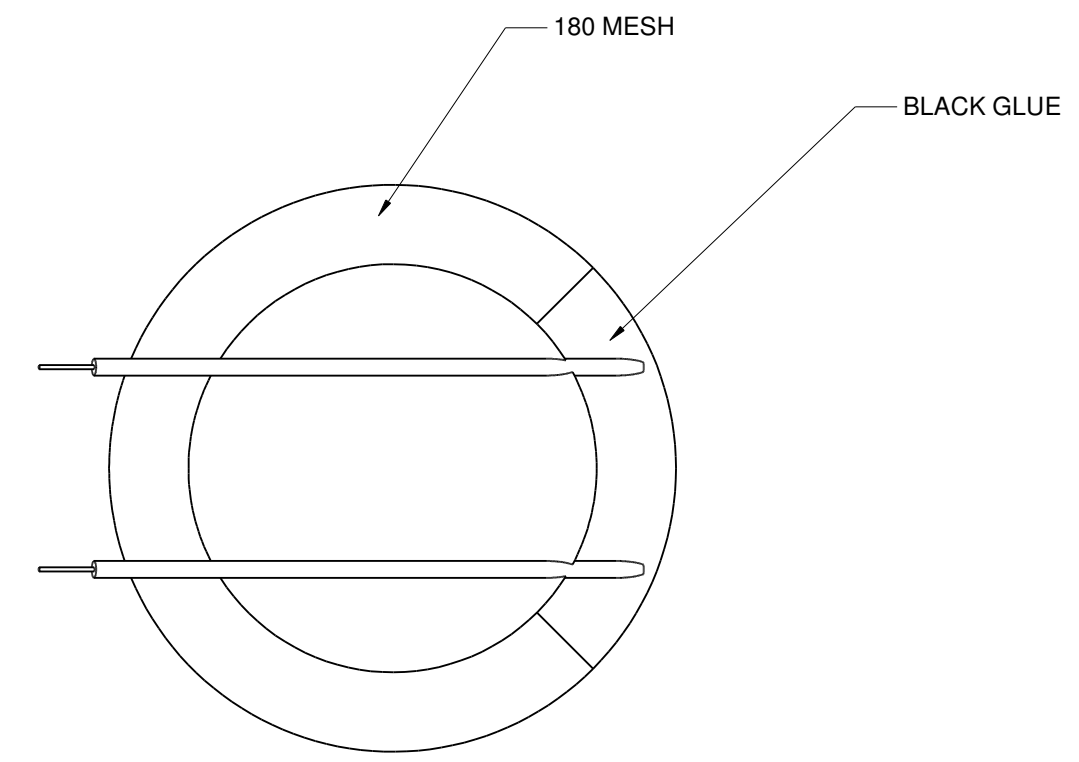
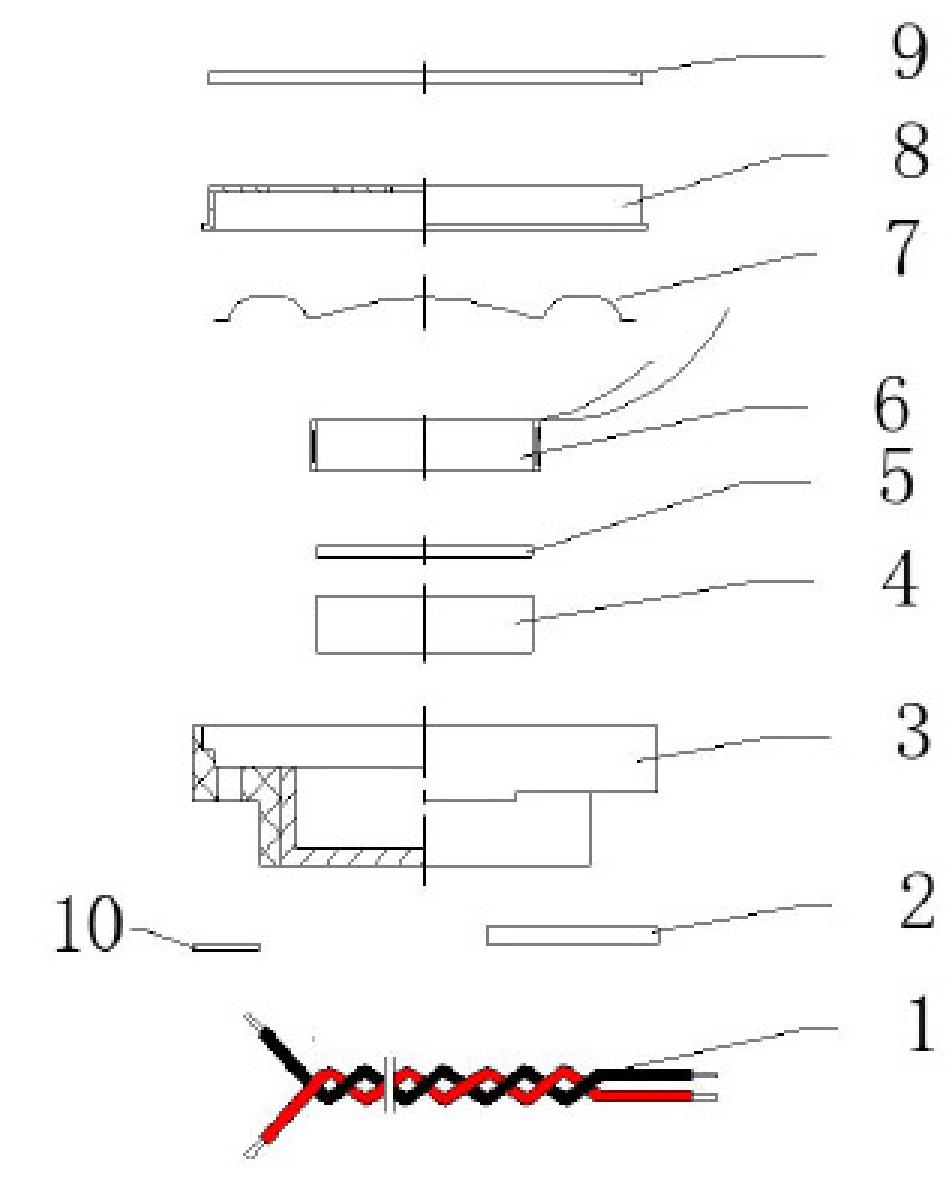
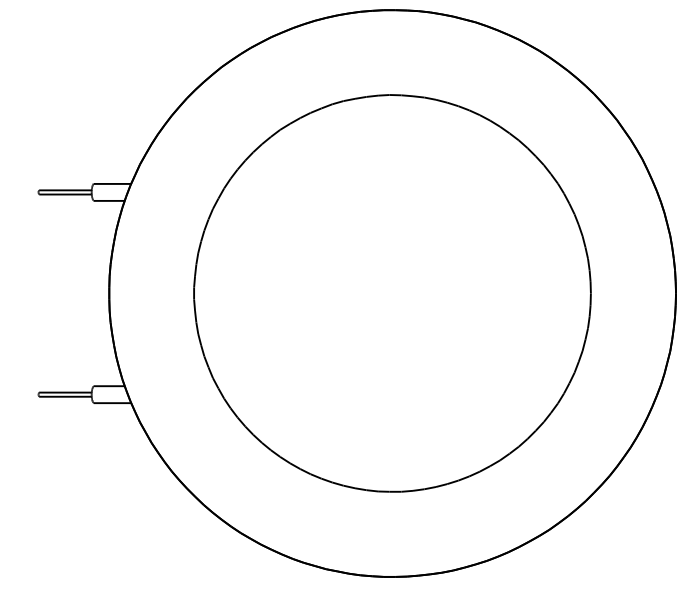
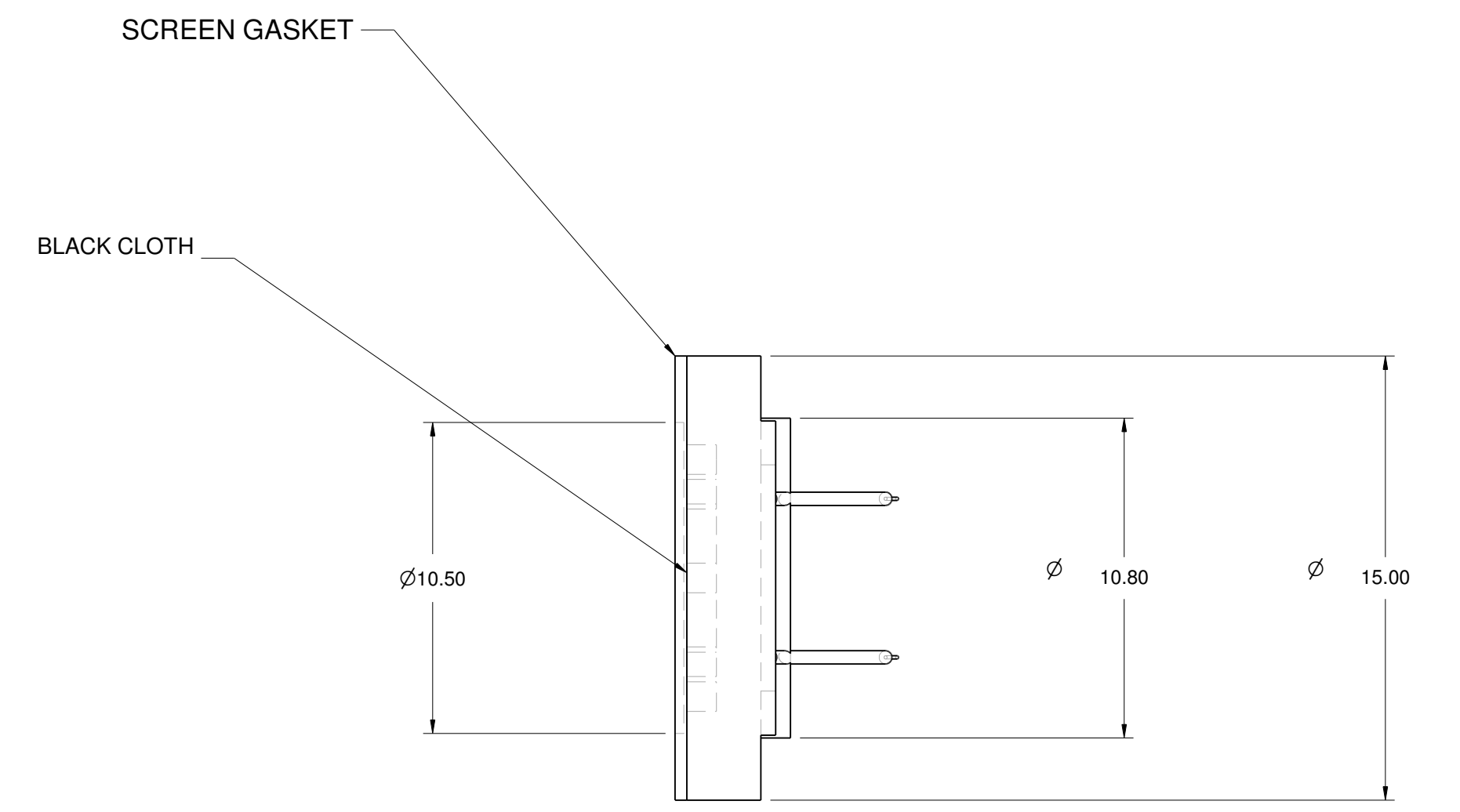
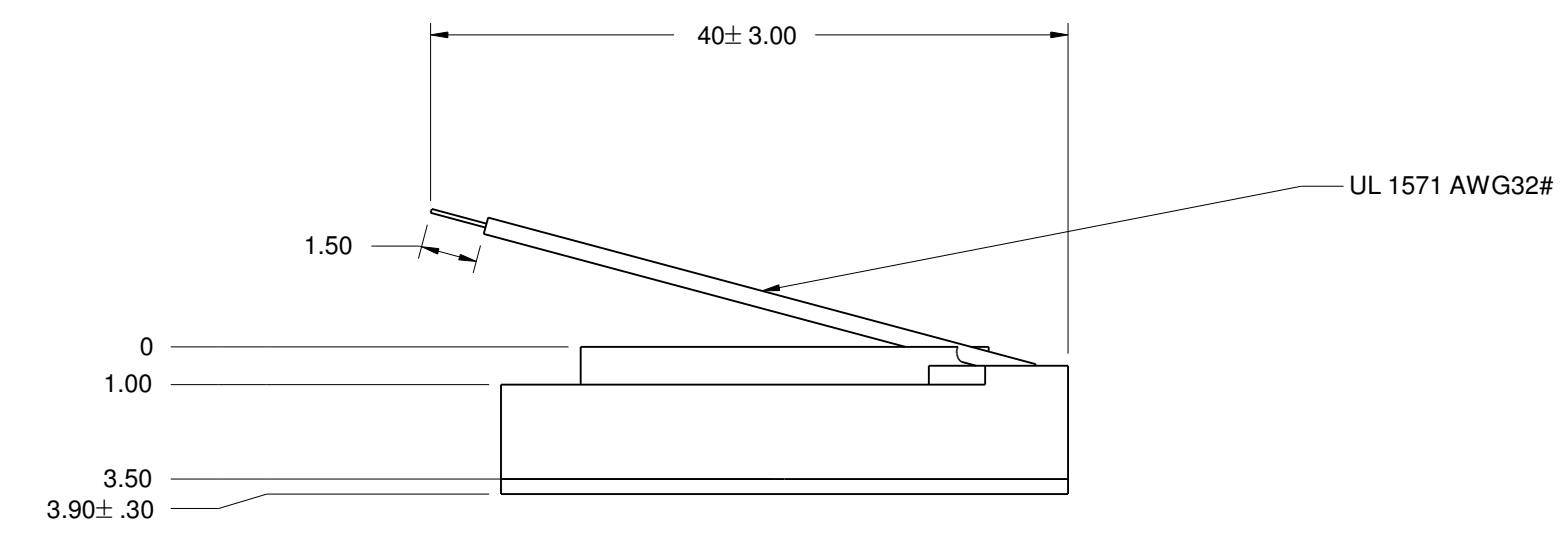

ALL DIMENSIONS IN MM  
TOLERANCE +/- .5MM UNLESS NOTED

SIZE	FSCM NO.	DWG NO.	REV
D		SP-1504-17	
SCALE	1:1	SHEET	1 OF 1