

PART NUMBER	PANEL ID NUMBER	PANEL THICKNESS
EAC511030	030	0.030 - 0.040
EAC511040	040	0.040 - 0.050
EAC511050	050	0.050 - 0.060
EAC511060	060	0.060 - 0.070

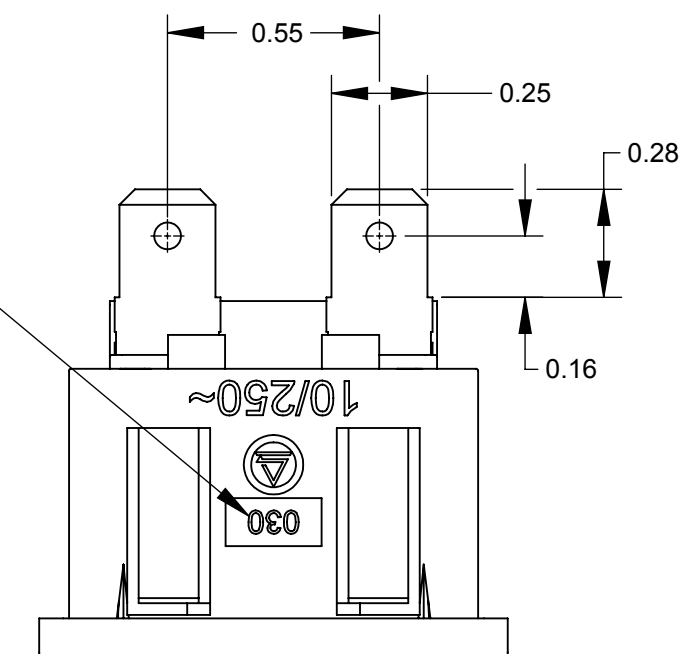

- NOTES:
- AGENCY APPROVAL & RATING:
UL & CSA: 15A 250V
VDE: 10A, 250V
 - MEETS IEC 60320 SPECIFICATION
 - MATERIALS:
HOUSING: BLACK POLYESTER
TERMINALS: TIN PLATED COPPER ALLOY
CONTACT PINS: TIN PLATED COPPER ALLOY

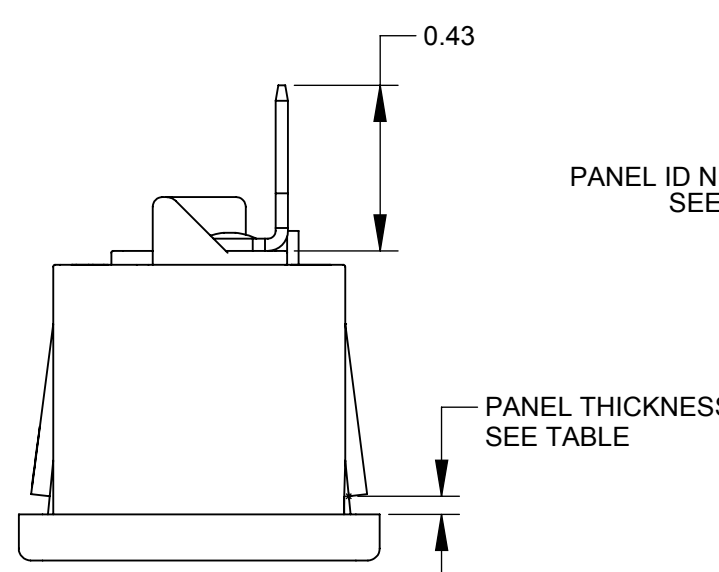
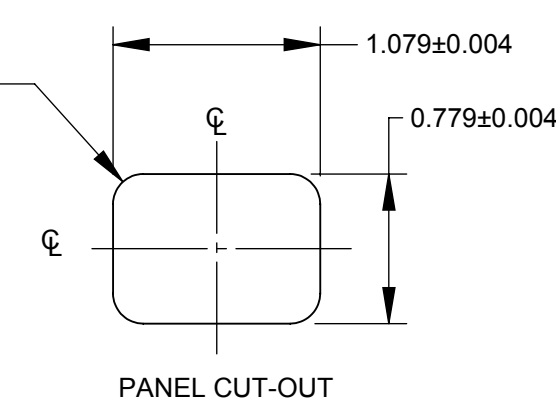
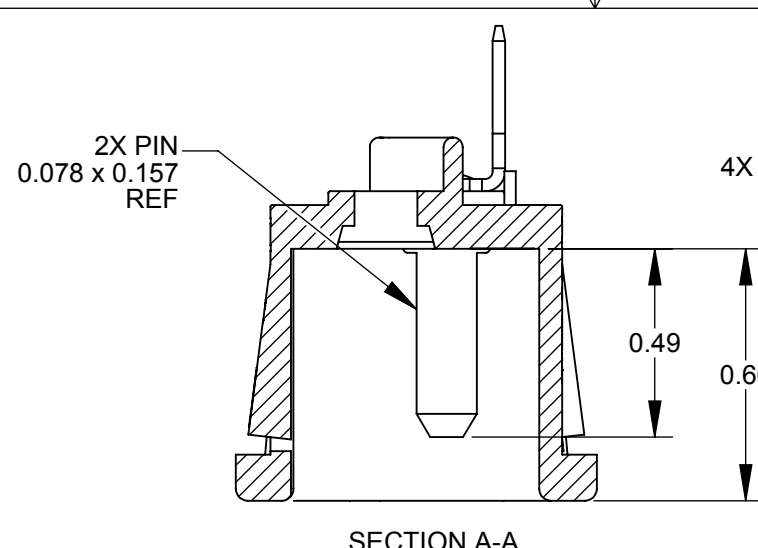
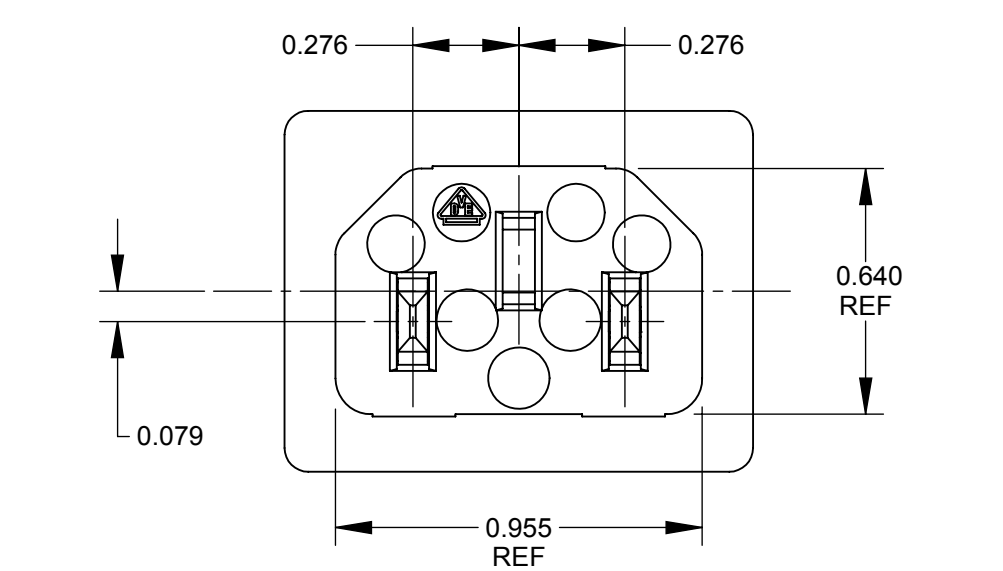
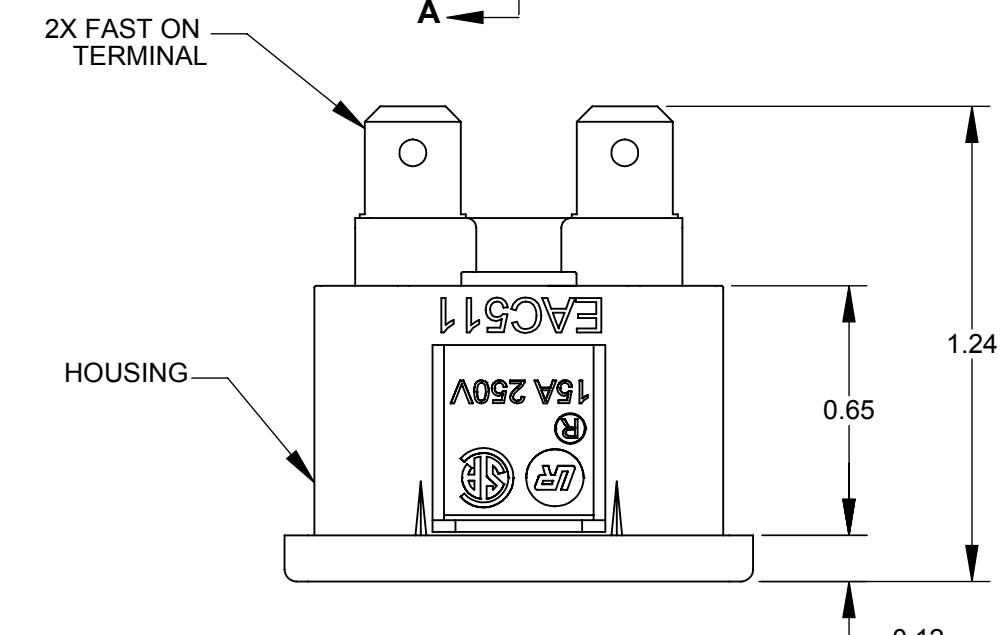
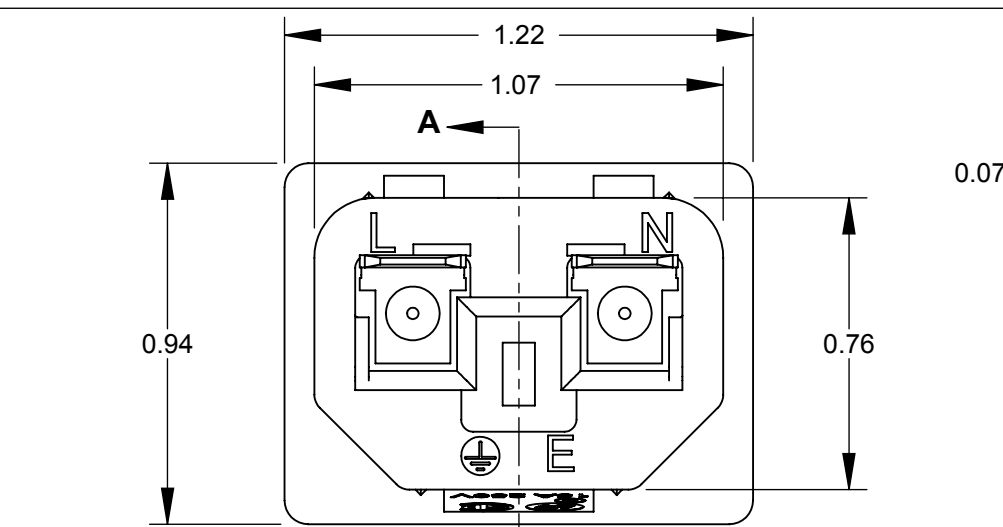
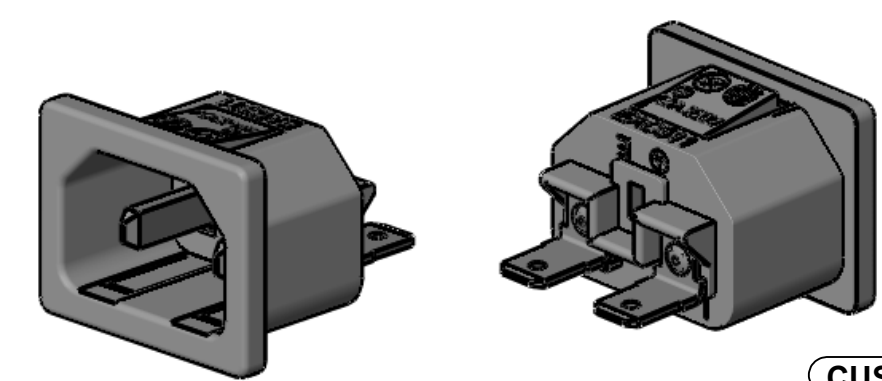

CUSTOMER DRAWING

REVISIONS					UNLESS OTHERWISE SPECIFIED 1. ALL DIMENSIONS IN INCHES - TWO PLACE DECIMALS ±0.02 - THREE PLACE DECIMALS ±0.005	THIS DRAWING DESCRIBES A DESIGN CONSIDERED PROPRIETARY IN NATURE, DEVELOPED AND MANUFACTURED BY SWITCHCRAFT INC. AND IS RELEASED ON A CONFIDENTIAL BASIS FOR IDENTIFICATION PURPOSES ONLY.						
REV	ECO NUMBER	DATE	BY	APVD		SIZE	WIDTH	MULT	LBS/M	TEMPER		
K	26912	02/16/12	BL	TJK	DO NOT SCALE DRAWING	FINISH SPEC No.				MATERIAL SPEC No.		
J	24129	03/27/02	BL	TJK		FIRST USED ON				SCALE 2:1		
					DATE DRAWN 06/05/84				BY THS	CHKD AM	APVD RV	
					NAME 2 PIN SNAP-IN MALE AC RECEPTACLE FAST ON TERMINALS				PART No. EAC511 SERIES	REV K		