

Distributed by:

JAMECO[®]
ELECTRONICS

www.Jameco.com ♦ 1-800-831-4242

The content and copyrights of the attached
material are the property of its owner.

Jameco Part Number 894673

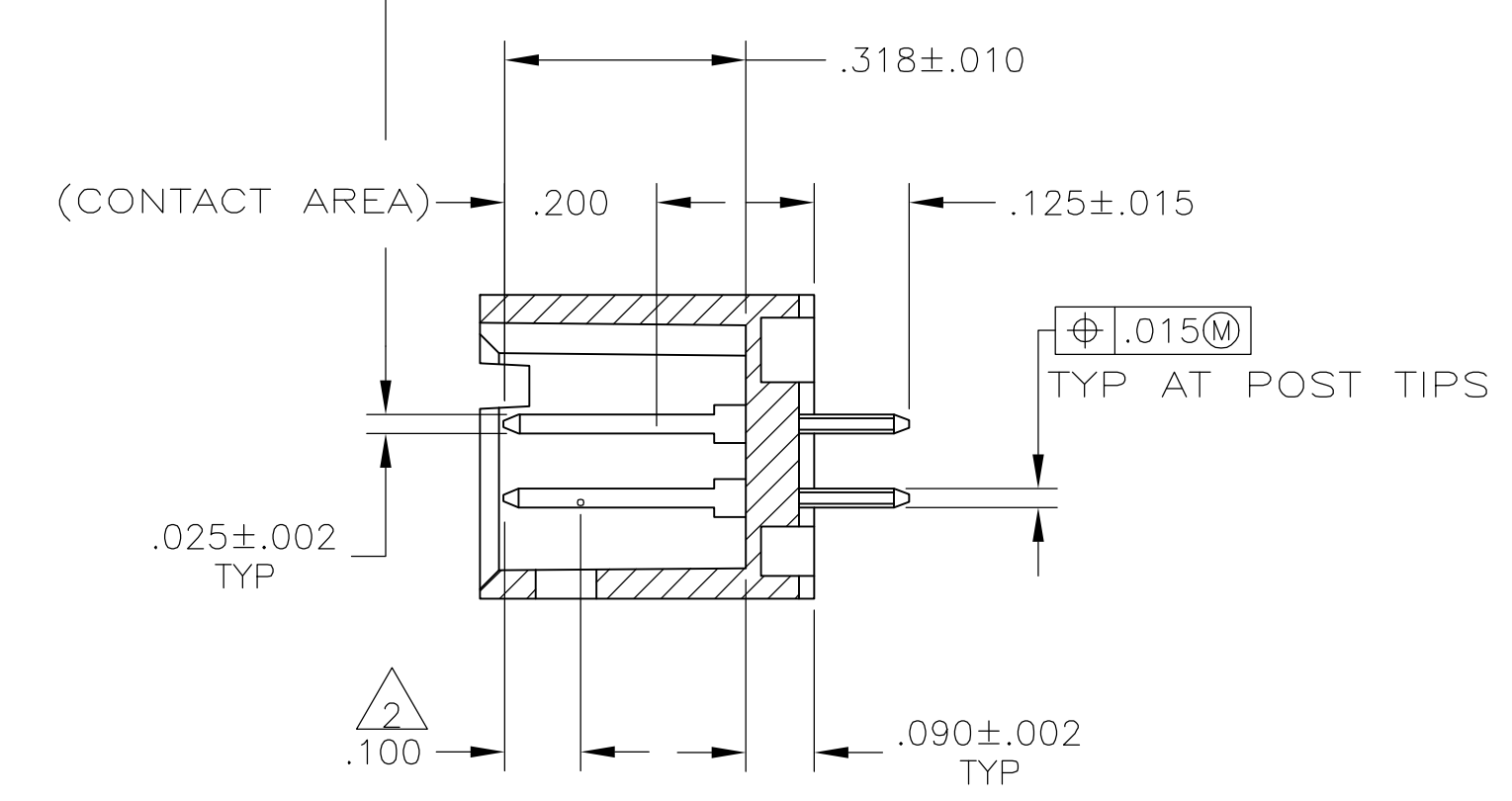
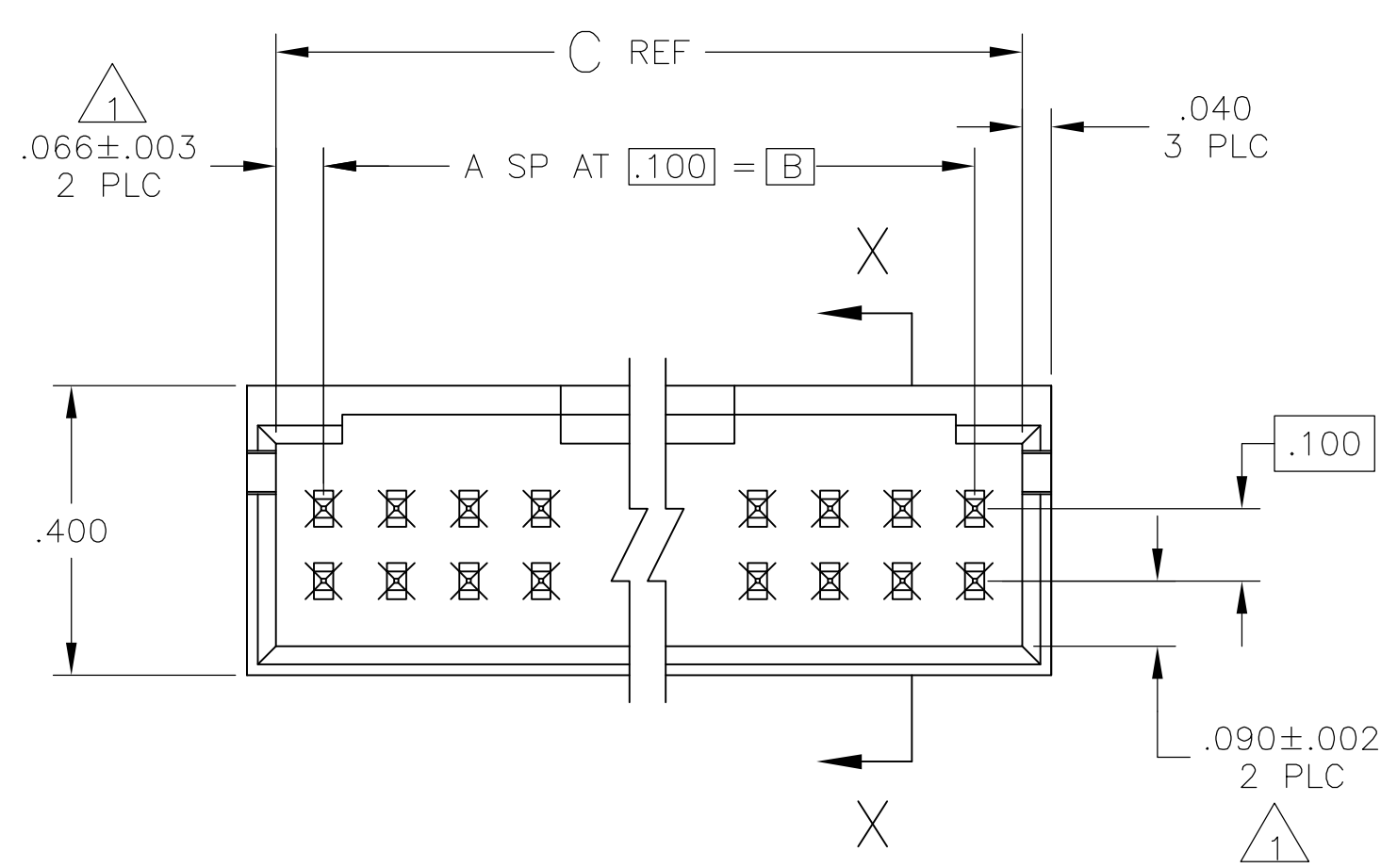
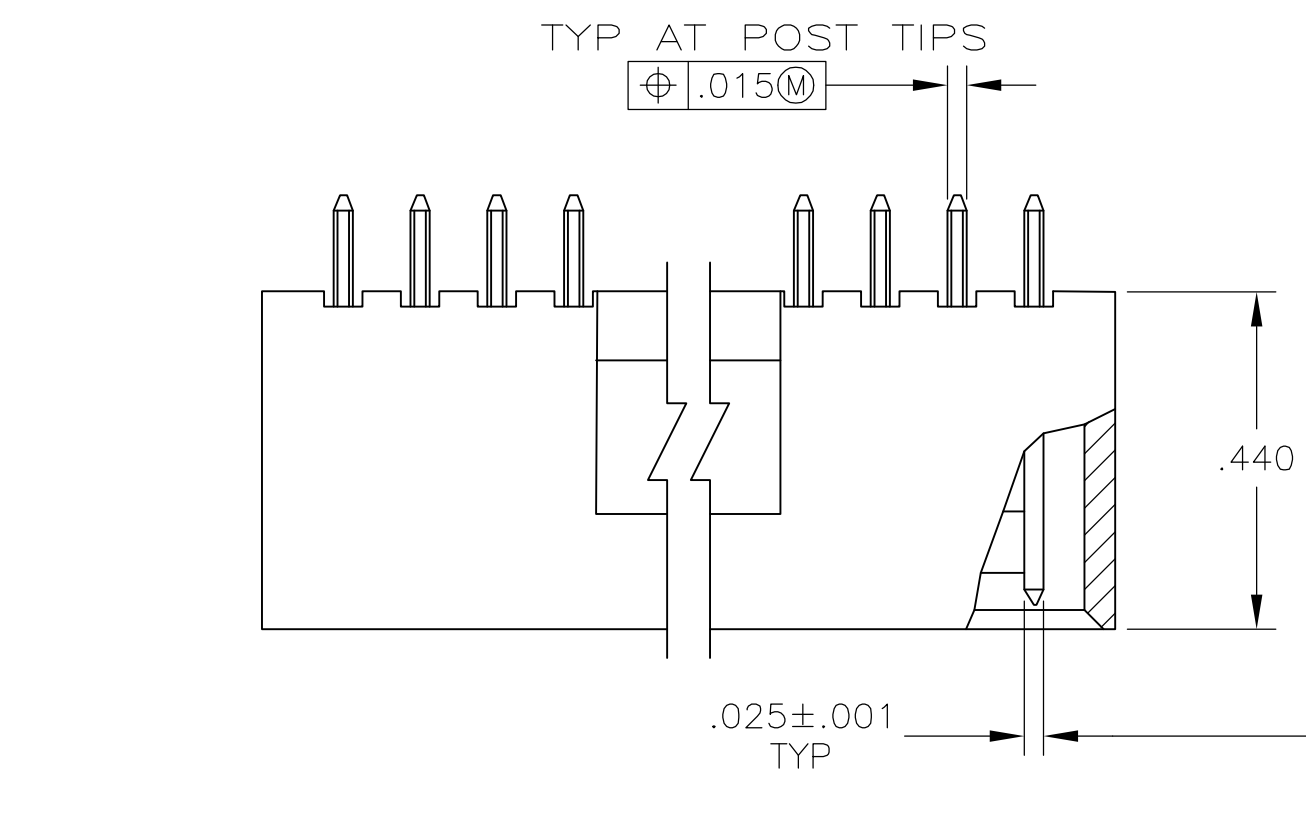

SECTION X-X

- 1 THE NOTED DIMENSIONS APPLY AT THE INTERSECTION OF THE POST AND HOUSING
- 2 POINT OF MEASUREMENT FOR PLATING THICKNESS
- 3 OBSOLETE PART NUMBER
- 4 POSTS: .000030 GOLD IN CONTACT AREA, .000100-.000200 MATTE TIN-LEAD ON SOLDER TAIL, ALL OVER .000050 NICKEL
- 5 POSTS: .000030 GOLD IN CONTACT AREA, .000100-.000200 MATTE TIN ON SOLDER TAIL, ALL OVER .000050 NICKEL

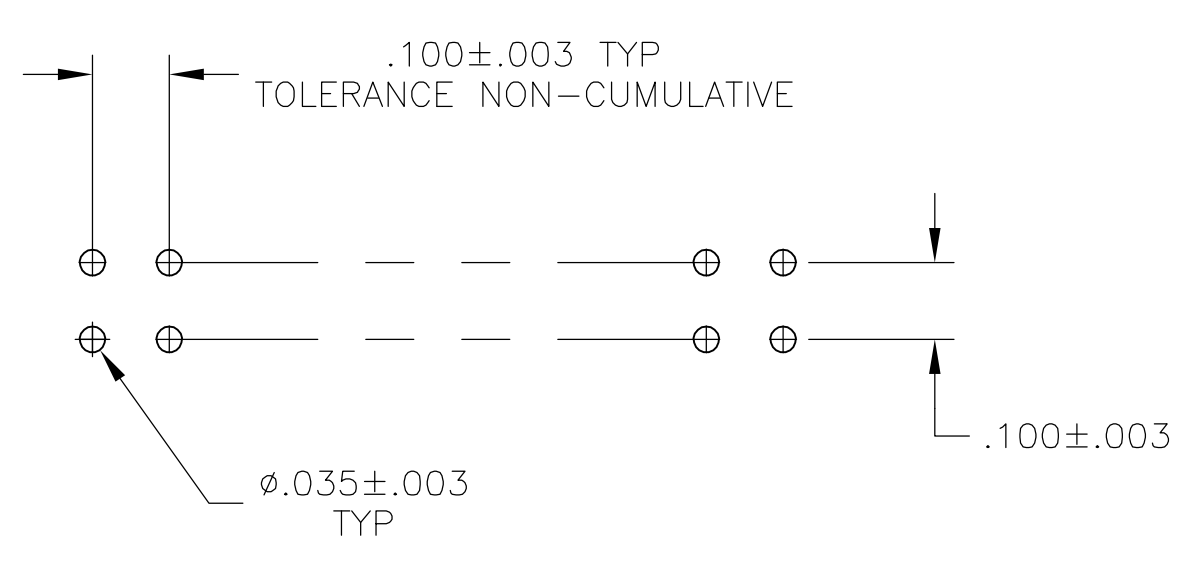
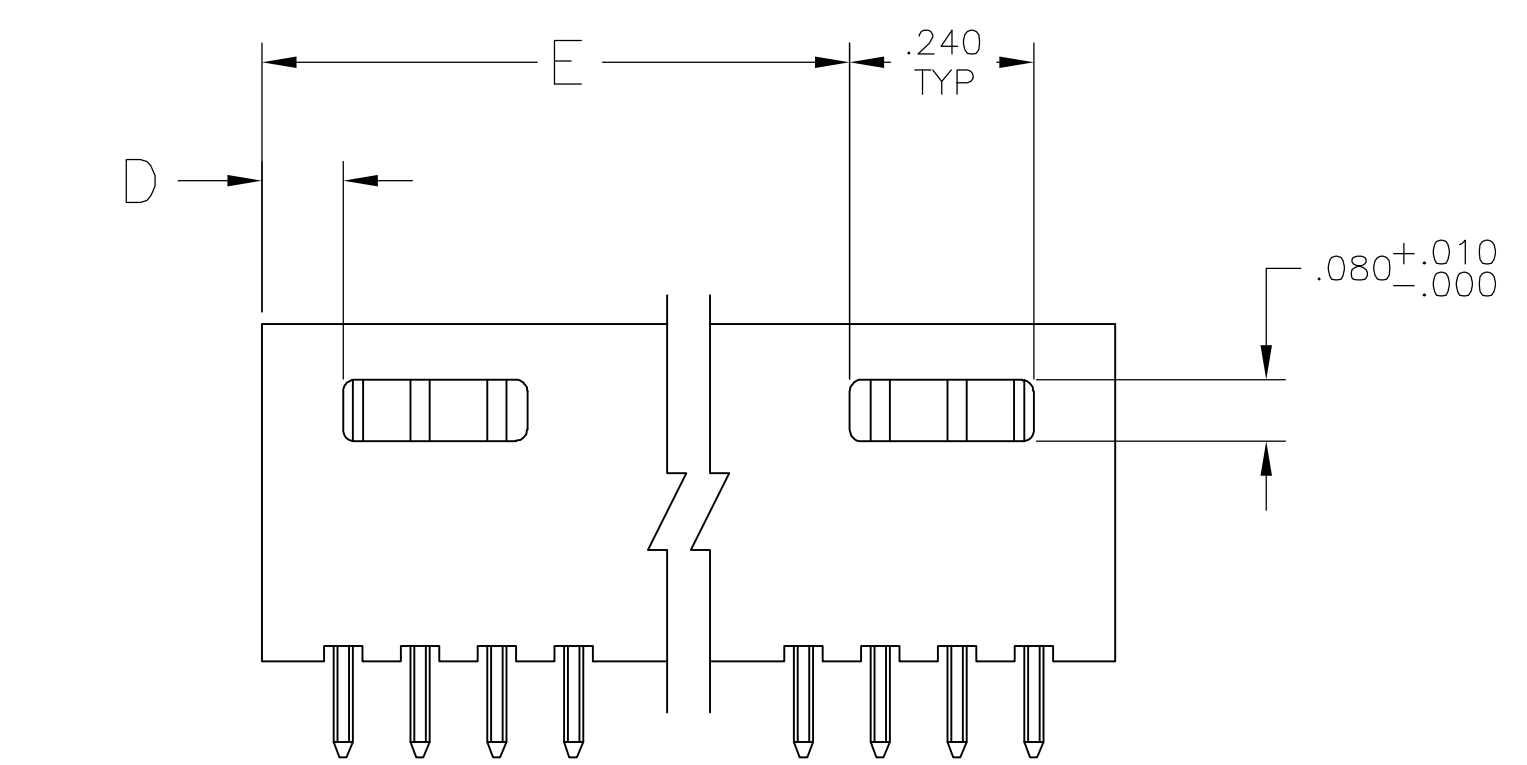

RECOMMENDED HOLE LAYOUT

PLATING	E	D	C	B	A	NO OF POSN	ASSEMBLY PART NUMBER
5	3.506	.106	3.732	3.600	36	74	8-103168-5
5	3.406	.106	3.632	3.500	35	72	8-103168-4
5	3.306	.106	3.532	3.400	34	70	8-103168-3
5	3.206	.106	3.432	3.300	33	68	8-103168-2
5	3.106	.106	3.332	3.200	32	66	8-103168-1
5	3.006	.106	3.232	3.100	31	64	8-103168-0
5	2.906	.106	3.132	3.000	30	62	7-103168-9
5	2.806	.106	3.032	2.900	29	60	7-103168-8
5	2.706	.106	2.932	2.800	28	58	7-103168-7
5	2.606	.106	2.832	2.700	27	56	7-103168-6
5	2.506	.106	2.732	2.600	26	54	7-103168-5
5	2.406	.106	2.632	2.500	25	52	7-103168-4
5	2.306	.106	2.532	2.400	24	50	7-103168-3
5	2.206	.106	2.432	2.300	23	48	7-103168-2
5	2.106	.106	2.332	2.200	22	46	7-103168-1
5	2.006	.106	2.232	2.100	21	44	7-103168-0
5	1.906	.106	2.132	2.000	20	42	6-103168-9
5	1.806	.106	2.032	1.900	19	40	6-103168-8
5	1.706	.106	1.932	1.800	18	38	6-103168-7
5	1.606	.106	1.832	1.700	17	36	6-103168-6
5	1.506	.106	1.732	1.600	16	34	6-103168-5
5	1.406	.106	1.632	1.500	15	32	6-103168-4
5	1.306	.106	1.532	1.400	14	30	6-103168-3
5	1.206	.106	1.432	1.300	13	28	6-103168-2
5	1.106	.106	1.332	1.200	12	26	6-103168-1
5	1.006	.106	1.232	1.100	11	24	6-103168-0
5	.906	.106	1.132	1.000	10	22	5-103168-9
5	.806	.106	1.032	.900	9	20	5-103168-8
5	---	.406	.932	.800	8	18	5-103168-7
5	---	.306	.832	.700	7	16	5-103168-6
5	---	.306	.732	.600	6	14	5-103168-5
5	---	.206	.632	.500	5	12	5-103168-4
5	---	.206	.532	.400	4	10	5-103168-3
5	---	.106	.432	.300	3	8	5-103168-2
5	---	.106	.332	.200	2	6	5-103168-1

PLATING	E	D	C	B	A	NO OF POSN	ASSEMBLY PART NUMBER
4	3.506	.106	3.732	3.600	36	74	3-103168-5
4	3.406	.106	3.632	3.500	35	72	3-103168-4
4	3.306	.106	3.532	3.400	34	70	3-103168-3
4	3.206	.106	3.432	3.300	33	68	3-103168-2
4	3.106	.106	3.332	3.200	32	66	3-103168-1
4	3.006	.106	3.232	3.100	31	64	3-103168-0
4	2.906	.106	3.132	3.000	30	62	2-103168-9
4	2.806	.106	3.032	2.900	29	60	2-103168-8
4	2.706	.106	2.932	2.800	28	58	2-103168-7
4	2.606	.106	2.832	2.700	27	56	2-103168-6
4	2.506	.106	2.732	2.600	26	54	2-103168-5
4	2.406	.106	2.632	2.500	25	52	2-103168-4
4	2.306	.106	2.532	2.400	24	50	2-103168-3
4	2.206	.106	2.432	2.300	23	48	2-103168-2
4	2.106	.106	2.332	2.200	22	46	2-103168-1
4	2.006	.106	2.232	2.100	21	44	2-103168-0
4	1.906	.106	2.132	2.000	20	42	1-103168-9
4	1.806	.106	2.032	1.900	19	40	1-103168-8
4	1.706	.106	1.932	1.800	18	38	1-103168-7
4	1.606	.106	1.832	1.700	17	36	1-103168-6
4	1.506	.106	1.732	1.600	16	34	1-103168-5
4	1.406	.106	1.632	1.500	15	32	1-103168-4
4	1.306	.106	1.532	1.400	14	30	1-103168-3
4	1.206	.106	1.432	1.300	13	28	1-103168-2
4	1.106	.106	1.332	1.200	12	26	1-103168-1
4	1.006	.106	1.232	1.100	11	24	1-103168-0
4	.906	.106	1.132	1.000	10	22	103168-9
4	.806	.106	1.032	.900	9	20	103168-8
4	---	.406	.932	.800	8	18	103168-7
4	---	.306	.832	.700	7	16	103168-6
4	---	.306	.732	.600	6	14	103168-5
4	---	.206	.632	.500	5	12	103168-4
4	---	.206	.532	.400	4	10	103168-3
4	---	.106	.432	.300	3	8	103168-2
4	---	.106	.332	.200	2	6	103168-1

THIS DRAWING IS A CONTROLLED DOCUMENT.

DIMENSIONS: INCHES	TOLERANCES, UNLESS OTHERWISE SPECIFIED:	0 PLC ± -	1 PLC ± -	2 PLC ± -	3 PLC ± .005	4 PLC ± -	ANGLES ± -
MATERIAL: HOUSING: FLAME RETARDANT THERMOPLASTIC; COLOR-BLACK; POSTS: PHOS BRINZE		FINISH: SEE TABLE		WEIGHT: -	SIZE: A1	CAGE CODE: 00779	DRAWING NO: 103168

TYCO Electronics
 Tyco Electronics Corporation
 Harrisburg, Pa 17105-3608

HDR ASSY, MOD II, SHROUDED, 4 SIDES, DBL ROW, VERTICAL, .100X.100, WITH .025 SQ POSTS

CUSTOMER DRAWING SCALE 4:1 SHEET 1 of 1 REV J