

REVISIONS			
REV	DESCRIPTION	DATE	APPROVED
02 <sub>4</sub>	ECN 93-0104	3/8/93	BB <sub>3</sub> /10/93

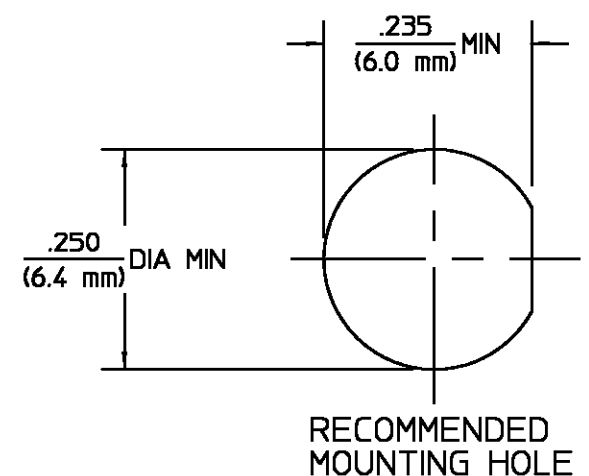

ELECTRICAL	MECHANICAL	ENVIRONMENTAL
Nominal Impedance (Ohms) <u>50</u>	Interface Dimensions MIL-STD-348A, Fig. <u>310.2</u>	Temperature Rating <u>-65°C To 125°C</u>
Frequency Range (GHz) DC to <u>18.0</u>	Recommended Mating Torque <u>7 to 10</u>	Vibration MIL-STD-202, Method 204, Condition D
Volt Rating (VRMS MAX) @ Sea Level <u>335</u>	Mating Characteristics: Insertion (MAX Lbs) <u>3.0</u>	Shock MIL-STD-202, Method 213, Condition I
VSWR <u>N/A</u>	Withdrawal (MIN Oz) <u>1.0</u>	Thermal Shock MIL-STD-202, Method 107, Condition B, Except High Temp +115°C
Insertion Loss (dB MAX) <u>N/A</u>	Force to Engage and Disengage (In-Lbs MAX) <u>2.0</u>	Moisture Resistance MIL-STD-202, Method 106, Except Vibration
RF Leakage (dB MIN) <u>N/A</u>	Center Contact Captivation Axial (Lbs) <u>6.0</u>	Shall Be Omitted
Corona, 70,000 Ft (VRMS MIN) <u>250</u>	Radial (In-Oz) <u>4.0</u>	Corrosion - MIL-STD-202, Method 101, Condition B, 5% salt spray
Dielectric Withstanding Voltage (VRMS MIN) @ Sea Level <u>1000</u>	Cable Retention Axial Force (Lbs) <u>N/A</u>	
Contact Resistance (Milliohms MAX) Center Contact <u>2.0</u>	Torque (In-Oz) <u>N/A</u>	
Outer Contact <u>2.0</u>	Weight (Grams) <u>TBD</u>	
Cable to Housing <u>N/A</u>		
RF High Potential @ Sea Level (VRMS MIN @ 5 MHz) <u>670</u>		
LR.(Megohms MIN) <u>10,000</u>		

COMPONENT	MATERIAL	FINISH
HOUSING MOUNTING NUT LOCKWASHER	STAINLESS STEEL PER ASTM-A484 AND ASTM-A582, TYPE 303	GOLD PLATE PER MIL-G-45204 OVER NICKEL PLATE PER QQ-N-290
DIELECTRIC	TFE FLUOROCARBON PER ASTM-D-1457	N/A
CENTER CONTACT	BERYLLIUM COPPER PER ASTM-B196, ALLOY C17300, CONDITION H	GOLD PLATE PER MIL-G-45204 OVER COPPER PLATE PER MIL-C-14550

UNLESS OTHERWISE SPECIFIED DIMENSIONS ARE IN INCHES TOLERANCE ON	DRAWN BY B.W.C. DATE 6/6/67	 <b>AMP Incorporated</b> 140 Fourth Avenue Waltham, MA 02451-7599								
FRAC. DEC. ANGLES	CHECKED BY P.R.B. 5/9/68									
± 1/64 ±.005 ± °	APP'D BY P.E.G. 6/5/68									
These drawings and specifications are the property of Omni Spectra Incorporated and shall not be reproduced or copied or used in whole or in part as the basis for the manufacture or sale of items without written permission.	USE ASS'Y PROCEDURE	TITLE OSM BULKHEAD FEEDTHRU JACK RECEPTACLE SOLDER POT TERMINAL								
	NO. AP. <u>N/A</u>	<table border="1"> <tr> <td>SIZE B</td> <td>CODE IDENT NO. 26805</td> <td>2056-0000-00</td> <td>REV 02<sub>4</sub></td> </tr> <tr> <td>SCALE 5:1</td> <td colspan="2"></td> <td>SHEET 1 OF 1</td> </tr> </table>	SIZE B	CODE IDENT NO. 26805	2056-0000-00	REV 02 <sub>4</sub>	SCALE 5:1			SHEET 1 OF 1
SIZE B	CODE IDENT NO. 26805	2056-0000-00	REV 02 <sub>4</sub>							
SCALE 5:1			SHEET 1 OF 1							