

THIS DRAWING IS UNPUBLISHED. RELEASED FOR PUBLICATION
 © COPYRIGHT BY TYCO ELECTRONICS CORPORATION. ALL RIGHTS RESERVED.

LOC	DIST	REVISIONS			
P	LTR	DESCRIPTION	DATE	DWN	APVD
AJ	00	B	REV PER ECO 07-027463	17DEC2007	DW JL

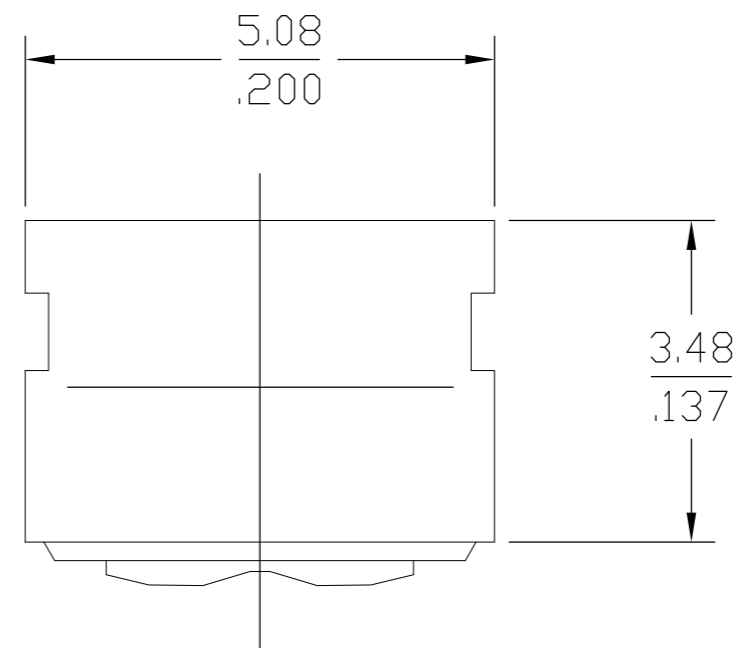
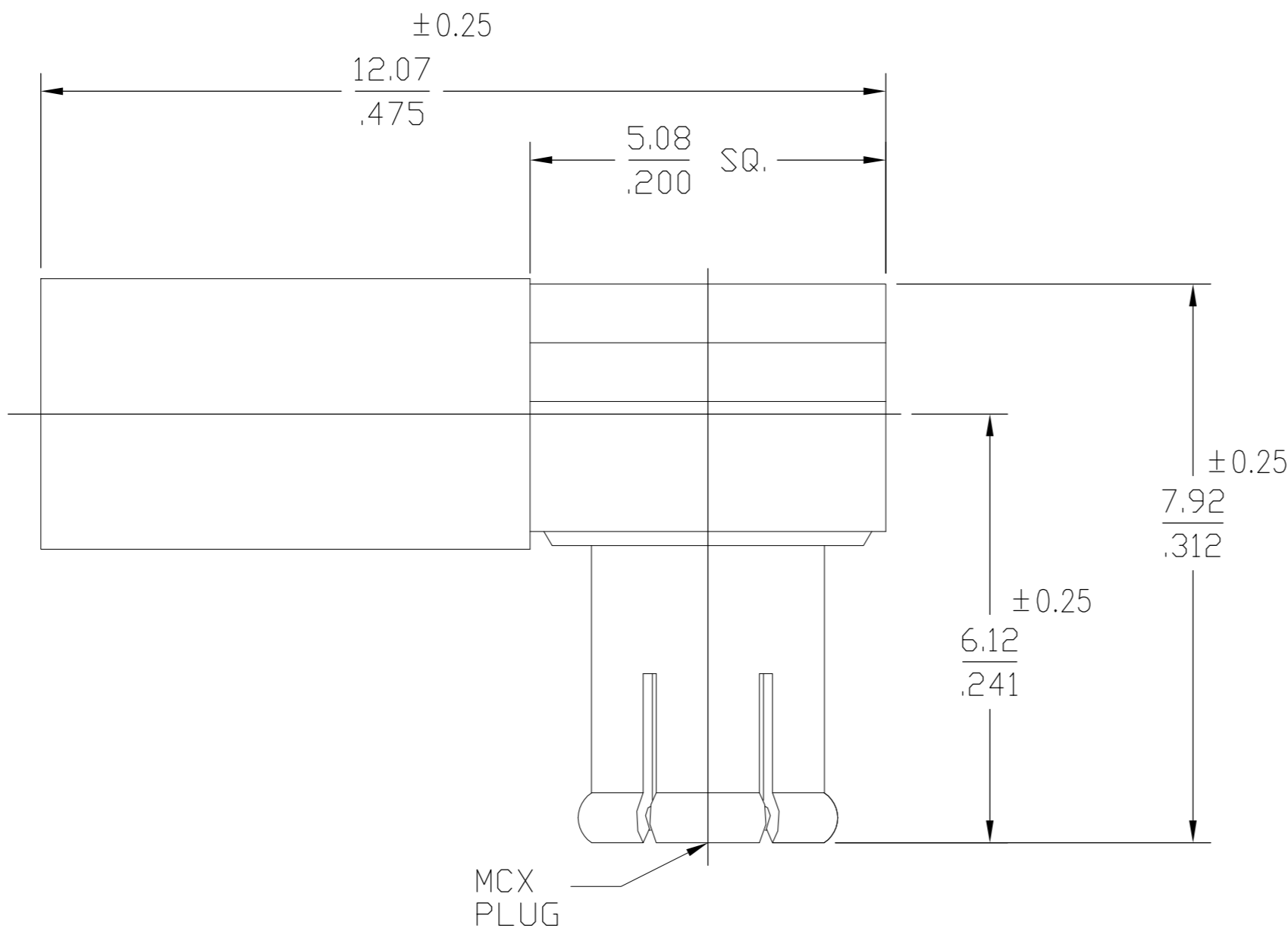

1. SEE INSTRUCTION SHEET
408-4633

1060891-1
PART NUMBER

DESIGNED FOR USE WITH RG-174/U, RG-188/U, RG-316/U, RG-179/U RG-187/U FLEX CABLE & JUNKOSHA CABLE A12B0426	
CABLE ENTRY DIAMETER MINIMUM	
CONTACT	.024 SLOT
HOUSING	.067
FERRULE	.125

XX.X = mm
.XXX = in.

ELECTRICAL	MECHANICAL	ENVIRONMENTAL
Nominal Impedance (Ohms) 50	Force to Engage (lbs MAX) 3.4	TEMPERATURE RATING -65° TO +165°C
Frequency Range (GHz) DC to 6	& Disengage (lbs) 1.77 MIN 4.5 MAX	Vibration MIL-STD-202, Method 204, Condition B
Volt Rating (VRMS MAX) @ Sea Level 335	Center Contact Captivation Designed to Maintain MCX Interface When Mating	Thermal Shock MIL-STD-202, Method 102, Condition B
VSWR 1.25 MAX @ 4 GHz		Moisture Resistance MIL-STD-202, Method 106D, 10 Cycles, 96 Hours
1.35 MAX @ 6 GHz		Corrosion - MIL-STD-202, Method 101, Condition B
Insertion Loss .1dB MAX/1000 MHz		
Corona, 70,000 Ft (VRMS MIN) 250		
Dielectric Withstanding Voltage (VRMS MIN) @ Sea Level 1000		
Contact Resistance (Milliohms MAX)		
Center Contact 5.0		
Outer Contact 1.0		
Cable to Housing 1.0		
RF High Potential @ Sea Level (VRMS MIN @ 5 MHz) 670		
I.R.(Megohms MIN) 10,000		

COMPONENT	MATERIAL	FINISH
HOUSING CAP CENTER CONTACT	BRASS PER ASTM-B-16, HALF HARD	NICKEL PLATE PER QQ-N-290
DIELECTRIC	PTFE FLUOROCARBON PER ASTM-D-1457	N/A
CONTACT FINGERS	BERYLLIUM COPPER PER ASTM-B-196 OR ASTM-B-197, ALLOY C17300, CONDITION H	GOLD PLATE PER MIL-G-45204
FERRULE	COPPER OR BRASS ALLOY ROCKWELL F65 MAXIMUM	NICKEL PLATE PER QQ-N-290

THIS DRAWING IS A CONTROLLED DOCUMENT.		DWN K.C.MAHER 2/20/91	Tyco Electronics Corporation Harrisburg, PA 17105-3608
DIMENSIONS: mm		CHK BB 2/21/91	
TOLERANCES UNLESS OTHERWISE SPECIFIED:		APVD D.R.L. 2/21/91	
0 PLC ± - 1 PLC ± - 2 PLC ± 0.12 .005 3 PLC ± - 4 PLC ± - ANGLES ± 1°		NAME MCX RIGHT ANGLE CABLE PLUG CRIMP ATTACHMENT (5837-5003-10)	
MATERIAL	FINISH	WEIGHT	SIZE A2
-	-	-	CAGE CODE 00779
CUSTOMER DRAWING		SCALE 1:1	DRAWING NO C=1060891-1
		SHEET 1 OF 1	RESTRICTED TO -
		REV B	