

## 1103070-1 Product Details

[Share](#) [Print](#) [Email](#)

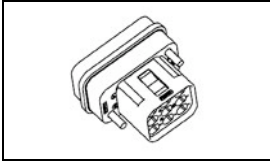

**1103070-1**

TE Internal Number: 1103070-1  
 Active

### HTS Connectors and Accessories

Always EU RoHS/ELV Compliant (Statement of Compliance)

**Product Highlights:**

- HG-Q Series
- Insert
- Insert Style = Pin
- Male
- 9 Poles

[View all Features](#)

### Quick Links

- ▶ [Pricing & Availability](#)
- ▶ [Search for Tooling](#)
- ▶ [Product Feature Selector](#)
- ▶ [Contact Us About This Product](#)

[Add to My Part List](#) [Request Sample](#) [Find Similar Products](#) [Buy Product](#)

Documentation & Additional Information	
<p><b>Product Drawings:</b></p> <ul style="list-style-type: none"> <li>• <a href="#">Cover Pin insert HG-Q8.Sti.C (PDF, English)</a></li> </ul> <p><b>Catalog Pages/Data Sheets:</b></p> <ul style="list-style-type: none"> <li>• <a href="#">HTS Heavy Duty Connectors catalogue (PDF, English)</a></li> </ul> <p><b>Product Specifications:</b></p> <ul style="list-style-type: none"> <li>• None Available</li> </ul> <p><b>Application Specifications:</b></p> <ul style="list-style-type: none"> <li>• None Available</li> </ul> <p><b>Instruction Sheets:</b></p> <ul style="list-style-type: none"> <li>• None Available</li> </ul> <p><b>CAD Files:</b></p> <ul style="list-style-type: none"> <li>• None Available</li> </ul>	<p><b>Additional Information:</b></p> <ul style="list-style-type: none"> <li>• <a href="#">Product Line Information</a></li> </ul> <p><b>Related Products:</b></p> <ul style="list-style-type: none"> <li>• <a href="#">Tooling</a></li> </ul>

[List all Documents](#)

Product Features (Please use the Product Drawing for all design activity)	
<p><b>Product Type Features:</b></p> <ul style="list-style-type: none"> <li>• Product Type = Insert</li> <li>• Gender = Male</li> </ul> <p><b>Body Features:</b></p> <ul style="list-style-type: none"> <li>• Insert Style = Pin</li> <li>• Material = Glass-Filled Thermoplastic</li> </ul> <p><b>Contact Features:</b></p> <ul style="list-style-type: none"> <li>• Number of Poles = 9</li> </ul>	<p><b>Industry Standards:</b></p> <ul style="list-style-type: none"> <li>• <a href="#">RoHS/ELV Compliance</a> = RoHS compliant, ELV compliant</li> <li>• <a href="#">Lead Free Solder Processes</a> = Not relevant for lead free process</li> <li>• <a href="#">RoHS/ELV Compliance History</a> = Always was RoHS compliant</li> </ul> <p><b>Packaging Features:</b></p> <ul style="list-style-type: none"> <li>• Packaging Method = Loose Piece</li> <li>• Packaging Quantity = 10</li> </ul> <p><b>Other:</b></p> <ul style="list-style-type: none"> <li>• Series = HG-Q</li> <li>• Brand = HTS</li> <li>• Comment = Contacts sold separately.</li> </ul>

### Corporate Information

- [About TE](#)
- [Investors](#)
- [News Room](#)
- [Supplier Portal](#)
- [Careers](#)
- [Terms & Conditions](#)
- [Privacy Policy](#)
- [AODA Accessibility Policy](#)
- [AODA Multi-Year Accessibility Plan](#)

### Quick Links

- [Distributor Inventory](#)
- [Product Cross Reference](#)
- [Documents & Drawings](#)
- [Product Compliance Support Center](#)
- [Site Map](#)

### Customer Support

- [Email or Chat With Us](#)
- [Find a Phone Number](#)
- [Knowledge Base](#)
- [Manage Your Account](#)

### Keep Me Informed



4

3

2

1

THIS DRAWING IS UNPUBLISHED. RELEASED FOR PUBLICATION 2006  
 © COPYRIGHT 2000 BY TYCO ELECTRONICS CORPORATION. ALL RIGHTS RESERVED.

LOC	DIST	REVISIONS				
P	LTR	DESCRIPTION	DATE	DWN	APVD	
A1	-	C1	ECR-10-024592	09DEC2010	GW	MH

D

D

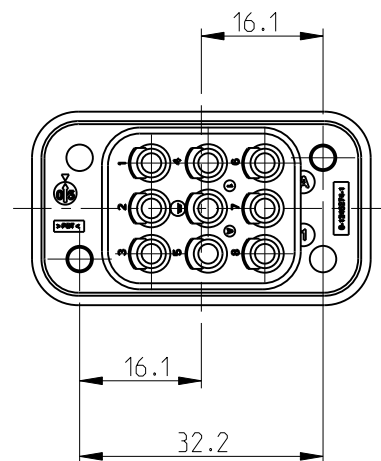

Contact arrangement  
view from termination side

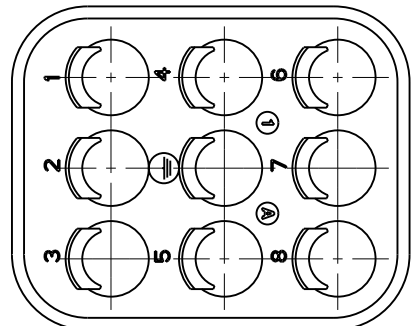

2:1

C

C

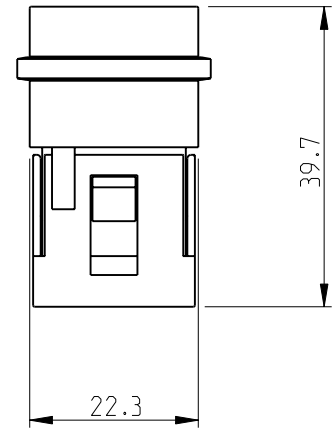
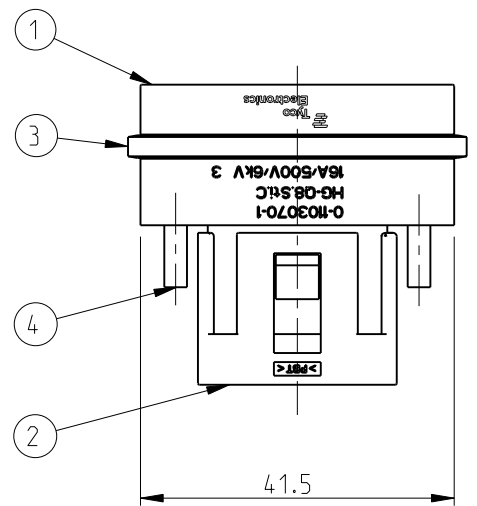

PN 0-1 as shown

B

B

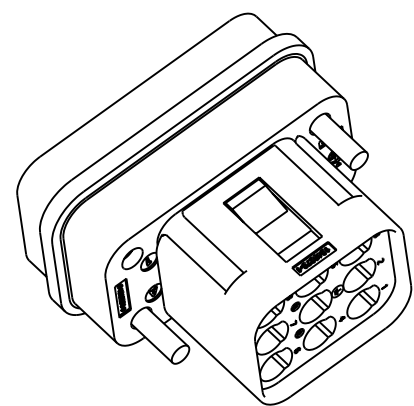

QTY.	DESCRIPTION	MATERIAL	SURFACE	NOTE	ITEM
2	Screw for plastics	Steel	Zinc plated	EJOT DELTA PT 3X10-Z	4
1	Seals	NBR 72	Natural	CONDUCTIVE	3
1	Cover	Crastin	Light Grey	-	2
1	Male insert	Valox	Light Grey	-	1

PARTS LIST

DIMENSIONS: mm 		TOLERANCES UNLESS OTHERWISE SPECIFIED: 0 PLC ± 1 PLC ± 2 PLC ± 3 PLC ± 4 PLC ± ANGLES ±1° FINISH 		DWN M.Schweiger 05.10.04 CHK M.Schweiger 05.10.04 APVD T.Schnurpfel 05.10.04 PRODUCT SPEC 108-74050 APPLICATION SPEC 114-74050 WEIGHT 0.016 KG CUSTOMER DRAWING		Tyco Electronics AMP GmbH D - 53757, Sankt Augustin, Germany NAME Cover Pin insert HG-Q8.Sti.C SIZE A3 CAGE CODE 00779 DRAWING NO C=1103070 RESTRICTED TO - SCALE 2:1 SHEET 1 OF 1 REV C1	
-----------------------	--	---	--	---	--	--	--

A

A