

1103141-1 Product Details

[Share](#) [Print](#) [Email](#)

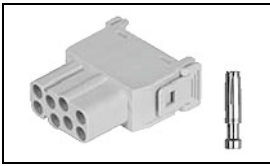

1103141-1

TE Internal Number: 1103141-1

Active

[View 3D PDF](#)

HTS Connectors and Accessories

Always EU RoHS/ELV Compliant (Statement of Compliance)

Product Highlights:

- HVS-HE Series
- Insert
- Contact Configuration = Crimp Terminal
- Insert Style = Socket
- Female

[View all Features](#)

Quick Links

- ▶ [Pricing & Availability](#)
- ▶ [Search for Tooling](#)
- ▶ [Product Feature Selector](#)
- ▶ [Contact Us About This Product](#)

[Add to My Part List](#) [Request Sample](#) [Find Similar Products](#) [Buy Product](#)

Documentation & Additional Information

Product Drawings:

- [FEMALE INSERT ASSY HVS-HE.8.BU.C \(PDF, English\)](#)

Catalog Pages/Data Sheets:

- [1308159-2 HVS High Variable System Modular System Ov... \(PDF, English\)](#)
- [HVS High Variable System - Modul-System Ubersicht \(PDF, German\)](#)

Product Specifications:

- None Available

Application Specifications:

- None Available

Instruction Sheets:

- None Available

CAD Files: (CAD Format & Compression Information)

- [2D Drawing \(DXF, Version B\)](#)
- [3D Model \(IGES, Version B\)](#)
- [3D Model \(STEP, Version B\)](#)

[List all Documents](#)

Additional Information:

- [Product Line Information](#)

Related Products:

- [Tooling](#)

Product Features (Please use the Product Drawing for all design activity)

Product Type Features:

- Product Type = Insert
- Gender = Female
- Finish = Light Gray

Body Features:

- Insert Style = Socket
- Material = PC-GF20

Contact Features:

- Contact Configuration = Crimp Terminal
- Number of Poles = 8

Industry Standards:

- [RoHS/ELV Compliance](#) = RoHS compliant, ELV compliant
- [Lead Free Solder Processes](#) = Not relevant for lead free process
- [RoHS/ELV Compliance History](#) = Always was RoHS compliant

Packaging Features:

- [Packaging Method](#) = Loose Piece
- [Packaging Quantity](#) = 10

Other:

- [Series](#) = HVS-HE
- [Brand](#) = HTS
- [Comment](#) = Contacts sold separately.

Corporate Information

- [About TE](#)
- [Investors](#)
- [News Room](#)
- [Supplier Portal](#)
- [Careers](#)
- [Terms & Conditions](#)
- [Privacy Policy](#)
- [AODA Accessibility Policy](#)
- [AODA Multi-Year Accessibility Plan](#)

Quick Links

- [Distributor Inventory](#)
- [Product Cross Reference](#)
- [Documents & Drawings](#)
- [Product Compliance Support Center](#)
- [Site Map](#)

Customer Support

- [Email or Chat With Us](#)
- [Find a Phone Number](#)
- [Knowledge Base](#)
- [Manage Your Account](#)

Keep Me Informed

THIS DRAWING IS UNPUBLISHED. RELEASED FOR PUBLICATION 2000
 © COPYRIGHT 2000 BY TYCO ELECTRONICS CORPORATION. ALL RIGHTS RESERVED.

LOC	DIST	REVISIONS					
		P	LTR	DESCRIPTION	DATE	DWN	APVD
A1		B1		ECR-10-022648	02NOV2010	SR	OH

PN 0-1 As Shown

Contact arrangement
view from connecting side

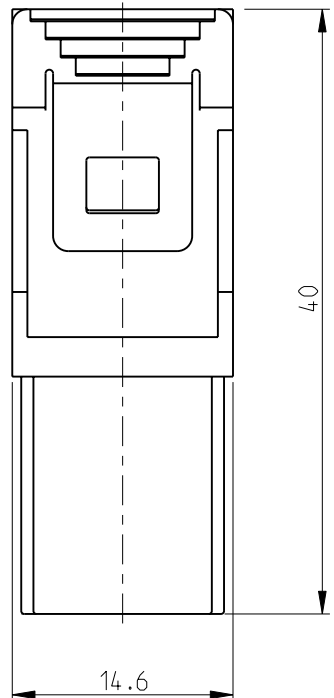
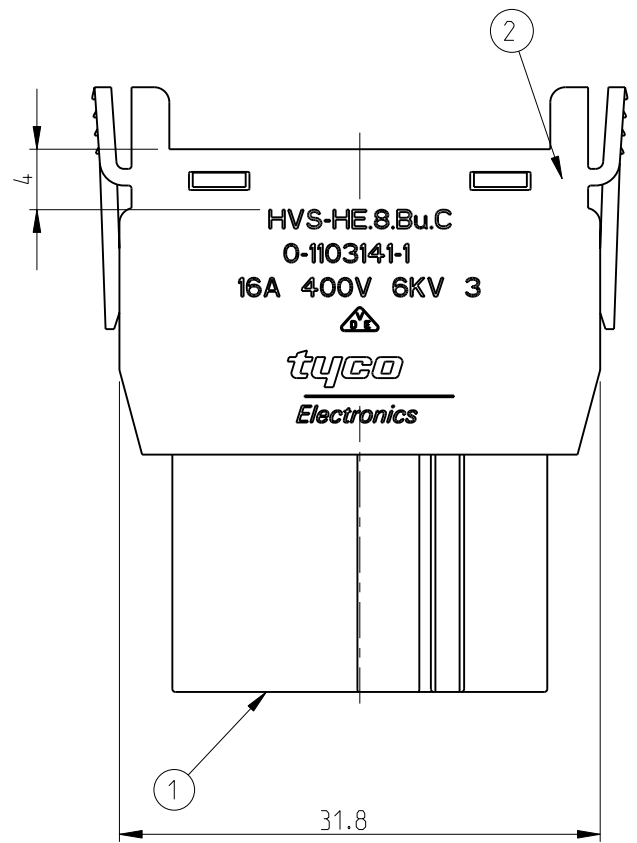
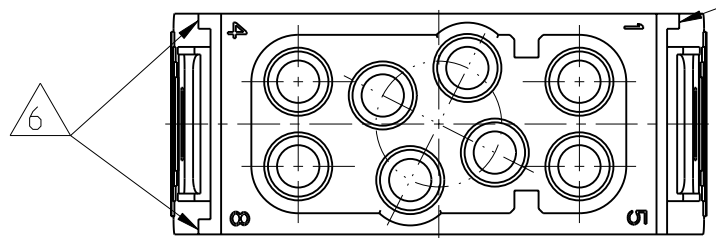

Contact arrangement
view from termination side

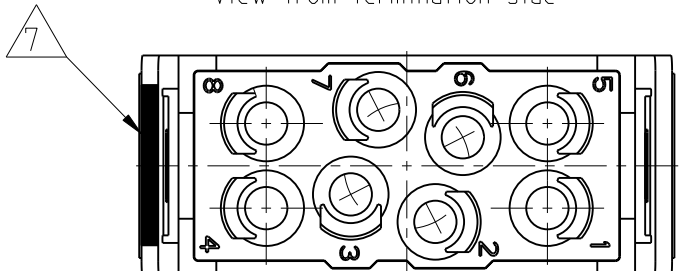

NOTES

- SUITABLE CRIMP CONTACTS: SERIES HE/HA
CUSTOMER DRAWING: 1105101
OUTER DIMENSIONS OF INSULATION: MAX. Ø4.9mm
- SUITABLE MODULE FIXING FRAME: SERIES HVS SIZE 3 TO 8
CUSTOMER DRAWING: 1103250
- SUITABLE INSERTION TOOL:
CUSTOMER DRAWING: 0-1102855-6
- SUITABLE EXTRACTION TOOL:
CUSTOMER DRAWING: 0-1102855-7
- STANDARDS:
DIN EN 61984; DIN EN 60664-1
- △6 POLARIZATION RIPS
- △7 MARKING OF POLARIZATION ACCORDING TO MARKING OF MODULE FRAME
- PACKAGING:
10 SETS IN A CARTON, PRE-MOUNTED

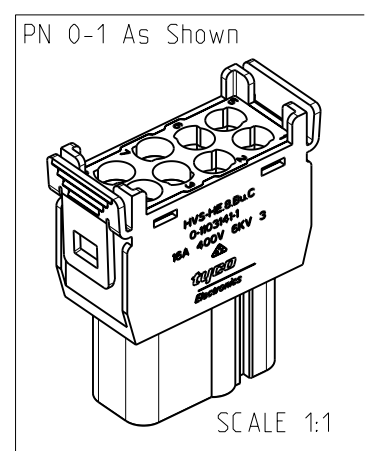

QTY	DESCRIPTION	MATERIAL	COLOR	ITEM NO
1	FEMALE INSERT HVS-HE.8	PC-GF20	LIGHT GREY	1
1	COVER FOR FEMALE INSERT	PC-GF20	LIGHT GREY	2
PN 0-1 / HVS-HE.8.BU.C				

THIS DRAWING IS A CONTROLLED DOCUMENT FOR TYCO ELECTRONICS CORPORATION IT IS SUBJECT TO CHANGE AND THE CONTROLLING ENGINEERING ORGANIZATION SHOULD BE CONTACTED FOR THE LATEST REVISION.		DWN 24.08.2005 M.SCHWEIGER CHK 23.08.2005 T.SCHNURPFIL APVD		Tyco Electronics AMP GmbH 53757 Sankt Augustin, Germany	
DIMENSIONS: mm		TOLERANCES UNLESS OTHERWISE SPECIFIED: ISO 8075 DIN 150.2768 mh-E DIN 15901-120		NAME FEMALE INSERT ASSY HVS-HE.8.BU.C	
		0 PLC ± 1 PLC ± 2 PLC ± 3 PLC ± 4 PLC ± ANGLES ±		PRODUCT SPEC 108-74073 APPLICATION SPEC 114-74073	
MATERIAL △9		FINISH △10		WEIGHT SIZE A3 CAGE CODE 00779 DRAWING NO ©=1103141 RESTRICTED TO	
CUSTOMER DRAWING				SCALE 2:1 SHEET 1 OF 1 REV B1	