

## 1103271-1 Product Details

[Share](#) [Print](#) [Email](#)

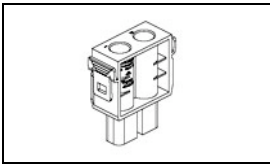

**1103271-1**

TE Internal Number: 1103271-1

Active

[View 3D PDF](#)

### HTS Connectors and Accessories

Always EU RoHS/ELV Compliant (Statement of Compliance)

#### Product Highlights:

- HVS-HSK Series
- Insert
- Contact Configuration = Crimp Terminal
- Insert Style = Socket
- Female

[View all Features](#)

### Quick Links

- ▶ [Pricing & Availability](#)
- ▶ [Search for Tooling](#)
- ▶ [Product Feature Selector](#)
- ▶ [Contact Us About This Product](#)

[Add to My Part List](#) [Request Sample](#) [Find Similar Products](#) [Buy Product](#)

### Documentation & Additional Information

#### Product Drawings:

- [FEMALE INSERT ASSY HVS-HSK.2.BU.C \(PDF, English\)](#)

#### Catalog Pages/Data Sheets:

- [1308159-2 HVS High Variable System Modular System Ov... \(PDF, English\)](#)
- [HVS High Variable System - Modul-System Ubersicht \(PDF, German\)](#)

#### Product Specifications:

- None Available

#### Application Specifications:

- None Available

#### Instruction Sheets:

- None Available

#### CAD Files: (CAD Format & Compression Information)

- [2D Drawing \(DXF, Version C\)](#)
- [3D Model \(IGES, Version C\)](#)
- [3D Model \(STEP, Version C\)](#)

[List all Documents](#)

#### Additional Information:

- [Product Line Information](#)

#### Related Products:

- [Tooling](#)

### Product Features (Please use the Product Drawing for all design activity)

#### Product Type Features:

- Product Type = Insert
- Gender = Female
- Finish = Light Gray

#### Body Features:

- Insert Style = Socket
- Material = PBT-GF

#### Contact Features:

- Contact Configuration = Crimp Terminal
- Number of Poles = 2

#### Industry Standards:

- [RoHS/ELV Compliance](#) = RoHS compliant, ELV compliant
- [Lead Free Solder Processes](#) = Not relevant for lead free process
- [RoHS/ELV Compliance History](#) = Always was RoHS compliant

#### Packaging Features:

- Packaging Method = Loose Piece

#### Other:

- Series = HVS-HSK
- Brand = HTS
- Comment = Contacts sold separately.

### Corporate Information

[About TE](#)  
[Investors](#)  
[News Room](#)  
[Supplier Portal](#)  
[Careers](#)  
[Terms & Conditions](#)  
[Privacy Policy](#)  
[AODA Accessibility Policy](#)  
[AODA Multi-Year Accessibility Plan](#)

### Quick Links

[Distributor Inventory](#)  
[Product Cross Reference](#)  
[Documents & Drawings](#)  
[Product Compliance Support Center](#)  
[Site Map](#)

### Customer Support

[Email or Chat With Us](#)  
[Find a Phone Number](#)  
[Knowledge Base](#)  
[Manage Your Account](#)

### Keep Me Informed

4

3

2

1

THIS DRAWING IS UNPUBLISHED. RELEASED FOR PUBLICATION 2000  
 © COPYRIGHT 2000 BY TYCO ELECTRONICS CORPORATION. ALL RIGHTS RESERVED.

| LOC | DIST | REVISIONS     |           |     |      |
|-----|------|---------------|-----------|-----|------|
| P   | LTR  | DESCRIPTION   | DATE      | DWN | APVD |
|     | C1   | ECR-10-023156 | 11NOV2010 | SR  | OH   |

PN 0-1 As Shown

Contact arrangement view from connecting side

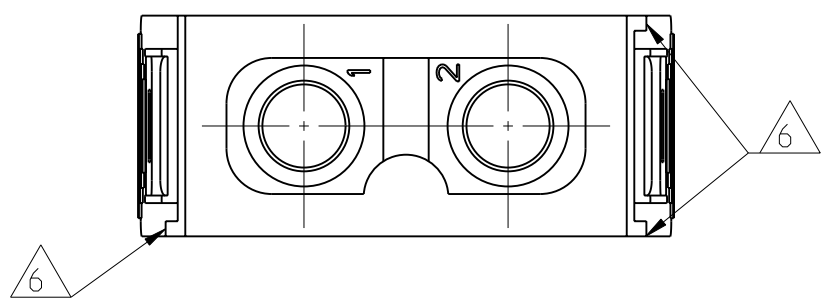

NOTES

- 1 SUITABLE CRIMP CONTACTS: SERIES HSK  
CUSTOMER DRAWING: 1108756  
OUTER DIMENSIONS OF INSULATION: MAX. Ø8mm
- 2 SUITABLE MODULE FIXING FRAME: SERIES HVS SIZE 3 TO 8  
CUSTOMER DRAWING: 1103250
- 3 SUITABLE INSERTION TOOL:  
CUSTOMER DRAWING: 1102855
- 4 SUITABLE EXTRACTION TOOL:  
CUSTOMER DRAWING: 1102855
- 5 STANDARDS:  
DIN EN 61984; DIN EN 60664-1
- 6 POLARIZATION RIPS
- 7 MARKING OF POLARIZATION ACCORDING TO MARKING OF MODULE FRAME
- 8 PACKAGING:  
10 PIECES IN A CARTON

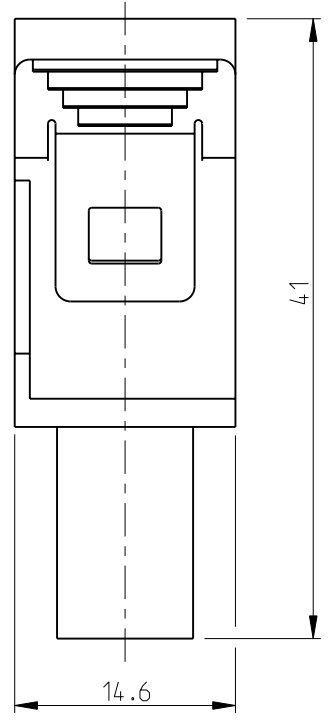
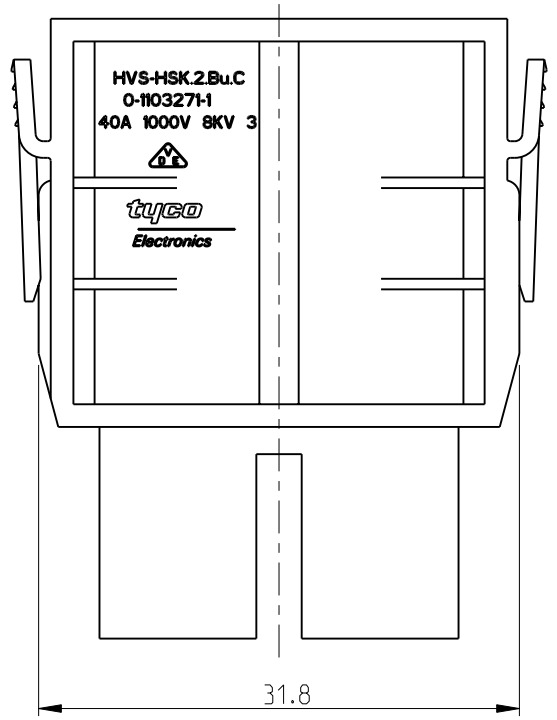

PN 0-1 As Shown

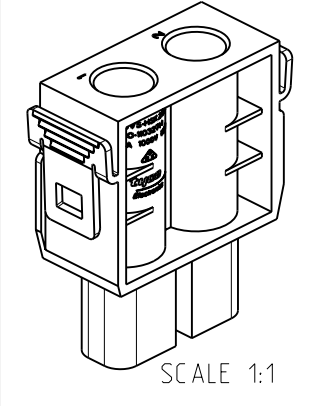

Contact arrangement view from termination side

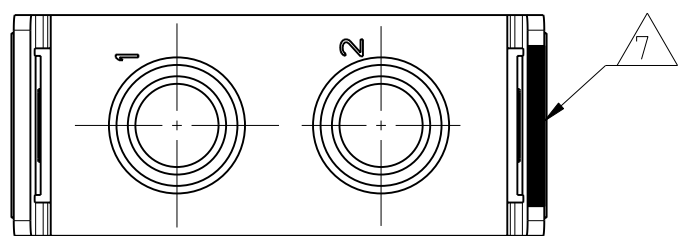

| 1              | DESCRIPTION   | MATERIAL | COLOR      | ITEM NO |
|----------------|---------------|----------|------------|---------|
| 0-1            | FEMALE INSERT | PC-GF20  | LYGHT GREY | 1       |
| HVS-HSK.2.BU.C |               |          |            |         |

|                       |  |   |  |   |                 |  |               |
|-----------------------|--|---|--|---|-----------------|--|---------------|
| DIMENSIONS:<br>mm<br> |  | TOLERANCES UNLESS OTHERWISE SPECIFIED:<br>ISO 8075<br>DIN ISO 2768 mH-E<br>DIN 16901-120<br>0 PLC ±<br>1 PLC ±<br>2 PLC ±<br>3 PLC ±<br>4 PLC ±<br>ANGLES ± |  | DWN 20.02.2006<br>SCHNEIDER<br>CHK 20.02.2006<br>A.GAST<br>APVD 20.02.2006<br>T.SCHNURPFIL<br>PRODUCT SPEC 108-74081<br>APPLICATION SPEC 114-74083<br>WEIGHT 0.008 kg |                 | Tyco Electronics AMP GmbH<br>53757 Sankt Augustin, Germany<br>NAME<br>FEMALE INSERT ASSY<br>HVS-HSK.2.BU.C |               |
| MATERIAL              |  | FINISH  |  | SIZE A3   | CAGE CODE 00779 | DRAWING NO C=1103271   | RESTRICTED TO |
| CUSTOMER DRAWING      |  |   |  | SCALE 2:1   | SHEET 1 OF 1    | REV C1   |               |