

## 1103276-1 Product Details

[Share](#) [Print](#) [Email](#)

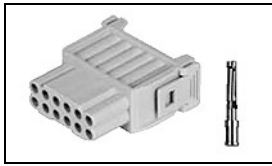

**1103276-1**

TE Internal Number: 1103276-1

Active

[View 3D PDF](#)

### HTS Connectors and Accessories

Always EU RoHS/ELV Compliant (Statement of Compliance)

#### Product Highlights:

- HVS-HN Series
- Insert
- Contact Configuration = Crimp Terminal
- Insert Style = Socket
- Female

[View all Features](#)

### Quick Links

- ▶ [Pricing & Availability](#)
- ▶ [Search for Tooling](#)
- ▶ [Product Feature Selector](#)
- ▶ [Contact Us About This Product](#)

[Add to My Part List](#) [Request Sample](#) [Find Similar Products](#) [Buy Product](#)

### Documentation & Additional Information

#### Product Drawings:

- [FEMALE INSERT HVS-HND.12.BU.C \(PDF, English\)](#)

#### Catalog Pages/Data Sheets:

- [1308159-2 HVS High Variable System Modular System Ov... \(PDF, English\)](#)
- [HVS High Variable System - Modul-System Ubersicht \(PDF, German\)](#)

#### Product Specifications:

- None Available

#### Application Specifications:

- None Available

#### Instruction Sheets:

- None Available

#### CAD Files: (CAD Format & Compression Information)

- [2D Drawing \(DXF, Version B\)](#)
- [3D Model \(IGES, Version B\)](#)
- [3D Model \(STEP, Version B\)](#)

[List all Documents](#)

#### Additional Information:

- [Product Line Information](#)

#### Related Products:

- [Tooling](#)

### Product Features (Please use the Product Drawing for all design activity)

#### Product Type Features:

- Product Type = Insert
- Gender = Female
- Finish = Light Gray

#### Body Features:

- Insert Style = Socket
- Material = PC-GF20

#### Contact Features:

- Contact Configuration = Crimp Terminal
- Number of Poles = 12

#### Industry Standards:

- [RoHS/ELV Compliance](#) = RoHS compliant, ELV compliant
- [Lead Free Solder Processes](#) = Not relevant for lead free process
- [RoHS/ELV Compliance History](#) = Always was RoHS compliant

#### Packaging Features:

- Packaging Method = Loose Piece

#### Other:

- Series = HVS-HN
- Brand = HTS
- Comment = Contacts sold separately.

### Corporate Information

- [About TE](#)
- [Investors](#)
- [News Room](#)
- [Supplier Portal](#)
- [Careers](#)
- [Terms & Conditions](#)
- [Privacy Policy](#)
- [AODA Accessibility Policy](#)
- [AODA Multi-Year Accessibility Plan](#)

### Quick Links

- [Distributor Inventory](#)
- [Product Cross Reference](#)
- [Documents & Drawings](#)
- [Product Compliance Support Center](#)
- [Site Map](#)

### Customer Support

- [Email or Chat With Us](#)
- [Find a Phone Number](#)
- [Knowledge Base](#)
- [Manage Your Account](#)

### Keep Me Informed

4

3

2

1

THIS DRAWING IS UNPUBLISHED. RELEASED FOR PUBLICATION 2000  
 © COPYRIGHT 2000 BY TYCO ELECTRONICS CORPORATION. ALL RIGHTS RESERVED.

LOC	DIST	REVISIONS					
		P	LTR	DESCRIPTION	DATE	DWN	APVD
A1		B1		ECR-10-022648	26.10.2010	SR	OH

Contact arrangement  
view from connecting side

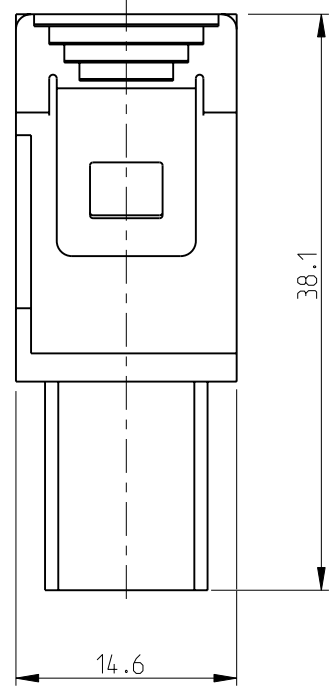
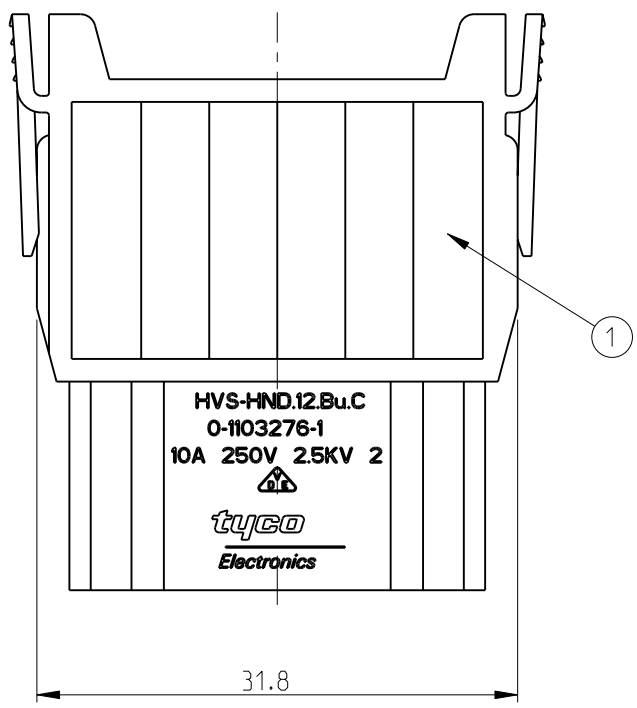
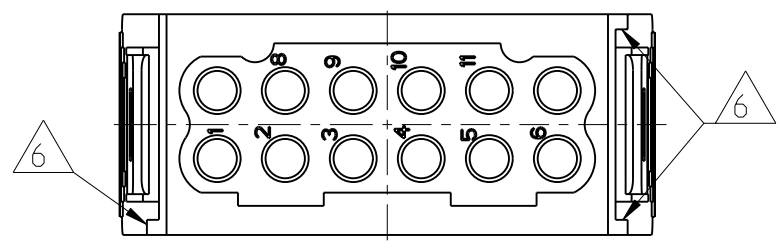

Contact arrangement  
view from termination side

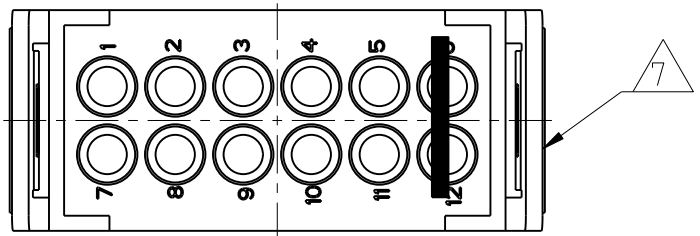

NOTES

- 1 SUITABLE CRIMP CONTACTS: SERIES HN.D  
CUSTOMER DRAWING: 1105051  
OUTER DIMENSIONS OF INSULATION: MAX. Ø4mm
- 2 SUITABLE MODULE FIXING FRAME: SERIES HVS SIZE 3 TO 8  
CUSTOMER DRAWING: 1103250
- 3 SUITABLE INSERTION TOOL:  
CUSTOMER DRAWING: 1102855
- 4 SUITABLE EXTRACTION TOOL:  
CUSTOMER DRAWING: 1102855
- 5 STANDARDS:  
DIN EN 61984; DIN EN 60664-1
- 6 POLARIZATION RIPS
- 7 MARKING OF POLARIZATION ACCORDING TO MARKING OF  
MODULE FRAME
- 8 PACKAGING:  
10 PIECES IN A CARTON

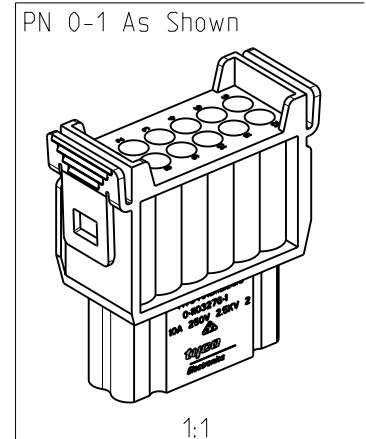

PN 0-1 AS SHOWN

QTY	DESCRIPTION	MATERIAL	COLOR	ITEM NO
1	FEMALE INSERT	PC-GF20	LIGHT GREY	1
PN 0-1 / HVS-HND.12.BU.C				

THIS DRAWING IS A CONTROLLED DOCUMENT FOR TYCO ELECTRONICS CORPORATION IT IS SUBJECT TO CHANGE AND THE CONTROLLING ENGINEERING ORGANIZATION SHOULD BE CONTACTED FOR THE LATEST REVISION.		DWN SCHNEIDER 20.2.2006 CHK A.GAST 20.2.2006 APVD T.SCHNURPFIL 20.2.2006		<b>Tyco Electronics</b> Tyco Electronics AMP GmbH 53757 Sankt Augustin, Germany	
DIMENSIONS: mm		TOLERANCES UNLESS OTHERWISE SPECIFIED: ISO 8075 DIN ISO 2768 mH-E DIN 16901-120		NAME <b>FEMALE INSERT HVS-HND.12.BU.C</b>	
		0 PLC ± 1 PLC ± 2 PLC ± 3 PLC ± 4 PLC ± ANGLES ±		PRODUCT SPEC 108-74083 APPLICATION SPEC 114-74085	
MATERIAL 		FINISH 		SIZE A3 CAGE CODE 00779 DRAWING NO ©=1103276 RESTRICTED TO	
CUSTOMER DRAWING				SCALE 2:1 SHEET 1 OF 1 REV B1	