

## 1106410-2 Product Details

[Share](#) [Print](#) [Email](#)

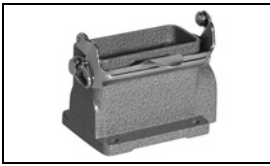

**1106410-2**

TE Internal Number: 1106410-2

Active

[View 3D PDF](#)

### HTS Connectors and Accessories

Always EU RoHS/ELV Compliant (Statement of Compliance)

#### Product Highlights:

- HA Series
- Housing
- Product Size = 2
- Locking Device Type = Side Clip at Housing Bottom
- Side Entry Style

[View all Features](#)

### Quick Links

- ▶ [Pricing & Availability](#)
- ▶ [Search for Tooling](#)
- ▶ [Product Feature Selector](#)
- ▶ [Contact Us About This Product](#)

[Add to My Part List](#) [Request Sample](#) [Find Similar Products](#) [Buy Product](#)

### Documentation & Additional Information

#### Product Drawings:

- [SURFACE MOUNTED HOUSING HA.10 \(PDF, English\)](#)

#### Catalog Pages/Data Sheets:

- [HTS Heavy Duty Connectors catalogue \(PDF, English\)](#)

#### Product Specifications:

- None Available

#### Application Specifications:

- None Available

#### Instruction Sheets:

- None Available

#### CAD Files: [\(CAD Format & Compression Information\)](#)

- [2D Drawing \(DXF, Version B3\)](#)
- [3D Model \(IGES, Version B3\)](#)
- [3D Model \(STEP, Version B3\)](#)

[List all Documents](#)

#### Additional Information:

- [Product Line Information](#)

#### Related Products:

- [Tooling](#)

### Product Features (Please use the Product Drawing for all design activity)

#### Product Type Features:

- Product Type = Housing
- Product Size = 2
- [Thread Size](#) = 2xM20
- Finish = Silver Gray

#### Body Features:

- Entry Style = Side
- Dimensions (L x H x W) (mm [in]) = 72.5 x 47.0 x 50.0 [2.86 x 1.85 x 1.97]
- Material = Die Cast Aluminum

#### Contact Features:

- Corrosion Protected = No

#### Configuration Features:

- Locking Device Type = Side Clip at Housing Bottom

#### Industry Standards:

- [RoHS/ELV Compliance](#) = RoHS compliant, ELV compliant
- [Lead Free Solder Processes](#) = Not relevant for lead free process
- [RoHS/ELV Compliance History](#) = Always was RoHS compliant

#### Packaging Features:

- [Packaging Method](#) = Loose Piece
- [Packaging Quantity](#) = 5

#### Other:

- [Series](#) = HA
- [Brand](#) = HTS

### Corporate Information

- [About TE](#)
- [Investors](#)
- [News Room](#)
- [Supplier Portal](#)
- [Careers](#)
- [Terms & Conditions](#)
- [Privacy Policy](#)
- [AODA Accessibility Policy](#)

### Quick Links

- [Distributor Inventory](#)
- [Product Cross Reference](#)
- [Documents & Drawings](#)
- [Product Compliance Support Center](#)
- [Site Map](#)

### Customer Support

- [Email or Chat With Us](#)
- [Find a Phone Number](#)
- [Knowledge Base](#)
- [Manage Your Account](#)

### Keep Me Informed

PN 0-2 & 0-5

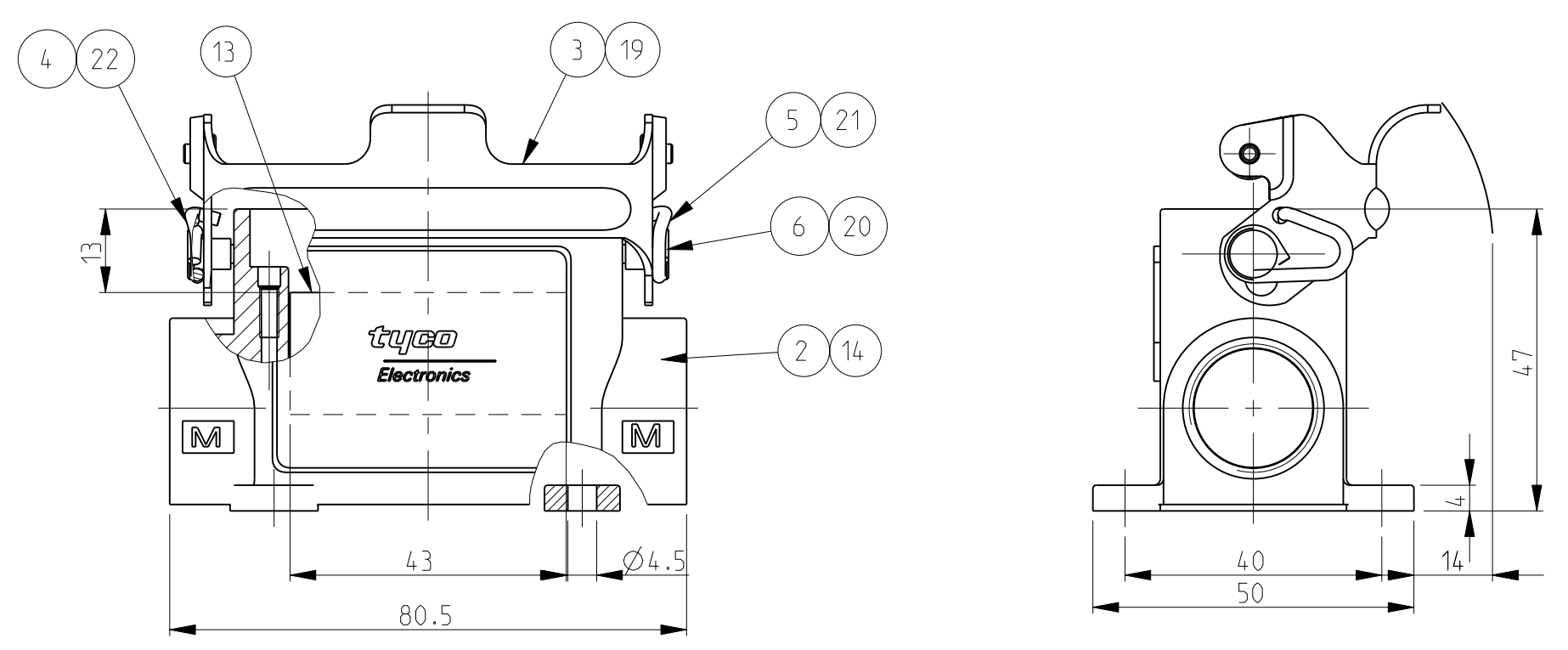

- NOTES
- 1 PACKAGING QUANTITY: 5 PIECES PER BOX
  - 2 MATERIAL: HOUSING: ALUMINIUM DIECASTING ALLOY  
SEAL: NEOPRENE
  - 3 SURFACE: VARNISH GREY
  - 4 VARNISH ON THE INSIDE NOT NECESSARY

PN 0-1

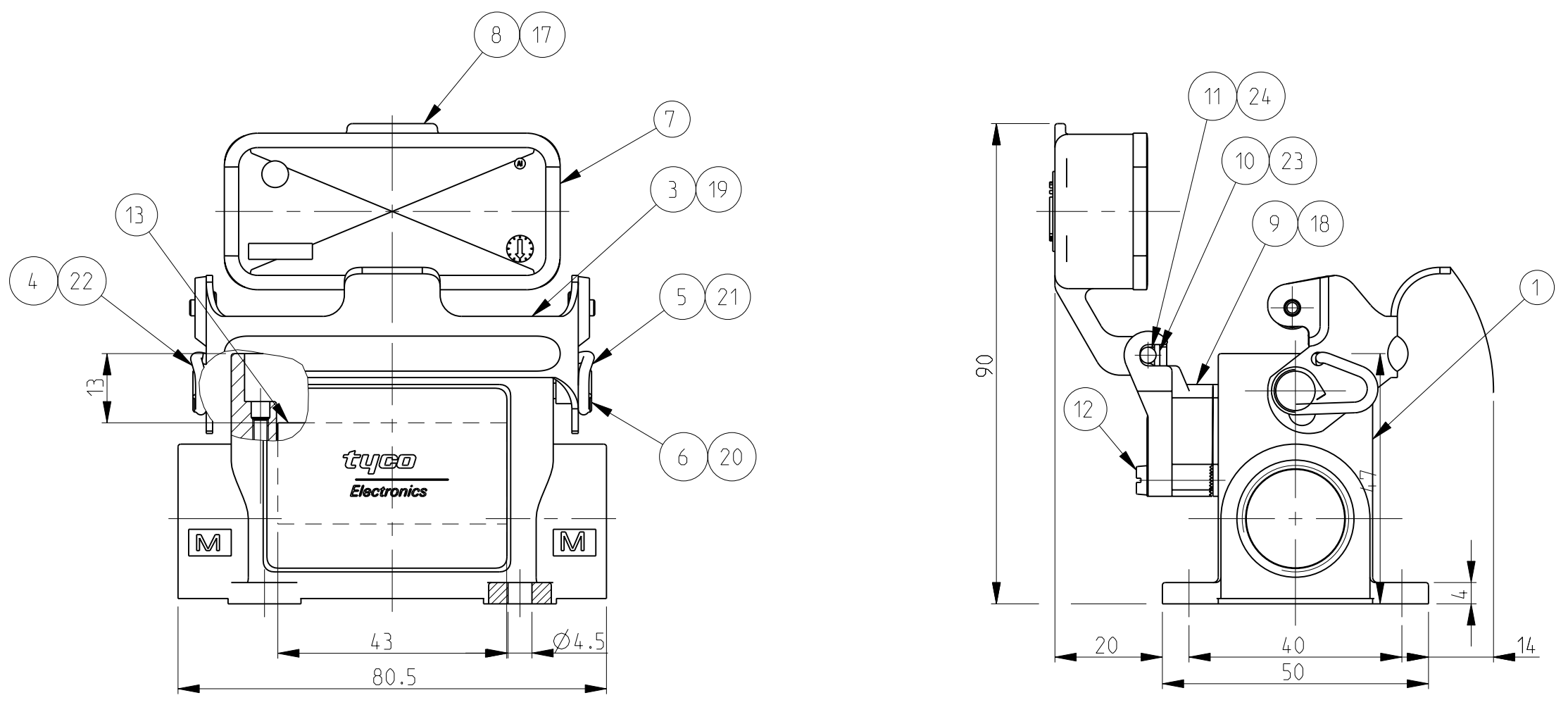

PN 0-6

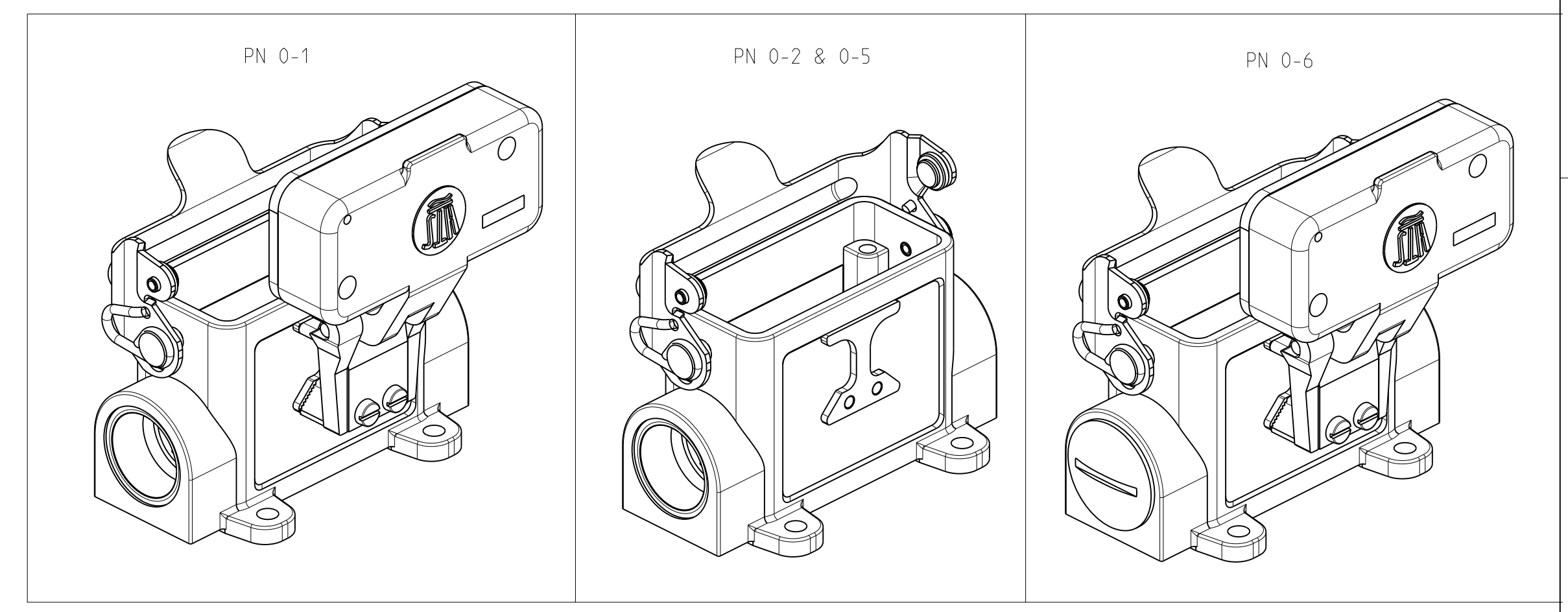
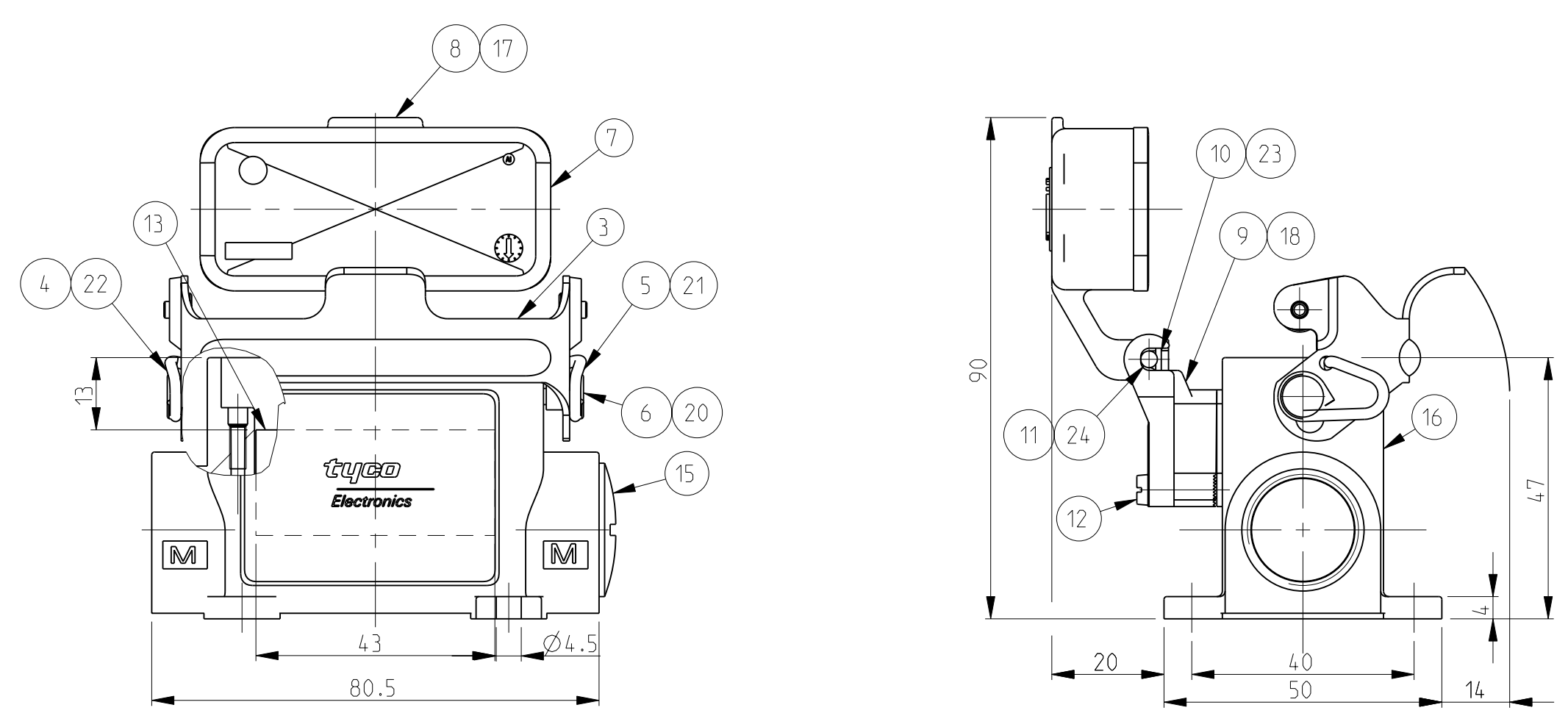

QTY	DESCRIPTION	MATERIAL	SURFACE	COLOR	ITEM NO	REMARKS
1	GROVED PIN	STAINLESS STEEL	BLANC		24	
1	LEAF SPRING	STAINLESS STEEL	BLANC		23	
1	CLIP SPRING RIGHT	STAINLESS STEEL	BLANC		22	
1	CLIP SPRING LEFT	STAINLESS STEEL	BLANC		21	
2	CLIP POSITIONER	STAINLESS STEEL	BLANC		20	
1	SIDE CLIP	STAINLESS STEEL	BLANC		19	
1	HINGE	ALUMINIUM	HART COAT	BLACK	18	
1	COVER	ALUMINIUM	HART COAT	BLACK	17	
1	Surface Mounted Housing-Side Entry	Aluminium	HART COAT	BLACK	16	
1	Blanking Piece With Sealing-Metric				15	
1	Surface Mounted Housing-Side Entry	ALUMINIUM		BLACK	14	
2	2 Insulating Tape	COROPLAST TYP 303		GREY	13	PVC-Soft
2	2 Cylinder Screw	STAINLESS STEEL	BLANC		12	M3x16
	1 GROVED PIN	STEEL	ZINC PLATED	BLUE	11	Di3x30
	1 LEAF SPRING	STEEL	ZINC PLATED	BLUE	10	
	1 HINGE	ALUMINIUM		GREY	9	
	1 COVER	ALUMINIUM		GREY	8	
1	1 PROFILE SEAL	Neoprene		Black	7	
2	2 CLIP POSITIONER	STEEL	ZINC PLATED	BLUE	6	
1	1 CLIP SPRING LEFT	STEEL	ZINC PLATED	BLUE	5	
1	1 CLIP SPRING RIGHT	STEEL	ZINC PLATED	BLUE	4	
1	1 SIDE CLIP	STEEL	ZINC PLATED	BLUE	3	
	1 Surface Mounted Housing-Side Entry	ALUMINIUM		GREY	2	
	1 Surface Mounted Housing-Side Entry	ALUMINIUM		GREY	1	

HA.10.SGD-LB.2.M20.Z  
 HA.10.SG-LB.2.M20.Z  
 HA-EMV.10.SG-LB.2.M20.G  
 HA-K.10.SGD-LB

DIMENSIONS:	TOLERANCES UNLESS OTHERWISE SPECIFIED:	DWN	3/3/2006	Tyco Electronics AMP GmbH 53757 Sankt Augustin (Germany)
mm	0.130 0.001 0.010 0.020 0.050 0.100 0.200 0.500 1.000 2.000 5.000 10.000	CHK	3/3/2006	
		APVD	3/3/2006	
		PRODUCT SPEC		
		APPLICATION SPEC		
MATERIAL	FINISH	WEIGHT	A   00779	SCALE 1:1 SHEET 1 OF 1 REV: B4
		CUSTOMER DRAWING	C=1106410	