

1-1103401-1 Product Details

[Share](#) [Print](#) [Email](#)

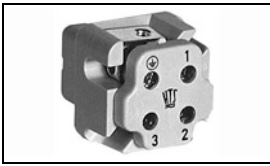

1-1103401-1

TE Internal Number: 1-1103401-1

Active

[View 3D PDF](#)

HTS Connectors and Accessories

Always EU RoHS/ELV Compliant (Statement of Compliance)

Product Highlights:

- HA.3 Series
- Insert
- Product Size = 1
- Contact Configuration = Screw Terminal
- Insert Style = Socket

[View all Features](#)

Quick Links

- ▶ [Pricing & Availability](#)
- ▶ [Search for Tooling](#)
- ▶ [Product Feature Selector](#)
- ▶ [Contact Us About This Product](#)

[Add to My Part List](#) [Request Sample](#) [Find Similar Products](#) [Buy Product](#)

Documentation & Additional Information

Product Drawings:

- [Female insert](#) (PDF, English)

Catalog Pages/Data Sheets:

- [HTS Heavy Duty Connectors catalogue](#) (PDF, English)

Product Specifications:

- None Available

Application Specifications:

- None Available

Instruction Sheets:

- None Available

CAD Files: [\(CAD Format & Compression Information\)](#)

- [2D Drawing](#) (DXF, Version C)
- [3D Model](#) (IGES, Version C)
- [3D Model](#) (STEP, Version C)

[List all Documents](#)

Additional Information:

- [Product Line Information](#)

Related Products:

- [Tooling](#)

Product Features (Please use the Product Drawing for all design activity)

Product Type Features:

- Product Type = Insert
- Product Size = 1
- Gender = Female

Electrical Characteristics:

- Power Circuit Voltage (V) = 250
- Power Circuit Current (A) = 10
- Pollution Degree = 3

Body Features:

- Insert Style = Socket

Contact Features:

- Contact Configuration = Screw Terminal
- Number of Poles = 3+PE
- Contact Plating, Mating Area, Material = Hard Silver

Industry Standards:

- [RoHS/ELV Compliance](#) = RoHS compliant, ELV compliant
- [Lead Free Solder Processes](#) = Not relevant for lead free process
- [RoHS/ELV Compliance History](#) = Always was RoHS compliant

Packaging Features:

- Packaging Method = Loose Piece
- Packaging Quantity = 10

Other:

- Series = HA.3
- Brand = HTS

Corporate Information

- [About TE](#)
- [Investors](#)
- [News Room](#)
- [Supplier Portal](#)
- [Careers](#)
- [Terms & Conditions](#)
- [Privacy Policy](#)

Quick Links

- [Distributor Inventory](#)
- [Product Cross Reference](#)
- [Documents & Drawings](#)
- [Product Compliance Support Center](#)
- [Site Map](#)

Customer Support

- [Email or Chat With Us](#)
- [Find a Phone Number](#)
- [Knowledge Base](#)
- [Manage Your Account](#)

Keep Me Informed

LOC	DIST	REVISIONS ÄNDERUNGEN				DATE	DWN	APVD
AI	-	P	LTR	DESCRIPTION BESCHREIBUNG				
PROJECT NR.	HA.3/4	C1		PRINTING CORRECTED ECR-06-021058	01.09.2006	SR	SM	

CONTACT ARRANGEMENT
VIEW FROM CONNECTING SIDE

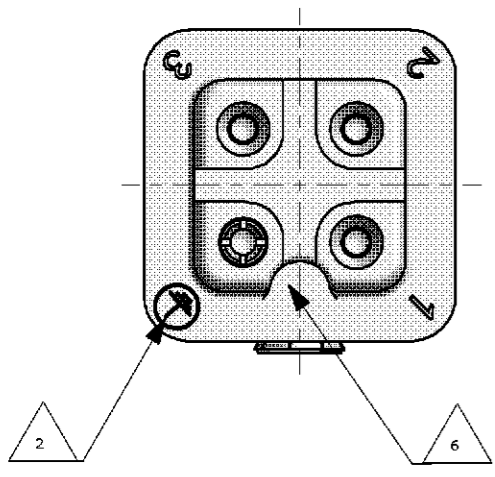

LATERAL PRINT
PN 1-1

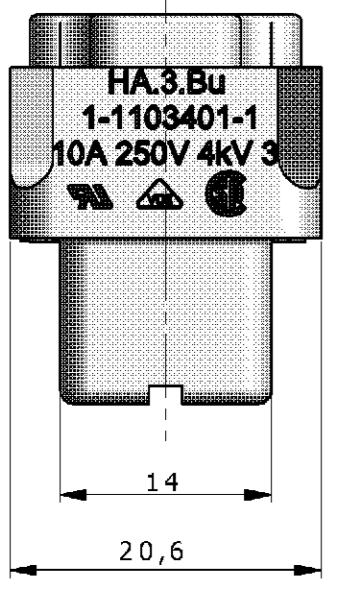

LATERAL PRINT
PN 0-1

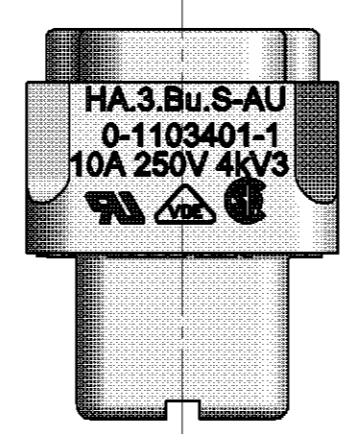

LATERAL PRINT
PN 0-3

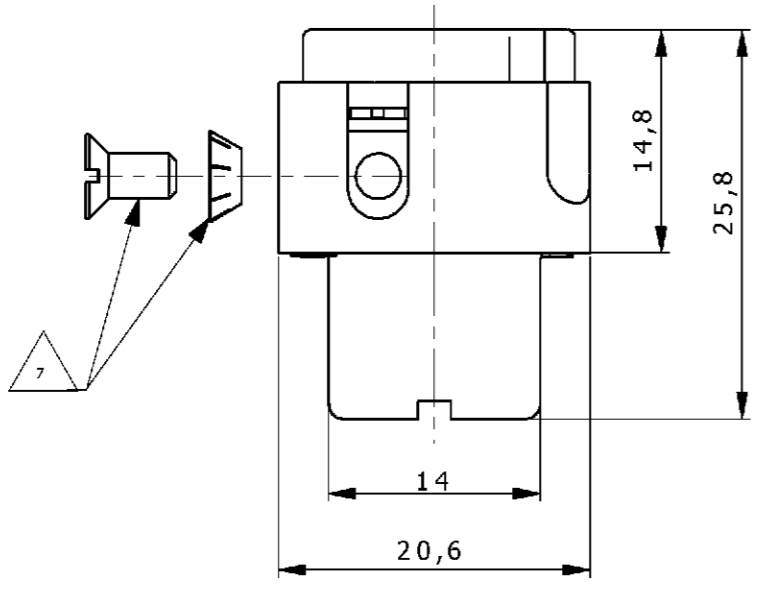
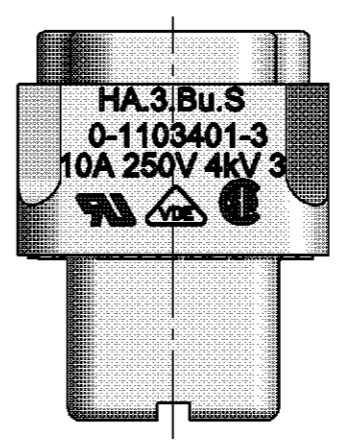

NOTES

- 1 CONTACT: 1 TO 3
SUITABLE SCREW CONTACTS: SERIES HA.3
OUTER DIMENSIONS OF INSULATION: MAX. Ø3,4 MM
- 2 GROUNDING CONTACT:
SUITABLE SCREW CONTACTS: SERIES HA.3
OUTER DIMENSIONS OF INSULATION: MAX. Ø3,4 MM
- 3 SUITABLE HOOD SIZE 1: SERIES HA; HD; EMV AND HIP
- 4 SUITABLE INSERTION AND EXTRACTION TOOL:
SCREWDRIVER 2,0x65
- 5 STANDARDS:
DIN EN 61984; DIN EN 60664-1
- 6 POLARIZATION RIPS
- 7 POS. 8 AND POS.9 PACKED SEPARATE IN POLY BAG
- 8 AUTHORIZATION: UL; CSA; VDE; SEV
- 9 PACKAGING:
10 SETS IN A CARTON, PRE-MOUNTED
- 10 PACKAGING:
200 SETS IN A CANN-BAN BOX

CONTACT ARRANGEMENT
VIEW FROM TERMINATION SIDE

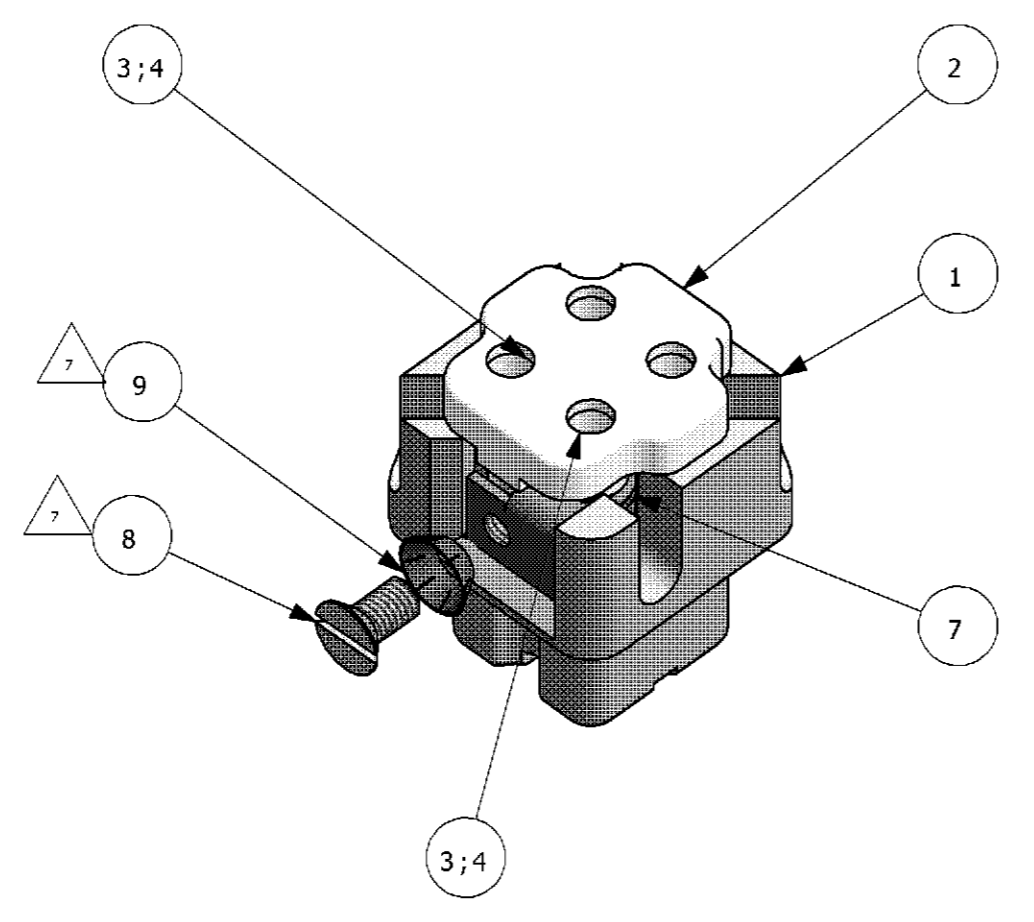
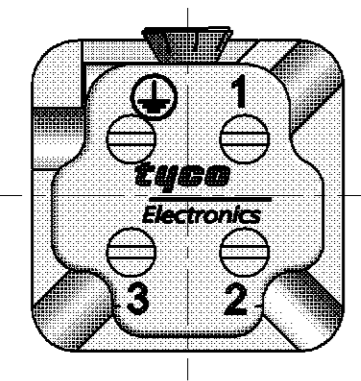

QTY	QTY	QTY	QTY	DESCRIPTION	MATERIAL	COLOR	SURFACE	ITEM	NOTES
1	1	1		SPRING WASHER	SEEL		ZINK PLATED	9	V3.2
1	1	1		SLOTTED OUTER FLAT HEAD SCREW	SEEL		ZINK PLATED	8	M3x6
4	4	4	4	SLOTTED CHEESE HEAD SCREW	BRASS		NICKEL PLATED	7	M3x5.5
1				EARTING CONTACT PIN WITH ANGLE	BRASS		SILVER PLATED	6	
1		1	1	EARTING CONTACT SOCKET WITH ANGLE	BRASS		GOLD PLATED	5	
3				CONTACT SOCKET	BRASS		GOLD PLATED	4	
3		3	3	CONTACT SOCKET	BRASS		SILVER PLATED	3	
1	1	1	1	COVER	PC	BEIGE		2	
1	1	1	1	FEMALE INSERT	PC	BEIGE		1	
QTY	QTY	QTY	QTY	DESCRIPTION	MATERIAL	COLOR	SURFACE	ITEM	NOTES
0-3	0-2	0-1	1-1						
				HA.3.Bu.S					
				HA.3.Bu.S-AU					
				HA.3.Bu.S-KM					
				HA.3.Bu.S					

THIS DRAWING IS A CONTROLLED DOCUMENT FOR AMP INCORPORATED. IT IS SUBJECT TO CHANGE AND THE CONTROLLING ENGINEERING ORGANIZATION SHOULD BE CONTACTED FOR THE LATEST REVISION. DIESSES ZEICHNUNGS-DOKUMENT WIRD DURCH AMP INCORPORATED KONTROLLIERT. ÄNDERUNGEN, DIE DEM TECHNISCHEN FORTSCHRITT ÜBEREN, SIND VORZUHALTEN. DEN VEREINBARTETZTEN ANÄNDERUNGEN BEFOLGEN SIE AMP ANFANG.

DIMENSIONS:
DIMENSIONEN:
m/m

TOLERANCES UNLESS OTHERWISE SPECIFIED:
ALLGEMEIN TOLERANZEN

m. ISO 8013 - m H-E
m. ISO 2768 - m H-E
m. DIN 16981 - 140

0 PLC #
1 PLC #
2 PLC #
3 PLC #
ANGLES / WINKEL #

MATERIAL FINISH / OBERFLÄCHE / FARBE

WEIGHT / GEWICHT 0,013 KG

DWN SCHNEIDER 09.05.2006
CHK KRAMER 24.09.1999
ARVD T.SCHNURPFEL 10.04.2006

NAME FEMALE INSERT
HA.3.BU.S

PRODUCT SPEC. 108-74055
APPLICATION SPEC. 114-74056

SIZE A2 CAGE CODE 00779 DRAWING NO. 1103401

RESTRICTED TO NUR FÜR

CUSTOMER DRAWING / KUNDENZEICHNUNG SCALE 1:1 SHEET 1 OF 1 REV. C1

Tyco Electronics AMP GmbH
D - 53819 Neunkirchen