

THIS DRAWING IS UNPUBLISHED. RELEASED FOR PUBLICATION NOV ,2005.
 © COPYRIGHT 2005 BY TYCO ELECTRONICS CORPORATION. ALL RIGHTS RESERVED.

LOC	DIST	REVISIONS					
E	B	P	LTR	DESCRIPTION	DATE	DWN	APVD
		C		ECR-05-016219	23NOV05	JMS	FWK

- NOTES:**
- ① PACK IN ACCORDANCE WITH AMP SPEC 107-3275
 - ② 100 TRAY PACK IN ACCORDANCE WITH AMP SPEC 107-3275
 - ③ Ag PLATING
 - ④ THIS ITEM MUST BE WHITE
 - 5 HAND TOOL : 9-1478240-0
 - 6 DIE SET : 9-1478245-0
 - 7 ELECTRICAL CHARACTERISTICS
 FREQUENCY RANGE: DC - 2 GHz
 NOMINAL IMPEDANCE: 75 Ohm
 INSULATION RESISTANCE: 5000 MOhm
 WORKING VOLTAGE: 500 Volts RMS at Sea Level
 DIELECTRIC WITHSTAND VOLTAGE: 1500 Volts RMS Max
 CONTACT RESISTANCE:
 CENTRE CONTACT: 1.50 mOhm Max
 OUTER CONTACT: 0.20 mOhm Max
 VSWR @ 2GHz: 1.20:1 Max
 INSERTION LOSS dB @ x 2 GHz: 0.20 Max
 - 8 MECHANICAL CHARACTERISTICS
 COUPLING RETENTION FORCE: 445N Min
 CABLE RETENTION FORCE: 85N Min
 DURABILITY: 500 Cycles Min
 - 9 ENVIRONMENTAL CHARACTERISTICS
 OPERATING TEMPERATURE: -65 to +165 DegC

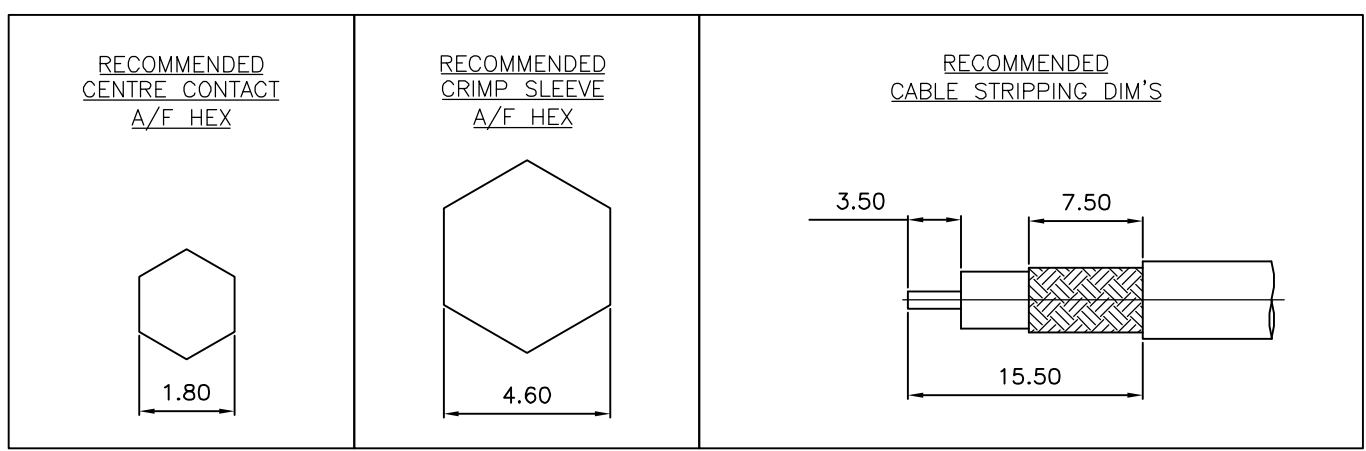
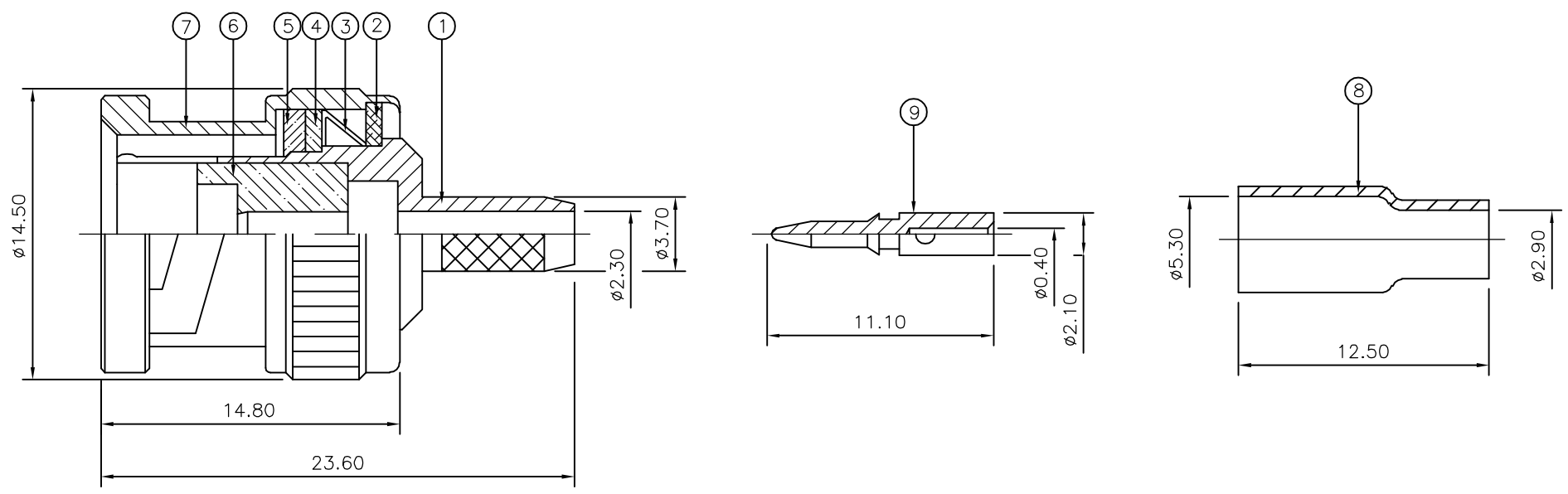

QTY	QTY	MATERIAL	DESCRIPTION	ITEM
1	1	BRASS	CONTACT	9
1	1	BRASS	FERRULE	8
1	1	BRASS	SHELL	7
1	1	PTFE	INSULATION	6
1	1	SILICON RUBBER	GASKET	5
1	1	BRASS	WASHER	4
1	1	SPRING STEEL	SPRING	3
1	1	BRASS	WASHER	2
1	1	BRASS	BODY	1
6--0	1--0	MATERIAL	DESCRIPTION	ITEM

THIS DRAWING IS A CONTROLLED DOCUMENT.		DWN J.SANDWELL 23NOV05	Tyco Electronics Corporation Bideford EX39 4HE	
DIMENSIONS: mm		CHK S.PARLOW 23NOV05		
TOLERANCES UNLESS OTHERWISE SPECIFIED:		APVD F.WHEELER-KING 23NOV05	NAME BNC STRAIGHT PLUG CRIMP 75 OHM RG179B/U, 187A/U, URM111	
0 PLC ± -		PRODUCT SPEC 108-3435	SIZE A3	
1 PLC ± -		APPLICATION SPEC 411-3247	CAGE CODE 00779	DRAWING NO C-1337432
2 PLC ± -		WEIGHT -	RESTRICTED TO -	
3 PLC ± -		MATERIAL SEE TABLE	SCALE NTS	
4 PLC ± -			SHEET 1 OF 1	
ANGLES ± -		CUSTOMER DRAWING		REV C
FINISH -				