

LOC	DIST	REV	DESCRIPTION	DATE	BY	APP'D
E	B	P	TR			
		A	RELEASE FOR PRODUCTION	5-9-01	RG	FWK

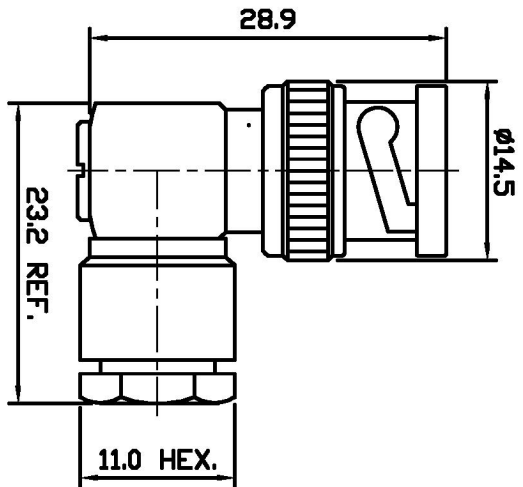

▲ SUPPLIED SEMI-ASSEMBLED (PACK CONTAINS LOOSE PIECES)
 VIEW SHOWS ASSEMBLED CONNECTOR (CABLE OMITTED)
 FOR CABLE TO CONNECTOR ASSEMBLY GUIDANCE
 REFER TO TYCO INSTRUCTION SHEET IS 411 - 3266

ALL DIMENSIONS ARE NOMINAL. FOR REFERENCE ONLY.

DIE SET PART NUMBER	N/A
HANDTOOL PART NUMBER	N/A
FOR USE ON CABLES	RG59B/U, 62A/U, RG140/U
CONNECTOR PLATING DETAIL	SILVER
CONTACT PLATING DETAIL	SILVER
DIELECTRIC MATERIAL	PTFE
GASKET MATERIAL	WHITE SILICONE RUBBER

THIS DRAWING IS A CONTROLLED DOCUMENT.	
DIMENSIONS:	TOLERANCES UNLESS OTHERWISE SPECIFIED:
MM	± .1
0 PLG	± .1
2 PLG	± .1
4 PLG	± .1
ANGLES	± .1
FINISH	± .1

DATE	BY	DESCRIPTION	PART NUMBER
5-9-01	R. GOODALL	BAG	1-1478129-0
5-9-01	E. W-KING	PACK TYPE	
5-9-01	E. W-KING	DESCRIPTION	
108-3435		PRODUCT SPEC	
		APPLICATION SPEC	
		WEIGHT	
		CUSTOMER DRAWING	

Tyco
 Tyco Electronics Corporation
 Stamford, Middlesex, HA7 4RS

SIZE: A3
 CASE CODE: 00779
 DRAWING NO: 1478129

SCALE: NTS
 SHEET: 1 OF 1
 REV: A