

THIS DRAWING IS UNPUBLISHED.

RELEASED FOR PUBLICATION APR ,2003.

LOC GP DIST 00

REVISIONS

© COPYRIGHT 2003 By -

ALL RIGHTS RESERVED.

P	LTR	DESCRIPTION	DATE	DWN	APVD
	K	REVISED PER ECO-15-011829	09MAR2016	AP	DG

- 1 MATERIAL
HOUSING : THERMOPLASTIC, UL94V-0, BLACK
CONTACTS : PHOSPHOR BRONZE
SHELL : STEEL
SCREW : BRASS.
BOARD LOCK : BRASS.
SCREW OF TORQUE : 5 Kg-cm MAX.
- 2 FINISH
CONTACT : 15µ" MIN.GOLD PLATING ON CONTACT AREA
100µ" MIN. TIN PLATING ON SOLDER TAILS
50µ" MIN. NICKEL UNDERPLATED OVERALL
SHELL : 100µ" MIN NICKEL PLATING
SCREW : 50µ" MIN. NICKEL PLATING.
BOARD LOCK : 50µ" MIN. NICKEL PLATING.
- 3 CHARACTERISTICS
CURRENT RATING : 3A
INSULATION RESISTANCE : 1000MOHMS MIN, 500VDC FOR 2MINS.
TEMPERATURE RATING : -55DEGC ~ +105DEGC
VOLTAGE RATING : 250VDC

4 OBSOLETE PARTS: OBSOLETE CIS STREAMLINING PER D.RENAUD/D.SINISI.

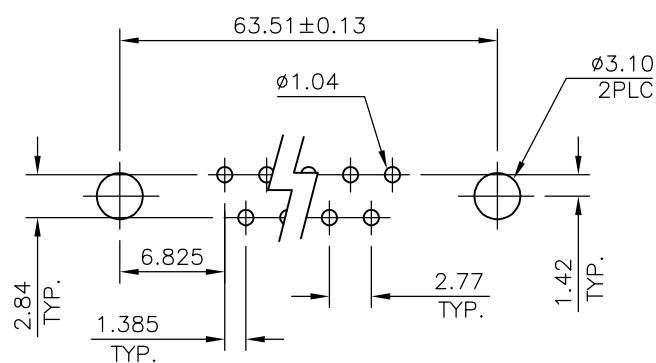
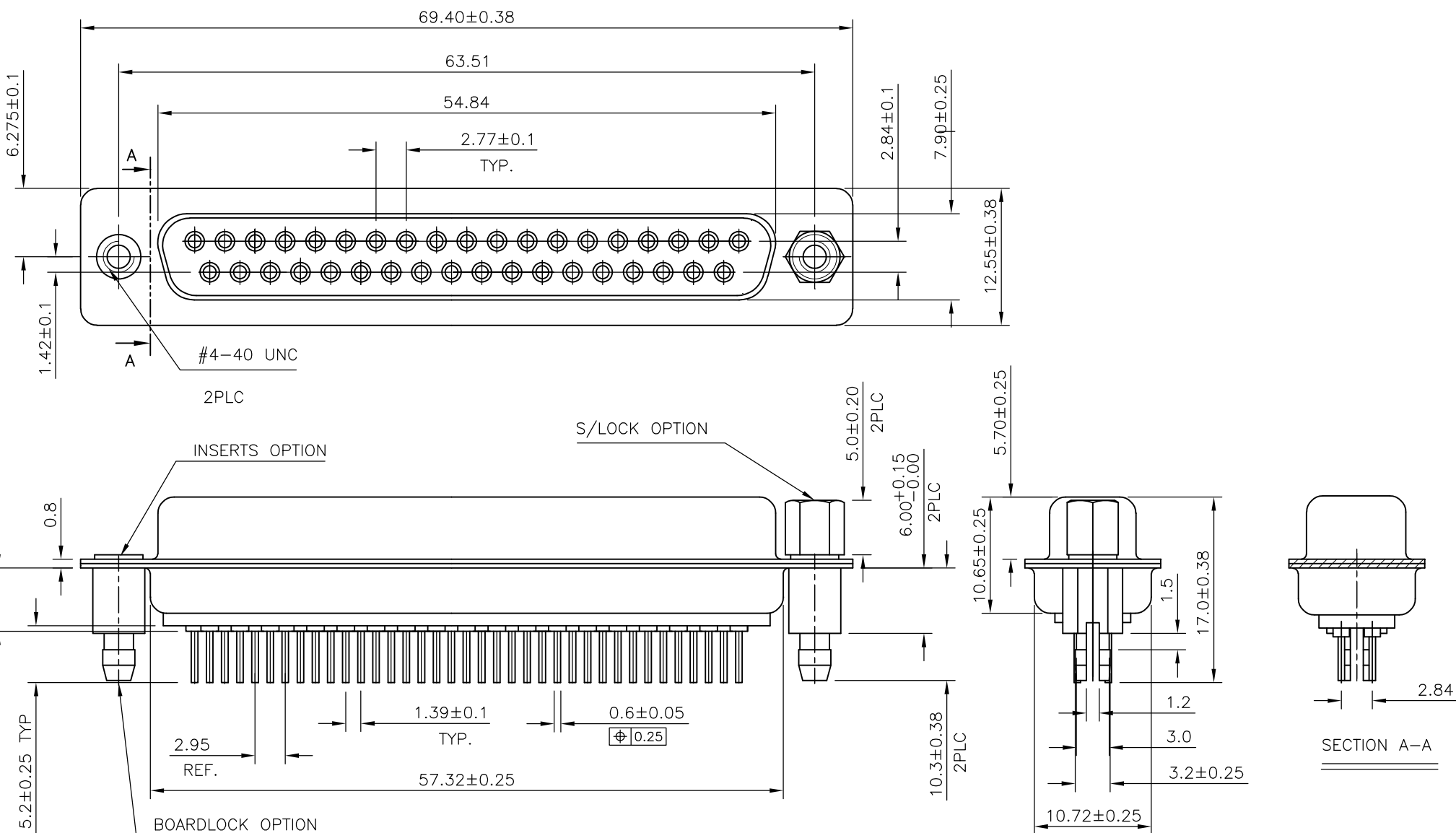

4	OBSOLETE	37W D SKT WITH B/L & M3 S/LOCK 15µ" GOLD	4-1634225-2
		37W D SKT WITH B/L & 4-40 S/LOCK 15µ" GOLD	3-1634225-2
4	OBSOLETE	37W D SKT WITH B/L & M3 INSERTS 15µ" GOLD	2-1634225-2
4	OBSOLETE	37W D SKT WITH B/L & 4-40 INSERTS 15µ" GOLD	1-1634225-2
		DESCRIPTION	TE PART NO.

THIS DRAWING IS A CONTROLLED DOCUMENT.		DWN J.SANDWELL 10APR03	TE Connectivity D-SUB HD20, VERTICAL, 37P SKT CONNECTOR	
DIMENSIONS: mm		CHK R.DYER 10APR03		
TOLERANCES UNLESS OTHERWISE SPECIFIED:		APVD F.WHEELER-KING 10APR03	NAME	
0 PLC ± -		PRODUCT SPEC	SIZE	
1 PLC ± 0.25		APPLICATION SPEC	CAGE CODE	
2 PLC ± 0.15			DRAWING NO	
3 PLC ± -			RESTRICTED TO	
4 PLC ± -			A3 00779 C-1634225	
ANGLES ± -		WEIGHT -	SCALE 2:1	
FINISH -		CUSTOMER DRAWING		SHEET 1 OF 2
				REV K

THIS DRAWING IS UNPUBLISHED.

RELEASED FOR PUBLICATION APR , 2003.

© COPYRIGHT 2003 By -

ALL RIGHTS RESERVED.

LOC	DIST	REVISIONS					
GP	00	P	LTR	DESCRIPTION	DATE	DWN	APVD
		-		SEE SHEET 1	-	-	-

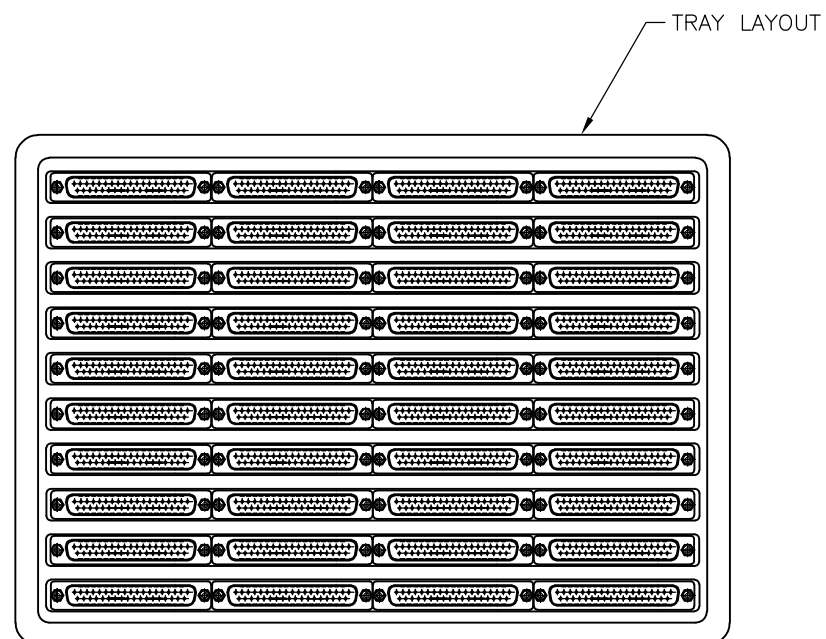
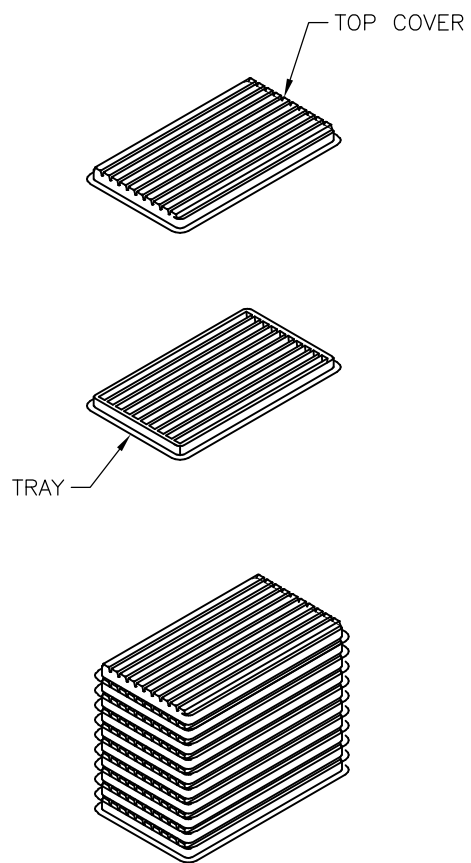

- MATERIAL
- 1 TRAY: PVC
 - 2 SHIPPING CARTON: CORRUGATED FIBERBOARD
- DIMENSIONS
- 1 TRAY: L=310, W=230, H=21
 - 2 SHIPPING CARTON: L=330, W=245, H=160
- QUANTITY
- 40 PCS/TRAY
 - 10 TRAY/SHIPPING CARTON

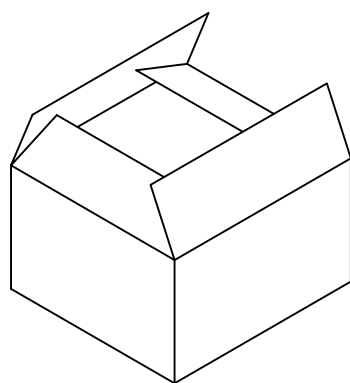

THIS DRAWING IS A CONTROLLED DOCUMENT.		DWN	J. SANDWELL	10APR03	STE TE Connectivity		
DIMENSIONS: mm		CHK	R. DYER	10APR03			
TOLERANCES UNLESS OTHERWISE SPECIFIED:		APVD	F. WHEELER-KING	10APR03	NAME		
0 PLC ± -		PRODUCT SPEC		D-SUB HD20, VERTICAL, 37P SKT CONNECTOR			
1 PLC ± 0.25		APPLICATION SPEC		-			
2 PLC ± 0.15		SIZE	A3	CAGE CODE	00779	DRAWING NO	C=1634225
3 PLC ± -		WEIGHT		-		RESTRICTED TO	
4 PLC ± -		CUSTOMER DRAWING		SCALE		2:1	
ANGLES ± -		FINISH		-		SHEET	
MATERIAL		-		-		2 OF 2	
-		-		-		REV	
-		-		-		K	