



**Have a Question?**  
 Chat with a Product  
 Information Specialist

What can we help you find?

[Products](#) [Industries](#) [Resources](#) [About TE](#) [My Account](#) [Innovation](#) [Support Center](#)

**1-200874-2 Product Details**

[Share](#) [Print](#) [Email](#)



**1-200874-2**

TE Internal Number: 1-200874-2

Active

[View 3D PDF](#)

**M Series Connectors**

Always EU RoHS/ELV Compliant (Statement of Compliance)

**Product Highlights:**

- Product Series = M Series
- Hardware
- Hardware Type = Jackscrew Kit
- Jackscrew Type = Fixed
- Jackscrew Style = Short

[View all Features](#)

**Quick Links**

- ▶ [Pricing & Availability](#)
- ▶ [Search for Tooling](#)
- ▶ [Product Feature Selector](#)
- ▶ [Contact Us About This Product](#)

[Add to My Part List](#) [Request Sample](#) [Find Similar Products](#) [Buy Product](#)

**Documentation & Additional Information**

**Product Drawings:**

- [JACKSCREW KIT, UNASSEMBLED, STUD, FIXED, M SERIES](#) (PDF, English)

**Catalog Pages/Data Sheets:**

- [M\\_SERIES\\_PIN\\_AND\\_SOCKET\\_CONNECTORS](#) (PDF, English)

**Product Specifications:**

- None Available

**Application Specifications:**

- None Available

**Instruction Sheets:**

- None Available

**CAD Files:** ([CAD Format & Compression Information](#))

- [2D Drawing](#) (DXF, Version Z)
- [3D Model](#) (IGES, Version Z)
- [3D Model](#) (STEP, Version Z)

[List all Documents](#)

**Additional Information:**

- [Product Line Information](#)

**Related Products:**

- [Tooling](#)

**Product Features (Please use the Product Drawing for all design activity)**

**Product Type Features:**

- Product Series = M Series
- Product Type = Hardware
- Jackscrew Type = Fixed
- Thread Size = 4-40, 6-32 [M3.5 x 0.6]
- Strain Relief = Without
- Sealed = No

**Mechanical Attachment:**

- Hardware Type = Jackscrew Kit
- [Mounting Hardware](#) = Nuts and Lockwashers

**Dimensions:**

- Length (X-Axis) (mm [in]) = 20.62 [0.812]
- Width (Z-Axis) (mm [in]) = 5.60 [0.220]
- Profile Height (Y-Axis) (mm [in]) = 5.60 [0.220]

**Body Features:**

- Jackscrew Style = Short
- Thread Lead Type = Double
- Mating Retention = Without
- Jackscrew Material = Stainless Steel

**Housing Features:**

- Mating Alignment = Without

**Industry Standards:**

- [RoHS/ELV Compliance](#) = RoHS compliant, ELV compliant
- [Lead Free Solder Processes](#) = Not relevant for lead free process
- [RoHS/ELV Compliance History](#) = Always was RoHS compliant

**Conditions for Usage:**

- For Use With = Mate with Any Turnable Jackscrew Cylinder

**Packaging Features:**

- Packaging Method = Bag
- Packaging Quantity = 100

**Other:**

- Brand = AMP
- Comment = Two required.

**Corporate Information**

- [About TE](#)
- [Investors](#)
- [News Room](#)

**Quick Links**

- [Distributor Inventory](#)
- [Product Cross Reference](#)
- [Documents & Drawings](#)

**Customer Support**

- [Email or Chat With Us](#)
- [Find a Phone Number](#)
- [Knowledge Base](#)

THIS DRAWING IS UNPUBLISHED. RELEASED FOR PUBLICATION  
 © COPYRIGHT BY TYCO ELECTRONICS CORPORATION. ALL INTERNATIONAL RIGHTS RESERVED.

LOC	DIST	REVISIONS					
FT	0	P	LTR	DESCRIPTION	DATE	DWN	APVD
		AG		REVISED PER ECO-10-021995	12JAN11	HMR	MG

 ZINC PLATE

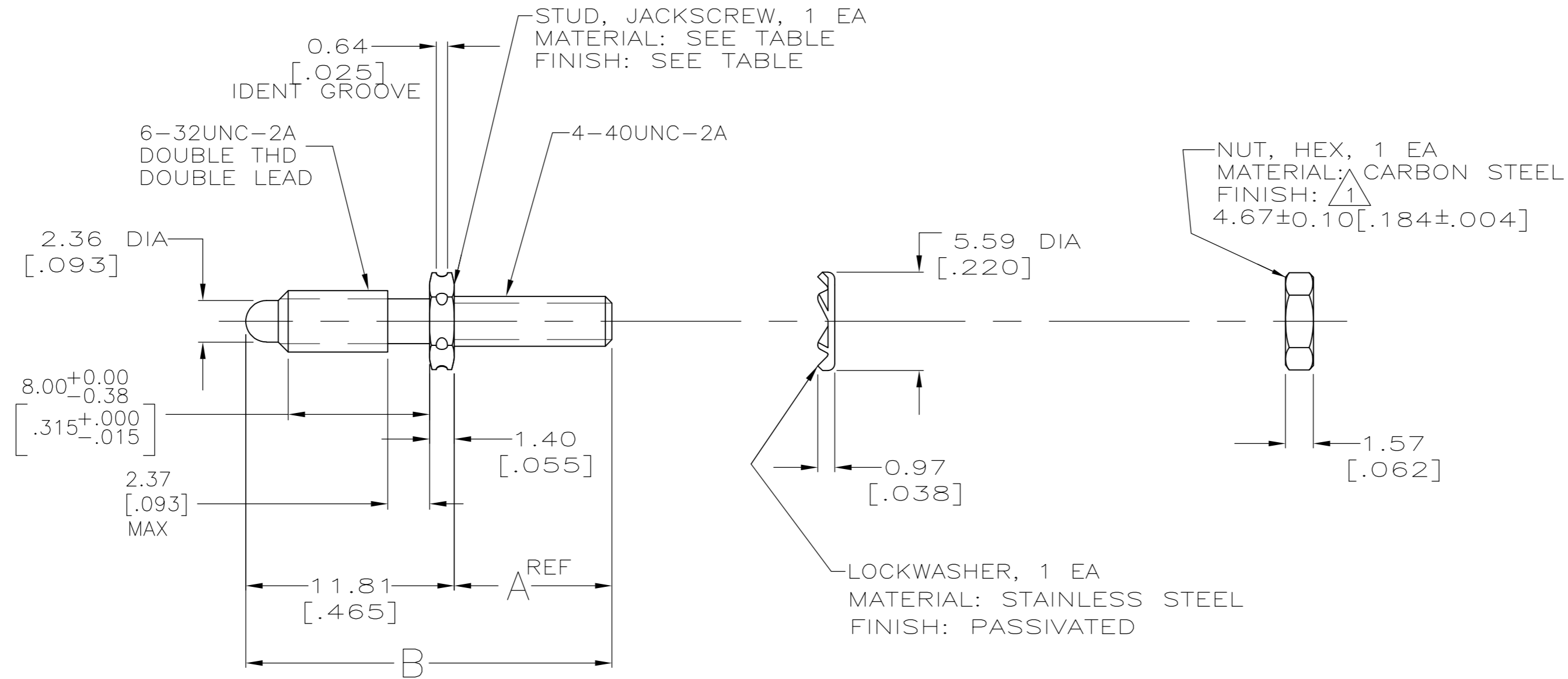

	-	STAINLESS STL	20.62 [.812]	8.81 [.347]	1-200874-2
	-	STAINLESS STL	23.80 [.937]	11.99 [.472]	200874-3
SUPERCEDED TO 200874-1	ZINC	CARBON STEEL	20.62 [.812]	8.81 [.347]	200874-2
SUPERCEDED TO 1-200874-2	-	STAINLESS STL	20.62 [.812]	8.81 [.347]	200874-1
FINISH	MATERIAL	B	A	PART NUMBER	
JACKSCREW STUD					

THIS DRAWING IS A CONTROLLED DOCUMENT.		DWN	02/25/92	Tyco Electronics Corporation	
		CHK	2-28-92	Harrisburg, PA 17105-3608	
		APVD	-	NAME	
		PRODUCT SPEC	-	JACKSCREW KIT, UNASSEMBLED, STUD, FIXED, M SERIES	
		APPLICATION SPEC	-	SIZE	RESTRICTED TO
		WEIGHT	-	A2	-
MATERIAL		FINISH	SEE CALLOUT	CAGE CODE	DRAWING NO
SEE CALLOUT		SEE CALLOUT	SEE CALLOUT	00779	C=200874
CUSTOMER DRAWING			SCALE	SHEET	REV
			4:1	1 OF 1	AG