

LOC	DIST	REVISIONS					
AF	50	P	LTR	DESCRIPTION	DATE	DWN	APVD
		G1		REVISED PER ECR-15-002109	11FEB2015	NK	DC

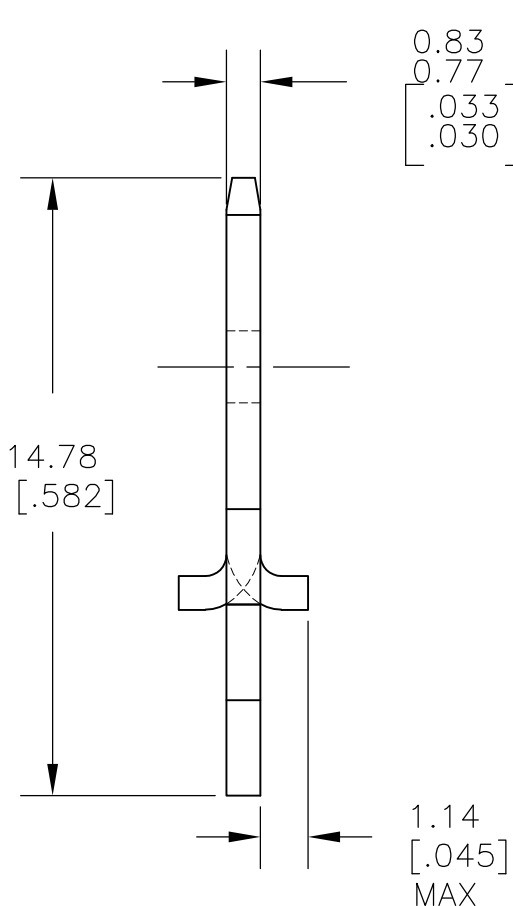

- 1 CONTINUOUS STRIP ON REELS.
- △ 2 TIN PLATE 0.00381 [.000150] MIN OVER 0.00254 [.000100] MIN THK COPPER OR TIN PLATE 0.00381 [.000150] MIN OVER 0.00127 [.000050] MIN THK NICKEL.
- △ 3 REELED WITH INTERLEAVE PAPER

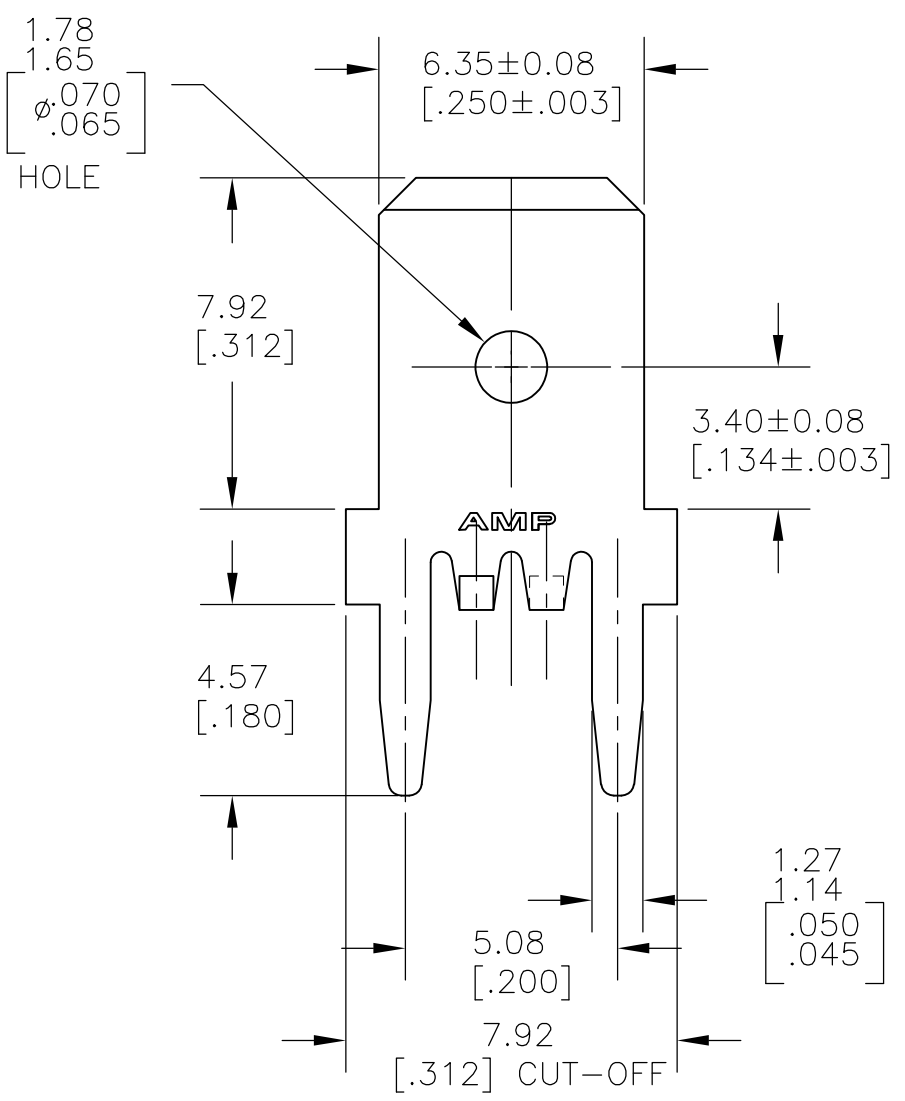
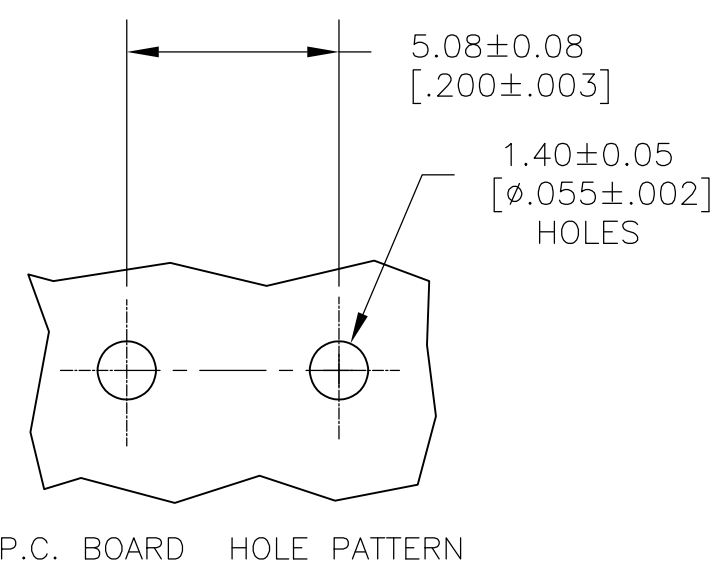

ACC. TO TE SPEC. 107-3 FIG. 318	△ 3 1217136-3
ACC. TO TE SPEC. 107-3 FIG. 918	1217136-2
ACC. TO TE SPEC. 107-3 FIG. 318	1217136-1
REELING	PART NO.

THIS DRAWING IS A CONTROLLED DOCUMENT.		DWN JR RUTH 28MAR01	STE TE Connectivity			
DIMENSIONS: mm[INCHES]		CHK MS FEHER 28MAR01				
TOLERANCES UNLESS OTHERWISE SPECIFIED:		APVD N DEIBERT 28MAR01	NAME			
0 PLC ± - 1 PLC ± - 2 PLC ± 0.25 [.010] 3 PLC ± - 4 PLC ± - ANGLES ± -		PRODUCT SPEC	TAB, FASTON, P.C.BOARD 6.35 [.250]			
MATERIAL BRASS	FINISH △ 2	APPLICATION SPEC 114-2115	SIZE A3	CAGE CODE 00779	DRAWING NO C-1217136	RESTRICTED TO -
CUSTOMER DRAWING			SCALE 6:1	SHEET 1 OF 1	REV G1	