

THIS DRAWING IS UNPUBLISHED. RELEASED FOR PUBLICATION
 © COPYRIGHT BY TYCO ELECTRONICS CORPORATION. ALL INTERNATIONAL RIGHTS RESERVED.

LOC FT	DIST 0	REVISIONS			
P	LTR	DESCRIPTION	DATE	DWN	APVD
	D2	REVISED PER ECO-08-030621	13FEB09	HMR	CR

MATERIAL:
 HOUSING: THERMOPLASTIC POLYESTER, UL94V-0, BLACK
 LEVER: THERMOPLASTIC, UL94V-0, WHITE, UNLESS OTHERWISE NOTED.
 TERMINAL: BRIGHT ACID TIN OVER COPPER ALLOY

ELECTRICAL:
 MAXIMUM CURRENT: 10A
 OPERATING VOLTAGE: 150/300V (LIMITED RATINGS)
 WIRE RANGE: 16-22 STRANDED ONLY

ENVIRONMENTAL:
 MAX OPERATING TEMP: 130°C

- 1 MARKED WITH WHITE PERMANENT INK.
- 2 SUITABLE FOR STRANDED WIRE ONLY, 16-22 AWG. DO NOT USE FUSED OR TINNED WIRED

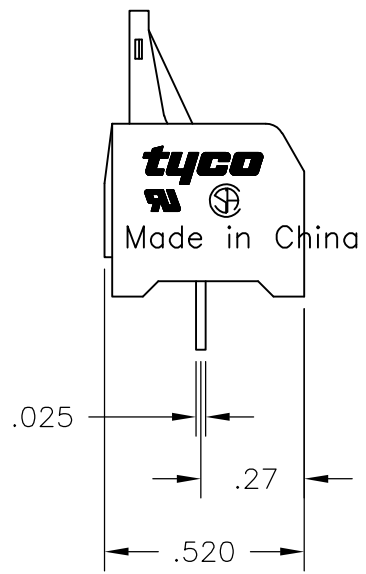
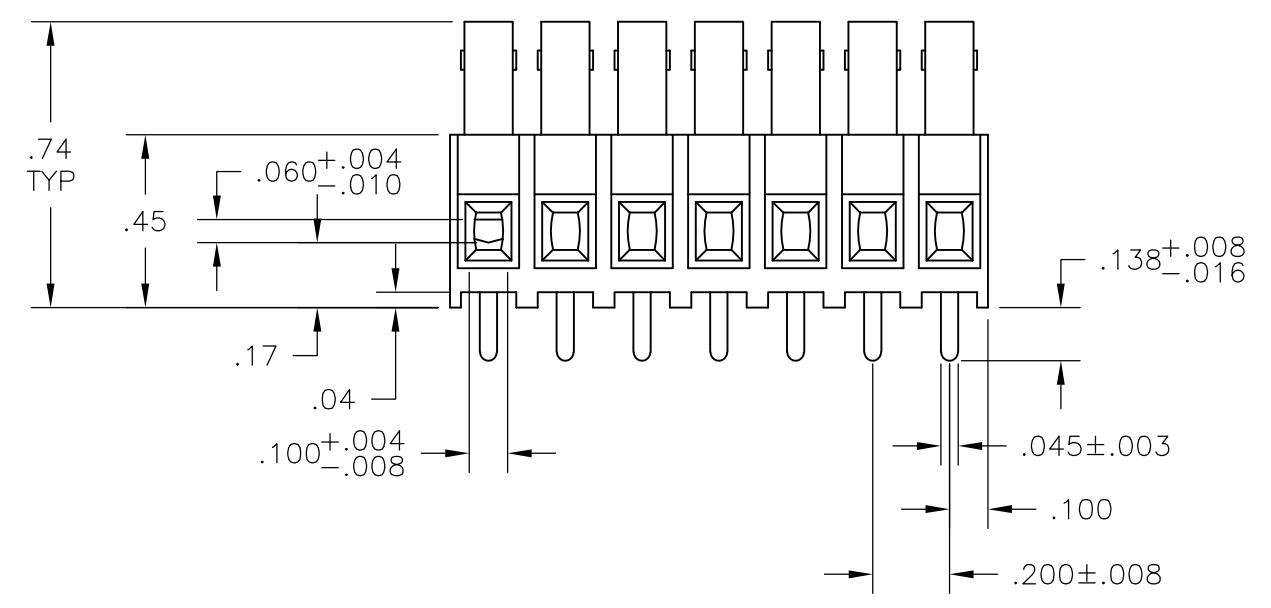
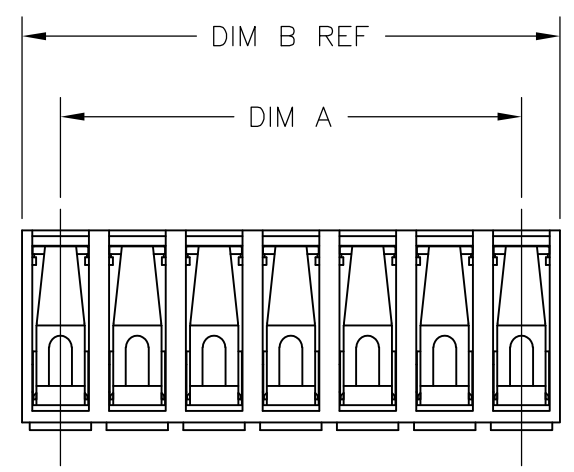

2SV-07 AS SHOWN

SEE FIGURE 1
 SEE FIGURE 1

SEE FIGURE

3.20	3.000	16	2SV-16	2-1437671-1
3.00	2.800	15	2SV-15	2-1437671-0
2.80	2.600	14	2SV-14	1-1437671-9
2.60	2.400	13	-	1-1437671-8
2.60	2.400	13	-	1-1437671-7
2.60	2.400	13	2SV-13	1-1437671-6
2.40	2.200	12	2SV-12	1-1437671-5
2.20	2.000	11	2SV-11	1-1437671-4
2.00	1.800	10	2SV-10	1-1437671-3
1.80	1.600	9	2SV-09	1-1437671-2
1.60	1.400	8	2SV-08	1-1437671-1
1.40	1.200	7	2SV-07	1-1437671-0
1.20	1.000	6	2SV-06	1437671-9
1.00	.800	5	2SV-05	1437671-7
.80	.600	4	2SV-04	1437671-6
.60	.400	3	2SV-03	1437671-4
.40	.200	2	-	1437671-2
.40	.200	2	2SV-02	1437671-1

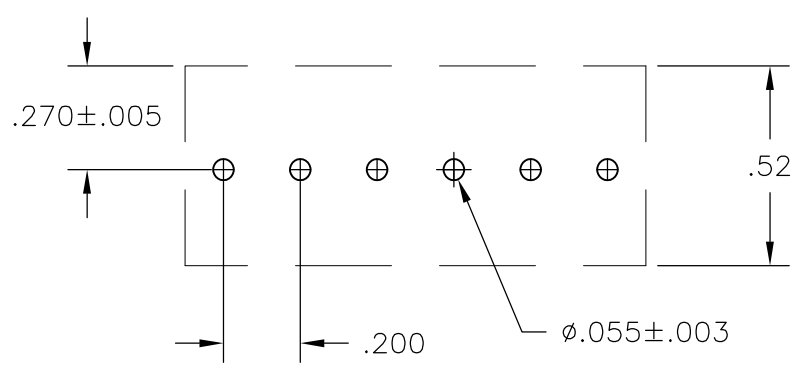

RECOMMENDED BOARD LAYOUT

THIS DRAWING IS A CONTROLLED DOCUMENT.		DWN S SCHLEGEL 14JUN02	Tyco Electronics Corporation Harrisburg, PA 17105-3608		
DIMENSIONS: INCHES	TOLERANCES UNLESS OTHERWISE SPECIFIED:	CHK C RICHARD 1/22/03	Tyco Electronics		
		APVD C RICHARD 1/22/03	2SV 5.08mm SCREWLESS		
MATERIAL	FINISH	PRODUCT SPEC	NAME		
		APPLICATION SPEC	SIZE CAGE CODE DRAWING NO RESTRICTED TO		
-	-	WEIGHT	A3	00779	C-1437671-1
CUSTOMER DRAWING		SCALE	NTS	SHEET	1 OF 2
		REV	D2		

THIS DRAWING IS UNPUBLISHED.

RELEASED FOR PUBLICATION

-. -. .

© COPYRIGHT - BY TYCO ELECTRONICS CORPORATION.

ALL INTERNATIONAL RIGHTS RESERVED.

LOC FT DIST 0

REVISIONS

P	LTR	DESCRIPTION	DATE	DWN	APVD
-	-	SEE SHEET 1	-	-	-

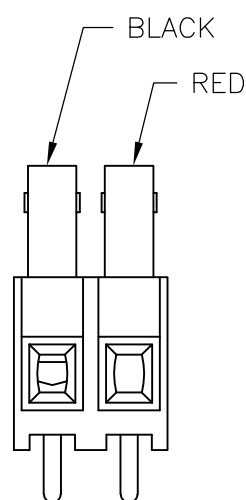

1437671-2

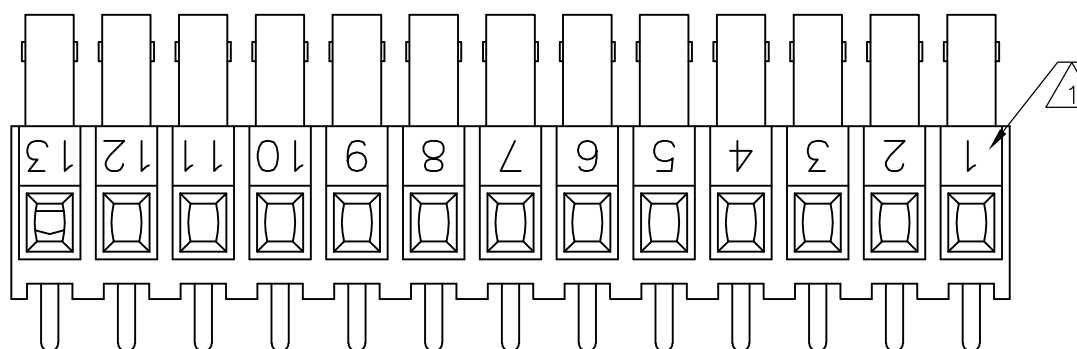

1-1437671-7

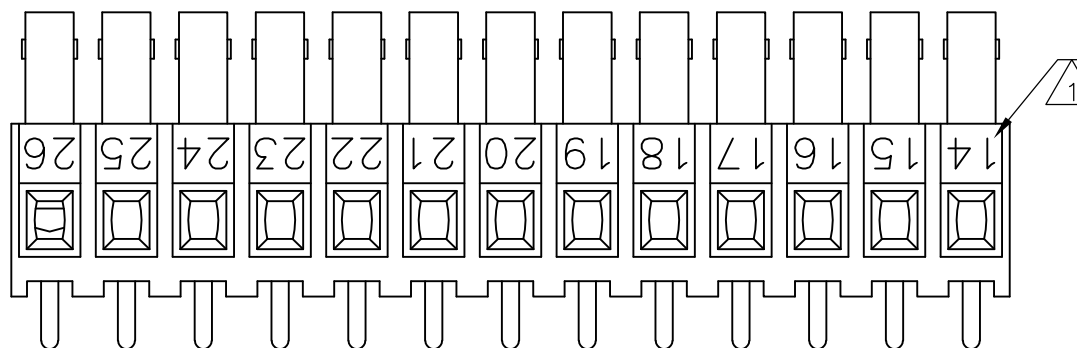

1-1437671-8

THIS DRAWING IS A CONTROLLED DOCUMENT.

DWN S SCHLEGEL 14JUN02

CHK C RICHARD 1/22/03

APVD C RICHARD 1/22/03

PRODUCT SPEC

APPLICATION SPEC

WEIGHT -

CUSTOMER DRAWING



Tyco Electronics Corporation
Harrisburg, PA 17105-3608

NAME
2SV 5.08mm
SCREWLESS

SIZE	CAGE CODE	DRAWING NO	RESTRICTED TO
A3	00779	C-1437671-1	-

DIMENSIONS:
INCHES

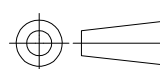

TOLERANCES UNLESS OTHERWISE SPECIFIED:

0 PLC	± -
1 PLC	± -
2 PLC	± .01
3 PLC	± .010
4 PLC	± -
ANGLES	± -
FINISH	-

MATERIAL -

FINISH -

SCALE	SHEET	REV
NTS	2 OF 2	D2