

4

3

2

1

THIS DRAWING IS UNPUBLISHED. RELEASED FOR PUBLICATION 20
 © COPYRIGHT 20 BY TYCO ELECTRONICS CORPORATION. ALL RIGHTS RESERVED.

LOC	DIST	REVISIONS					
FT	0	P	LTR	DESCRIPTION	DATE	DWN	APVD
			A	RELEASED EC 0G3B-0326-03	18JUL2003	SW	HW
			B	REVISED EC 0G3B-0990-04	27OCT2004	SW	HW
			C	REVISED ECO-06-010742	23MAY2006	SW	DC

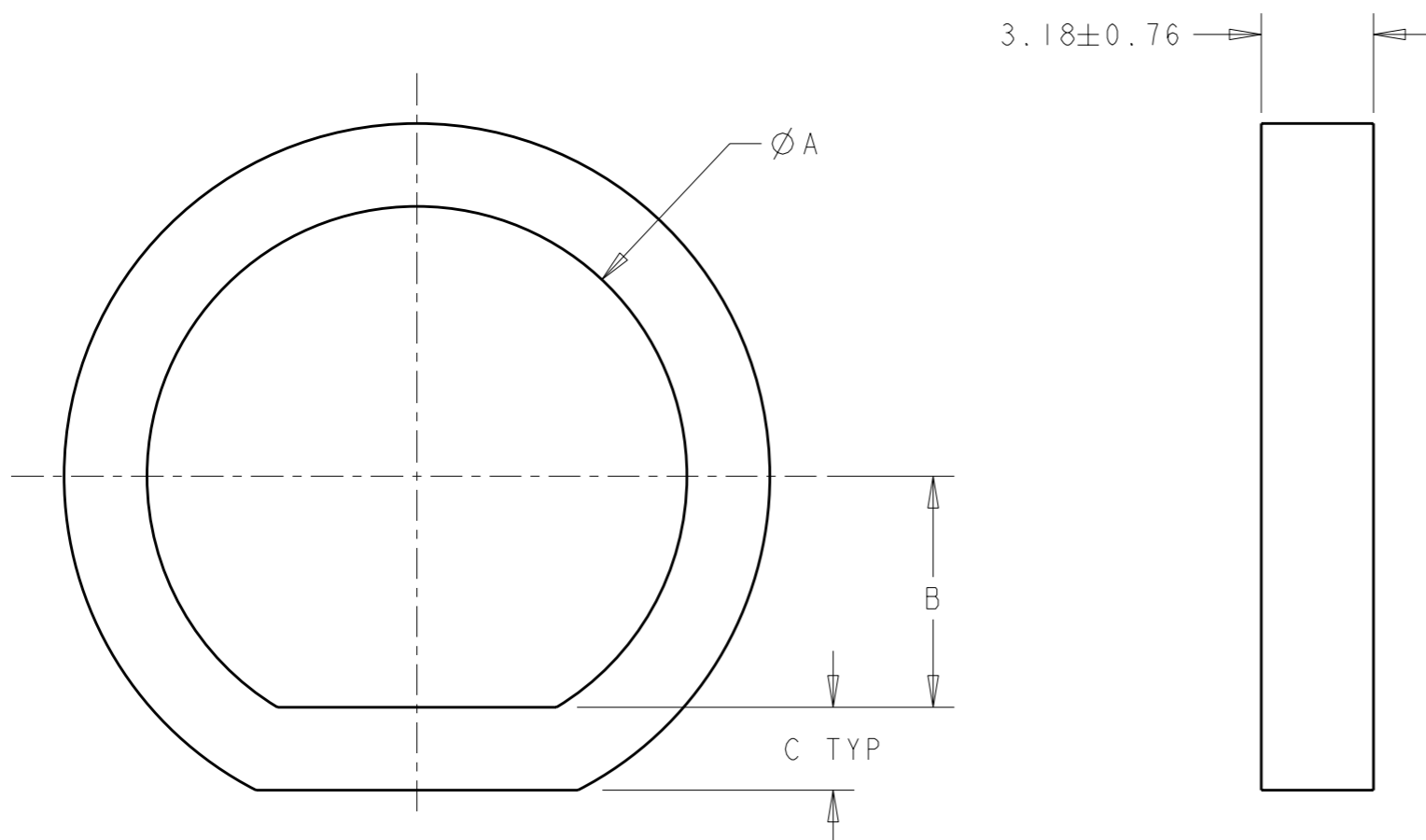

MATERIAL: NEOPRENE CLOSED CELL SPONGE, COLOR-BLACK.

PRELIMINARY	1.50	6.55	15.3	1445420-8
	2.35	10.5	23.1	1445420-7
	2.35	5.25	12.5	1445420-6
	2.35	6.0	14.0	1445420-5
	2.35	4.2	9.25	1445420-4
	2.35	4.5	10.9	1445420-3
	2.35	8.5	18.5	1445420-2
	2.35	6.55	15.3	1445420-1
	C	B	A	PART NUMBER

<small>THIS DRAWING IS A CONTROLLED DOCUMENT FOR TYCO ELECTRONICS CORPORATION IT IS SUBJECT TO CHANGE AND THE CONTROLLING ENGINEERING ORGANIZATION SHOULD BE CONTACTED FOR THE LATEST REVISION.</small>		DWN G DOUTY 04JUN2003 CHK H. WALEEM 18JUL2003 APVD H. WAKFFM 18JUL2003		Tyco Electronics Harrisburg, PA 17105-3608	
DIMENSIONS: mm		TOLERANCES UNLESS OTHERWISE SPECIFIED: 0 PLC ±0 1 PLC ±0.51 2 PLC ±0.51 3 PLC ±- 4 PLC ±- ANGLES ±-		NAME SEAL, PANEL PRODUCT SPEC - APPLICATION SPEC - WEIGHT -	
MATERIAL		FINISH -		SIZE A3 CAGE CODE 00779 DRAWING NO C-1445420 RESTRICTED TO -	
CUSTOMER DRAWING				SCALE 5:1 SHEET 1 OF 1 REV C	