

1-480288-0 Product Details

[Share](#) [Print](#) [Email](#)

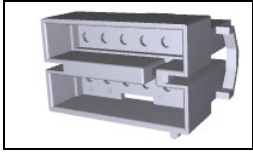

1-480288-0

TE Internal Number: 1-480288-0

Active

[View 3D PDF](#)

.200" Centerline, 250 V, 13 A max.

Always EU RoHS/ELV Compliant (Statement of Compliance)

Product Highlights:

- Commercial MATE-N-LOK Product Line
- Wire-to-Panel / Wire-to-Wire
- Applies To Panel, Applies To Wire/Cable
- Connector
- Housing

[View all Features](#)

Quick Links

- ▶ [Pricing & Availability](#)
- ▶ [Search for Tooling](#)
- ▶ [View Mating Products \(1\)](#)
- ▶ [View Contacts \(139\)](#)
- ▶ [Product Feature Selector](#)
- ▶ [Contact Us About This Product](#)

[Add to My Part List](#) [Request Sample](#) [Find Similar Products](#) [Buy Product](#)

Documentation & Additional Information

Product Drawings:

- [CAP, 12 CIRCUIT, MOTOR MOUNT, COMMERCIAL MATE-N-LOK\(TM\)](#) (PDF, English)

Catalog Pages/Data Sheets:

- [SOFT_SHELL_PIN_SOCKET_CONNECTORS_STANDARD_DENSITY](#) (PDF, English)

Product Specifications:

- None Available

Application Specifications:

- [Commercial MATE-N-LOK Pin And Socket Contacts](#) (PDF, English)
- [MATE-N-LOK Commercial Pin and Socket Contacts](#) (PDF, Japanese)

Instruction Sheets:

- [MATE-N-LOK Motor Mount Connectors](#) (PDF, English)
- [Commoning Tabs 60843-1, 60842-1, 350444-1, and 35044...](#) (PDF, English)
- [Universal, Commercial, and .140 MATE-N-LOK Contact ...](#) (PDF, English)

CAD Files: (CAD Format & Compression Information)

- [2D Drawing \(DXF, Version F\)](#)
- [3D Model \(IGES, Version F\)](#)
- [3D Model \(STEP, Version F\)](#)

[List all Documents](#)

Additional Information:

- [Product Line Information](#)

Related Products:

- [Tooling](#)
- [Mating Products \(1\)](#)
- [Contacts \(139\)](#)

Product Features (Please use the Product Drawing for all design activity)

Product Type Features:

- Product Line = Commercial MATE-N-LOK
- Product Type = Connector
- Connector Type = Housing
- Sealed = No
- UL File Number = E28476
- CSA File Number = LR 16455

Mechanical Attachment:

- Mating Retention Type = Positive Lock
- Panel Mount Retention = With
- Panel Mount Retention Type = Locking Ear

Electrical Characteristics:

- Operating Voltage Reference = AC
- Operating Voltage (VAC) = 250

Dimensions:

- Panel Thickness (mm [in]) = 1.02 - 2.54 [0.040 - 0.100]

Body Features:

- Row-to-Row Spacing (mm [in]) = 9.14 [0.360]
- Mating Retention = With

Contact Features:

- Contact Type = Pin
- Contact Layout = Dual Row

Housing Features:

- Connector Style = Pin (Cap)
- Housing Color = Natural
- Centerline (mm [in]) = 4.95 [0.195]
- Mating Alignment = With
- Mating Alignment Type = Polarization
- Housing Material = Nylon
- UL Flammability Rating = UL 94V-2

Configuration Features:

- Number of Positions = 12
- Number of Rows = 2

Industry Standards:

- [RoHS/ELV Compliance](#) = RoHS compliant, ELV compliant
- [Lead Free Solder Processes](#) = Not relevant for lead free process
- [RoHS/ELV Compliance History](#) = Always was RoHS compliant
- VDE Tested = No
- Agency/Standard = CSA, UL
- UL Rating = Certified, Recognized

Identification Marking:

- Circuit Identification Feature = With

Environmental:

- Operating Temperature (°C [°F]) = -55 - +105 [-67 - +221]

Conditions for Usage:

- Applies To = Panel, Wire/Cable
- For Use With = Socket (Plug) Housing

Operation/Application:

- Application Use = Wire-to-Panel / Wire-to-Wire

Packaging Features:

- Packaging Method = Package
- Packaging Quantity = 1

Other:

- Brand = AMP

LOC	DIST	REV	DATE	DWN	APVD
CM	00	F	ECO-07-030154	20DEC2007	KW CC

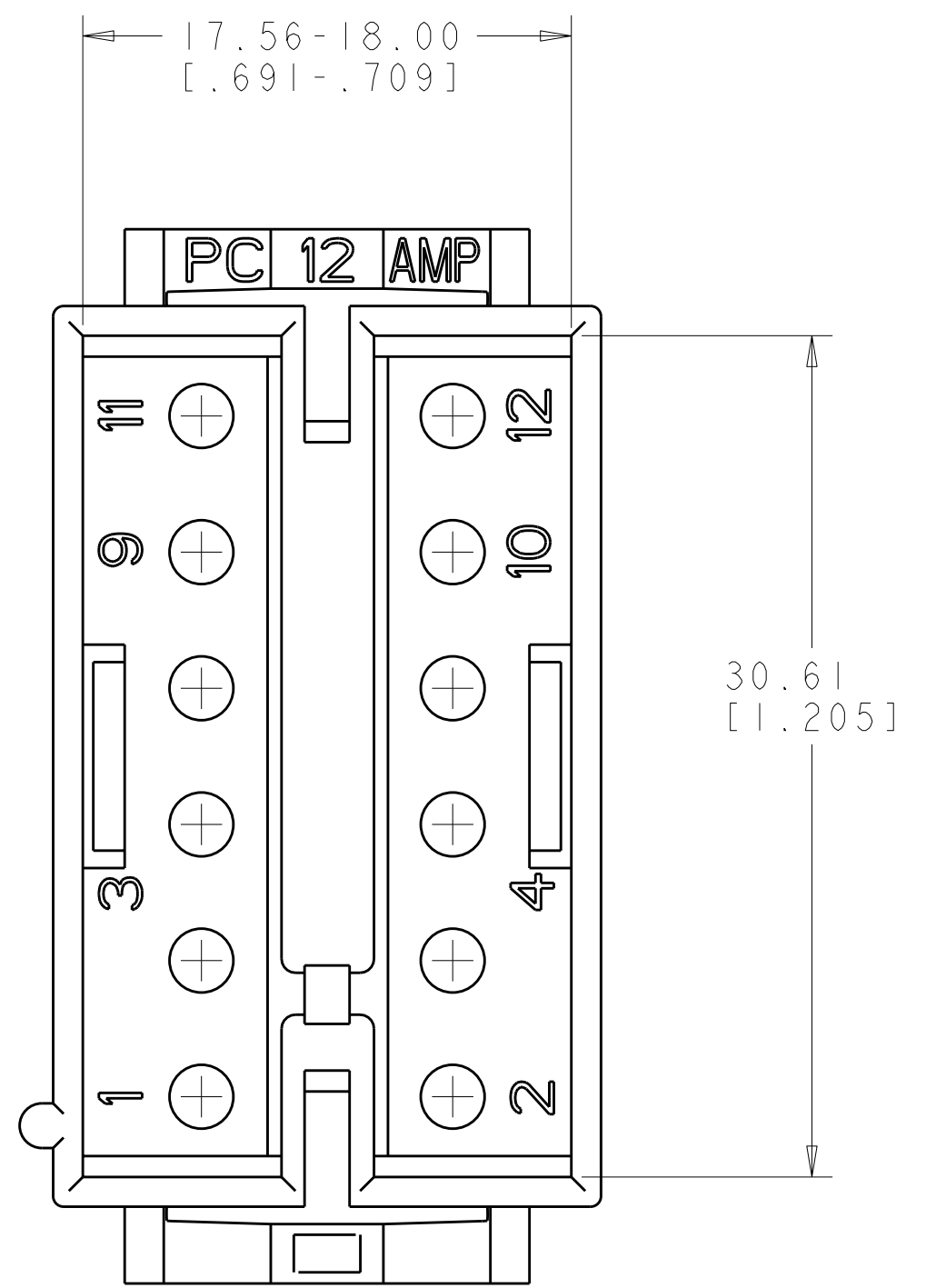
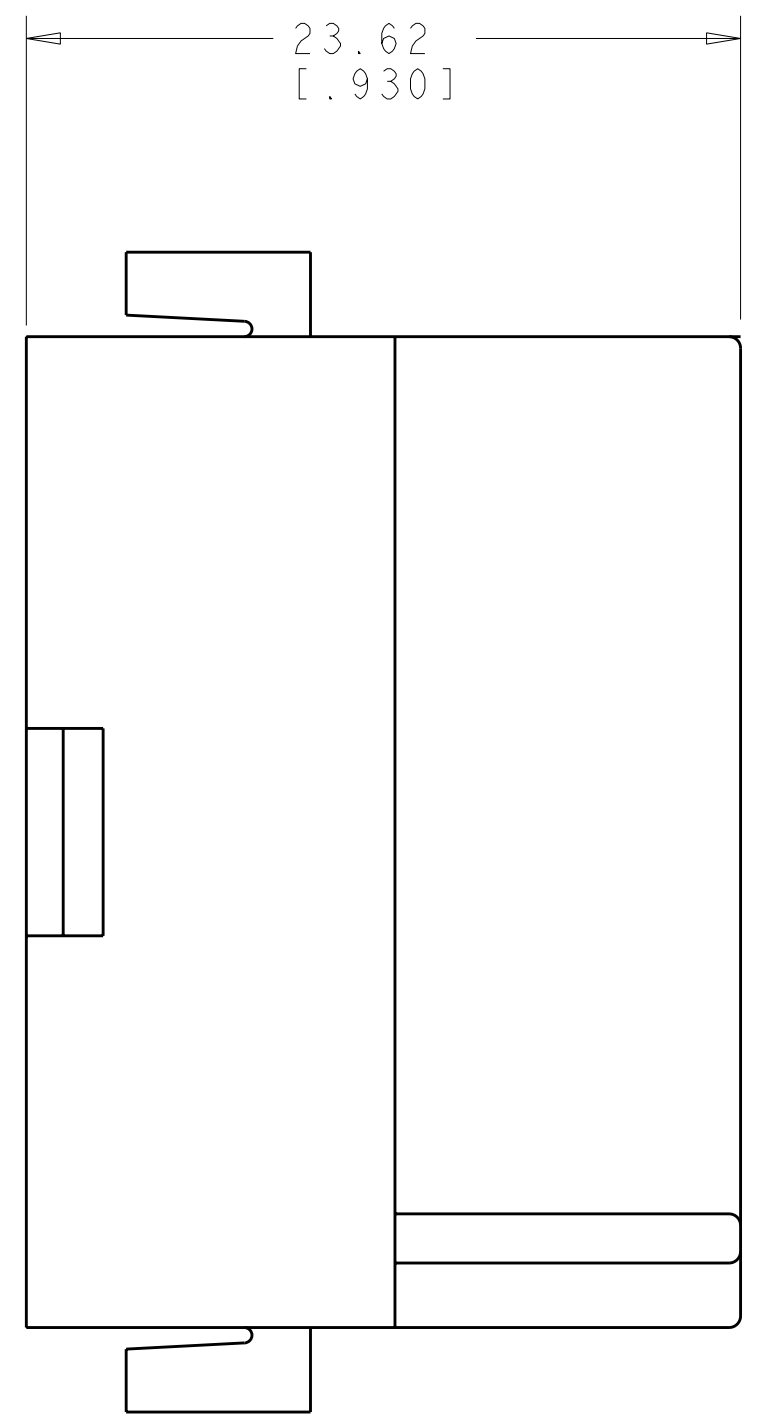
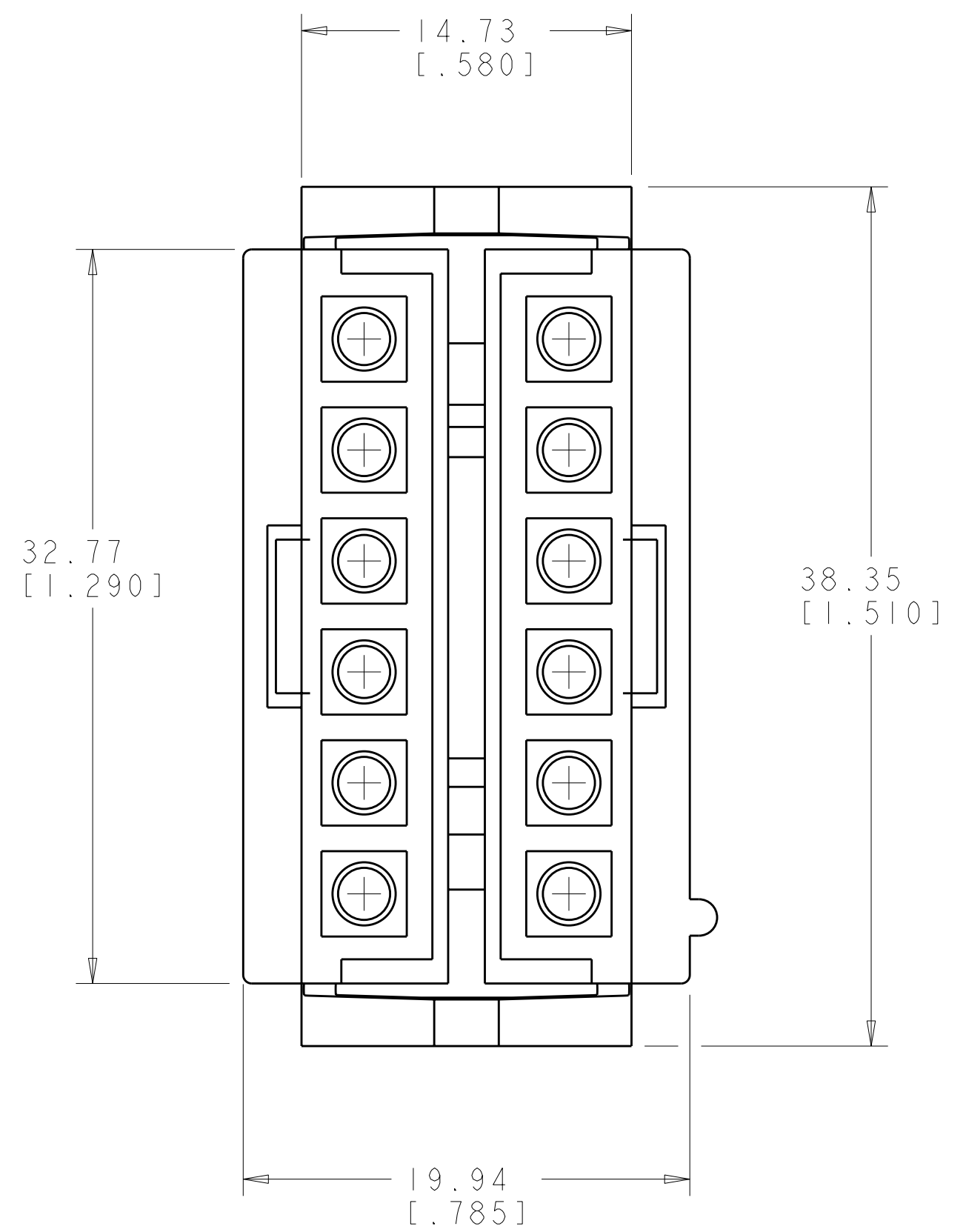

1. TO BE USED WITH COMMERCIAL MATE-N-LOK™ PINS.
2. TO BE USED WITH PLUG 480287.
3. RECOMMENDED PANEL THICKNESS "E" IS 1.02-2.54 [1.040-.100] AND IS DEPENDENT ON "T" AND "R".
4. HOUSING MUST BE INSERTED IN A ROCKING MANNER.
5. THE PANEL MUST BE PUNCHED SO THAT THE HOUSING ENTERS THE PANEL IN THE SAME DIRECTION AS THE PUNCH.
6. PANEL MUST NOT HAVE ANY MATERIAL (PAINT, PORCELAIN, ETC.) APPLIED IN THE MOUNTING HOLE AREA THAT WOULD DECREASE RETENTION OF THE HOUSING IN THE PANEL.

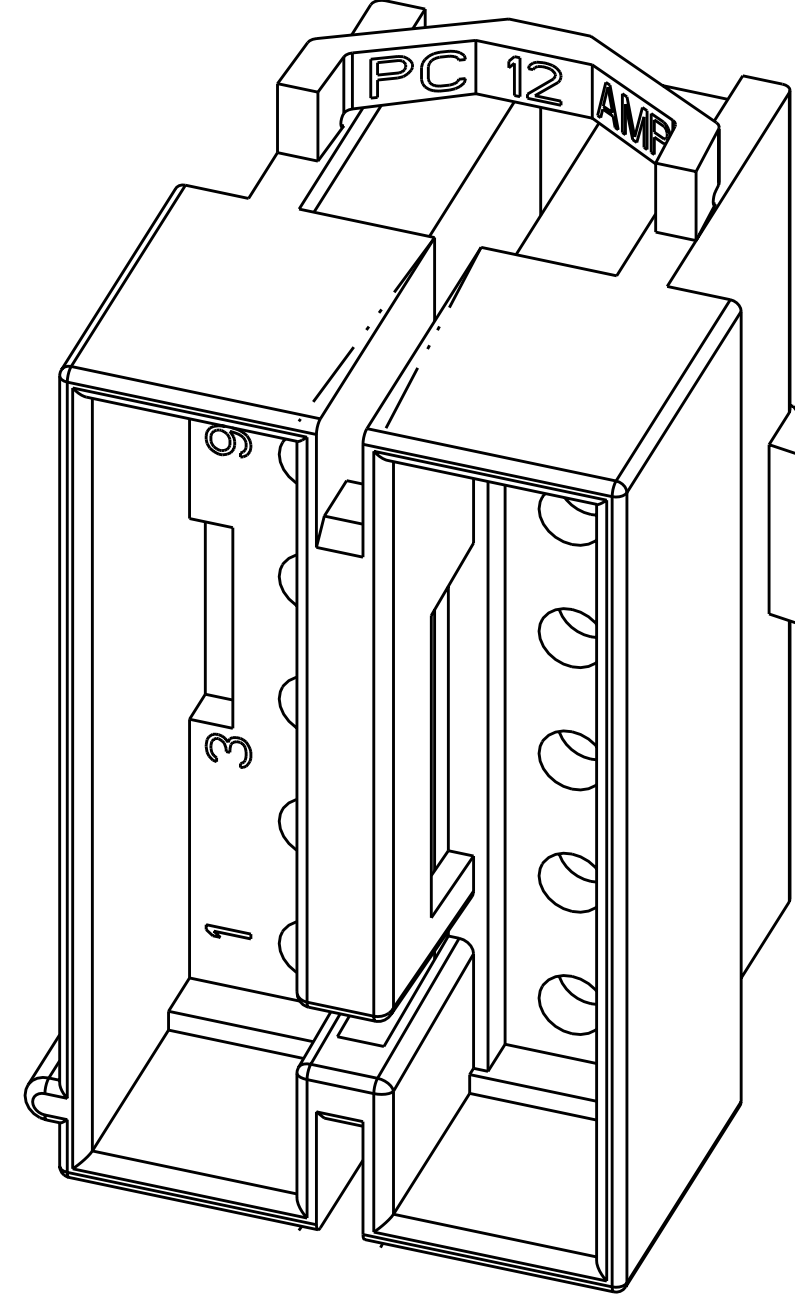
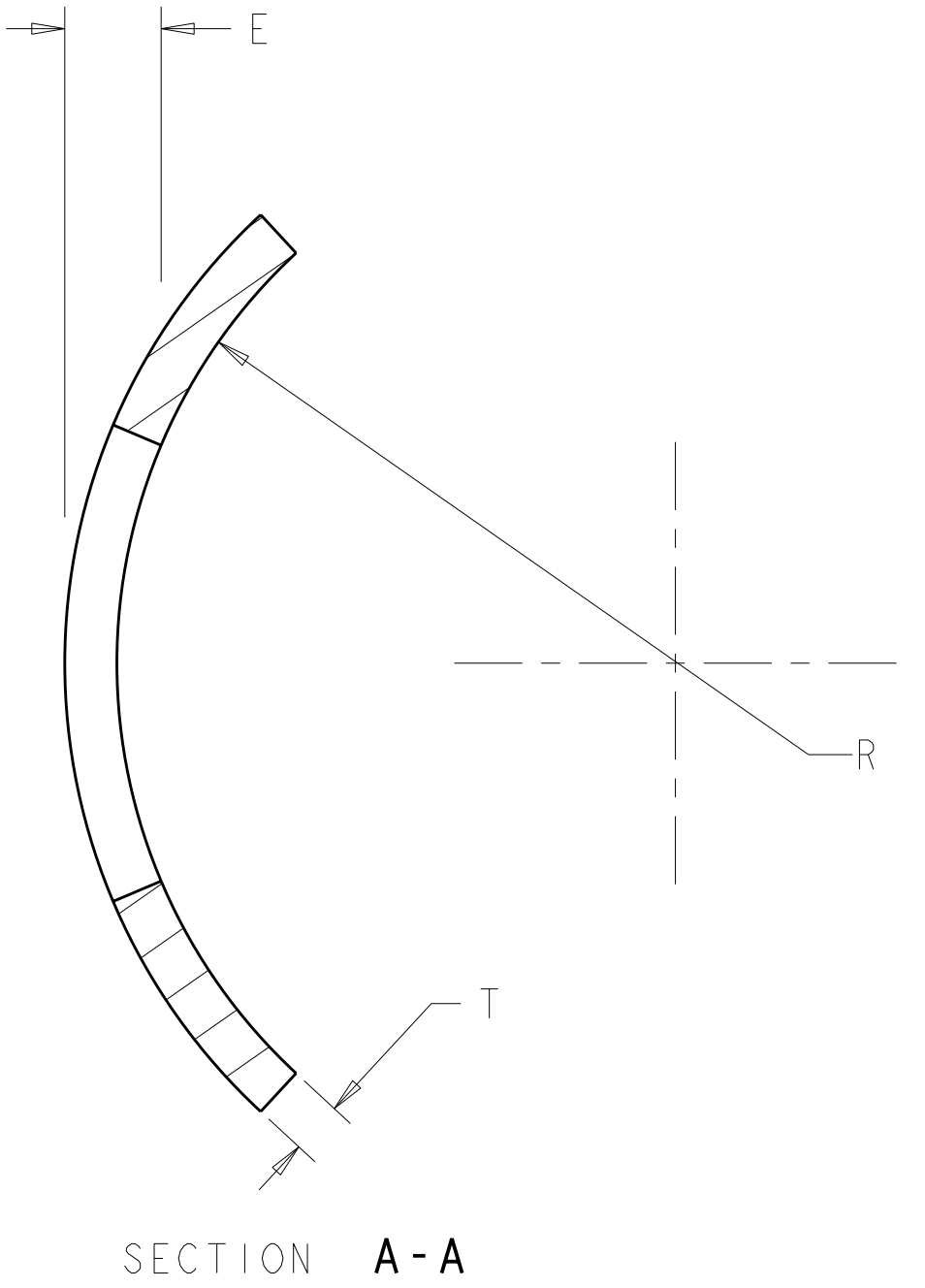
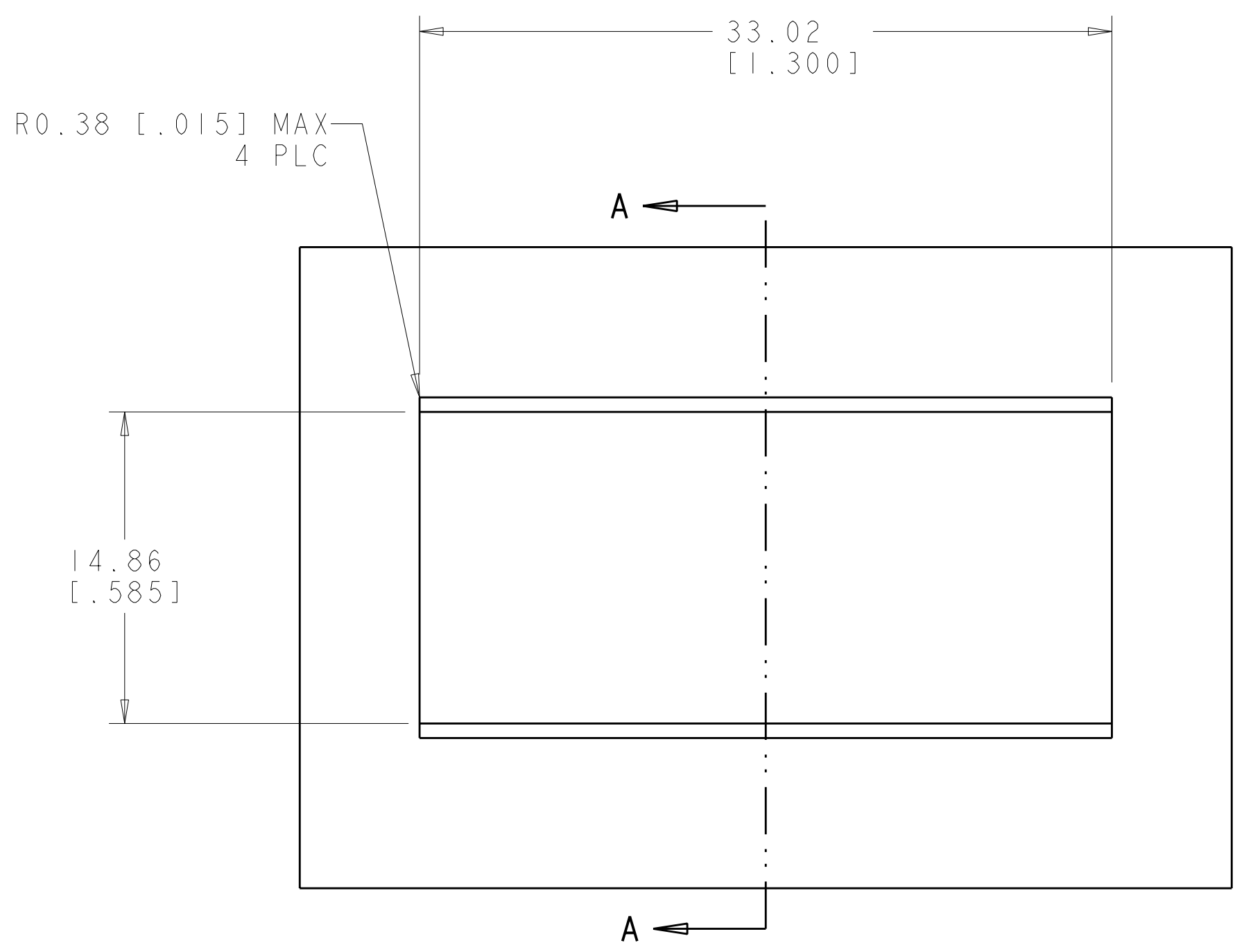
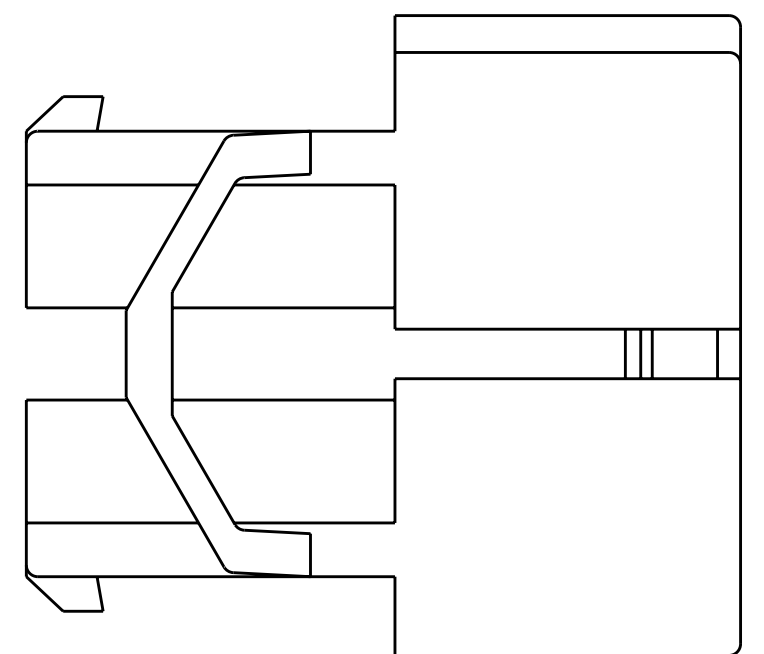

RECOMMENDED CUT OUT

0.329 IN ³	1-480288-0
VOLUME	PART NUMBER

DIMENSIONS: mm [INCHES] TOLERANCES UNLESS OTHERWISE SPECIFIED: 9 PLC ± 1 PLC ±0.13 [1.005] 5 PLC ± 4 PLC ± ANGLES ±40° 30' FINISH -		DWN R. WHITAKER 20DEC2007 CHK C. CASH 20DEC2007 APVD C. CASH 20DEC2007 PRODUCT SPEC APPLICATION SPEC WEIGHT CUSTOMER DRAWING	Tyco Electronics Harrisburg, PA 17105-3608 NAME CAP, 12 CIRCUIT, MOTOR MOUNT, COMMERCIAL MATE-N-LOK(TM) SIZE CAGE CODE DRAWING NO RESTRICTED TO A1100779C=480288 SCALE 4:1 SHEET 1 OF 1 REV F
--	--	--	---

METRIC