

1586055-4 Product Details

[+ Share](#) [Print](#) [Email](#)

Detailed product features are not currently available online.

Product features can often be found by referring to the available documents. [Contact us](#) for information about this product.

No Image Available

VAL-U-LOK SKT PHBZ AU 16AWG

 Always EU RoHS/ELV Compliant (Statement of Compliance)

Quick Links

- [▶ Pricing & Availability](#)
- [▶ Search for Tooling](#)
- [▶ Contact Us About This Product](#)

1586055-4

TE Internal Number: 1586055-4

 **Active**

[Add to My Part List](#)

[Buy Product](#)

Documentation & Additional Information

Product Drawings:

- [TERMINAL, SOCKET VAL-U-LOK\(TM\)](#) (PDF, English)

Catalog Pages/Data Sheets:

- [SOFT_SHELL_PIN_AND_SOCKET_CONNECTORS_CATALOG](#) (PDF, English)

Product Specifications:

- [VAL-U-LOK Connectors](#) (PDF, English)

Application Specifications:

- [VAL-U-LOK Series Headers and Connectors](#) (PDF, English)

Instruction Sheets:

- None Available

CAD Files:

- None Available

Related Products:

- [Tooling](#)

[List all Documents](#)

THIS DRAWING IS UNPUBLISHED. RELEASED FOR PUBLICATION
 © COPYRIGHT BY TYCO ELECTRONICS CORPORATION. ALL RIGHTS RESERVED.

LOC		DIST		REVISIONS			
P	LTR	DESCRIPTION		DATE	DWN	APVD	
	C2	REVISED PER ECR-10-013247		25JUN10	HMR	KR	

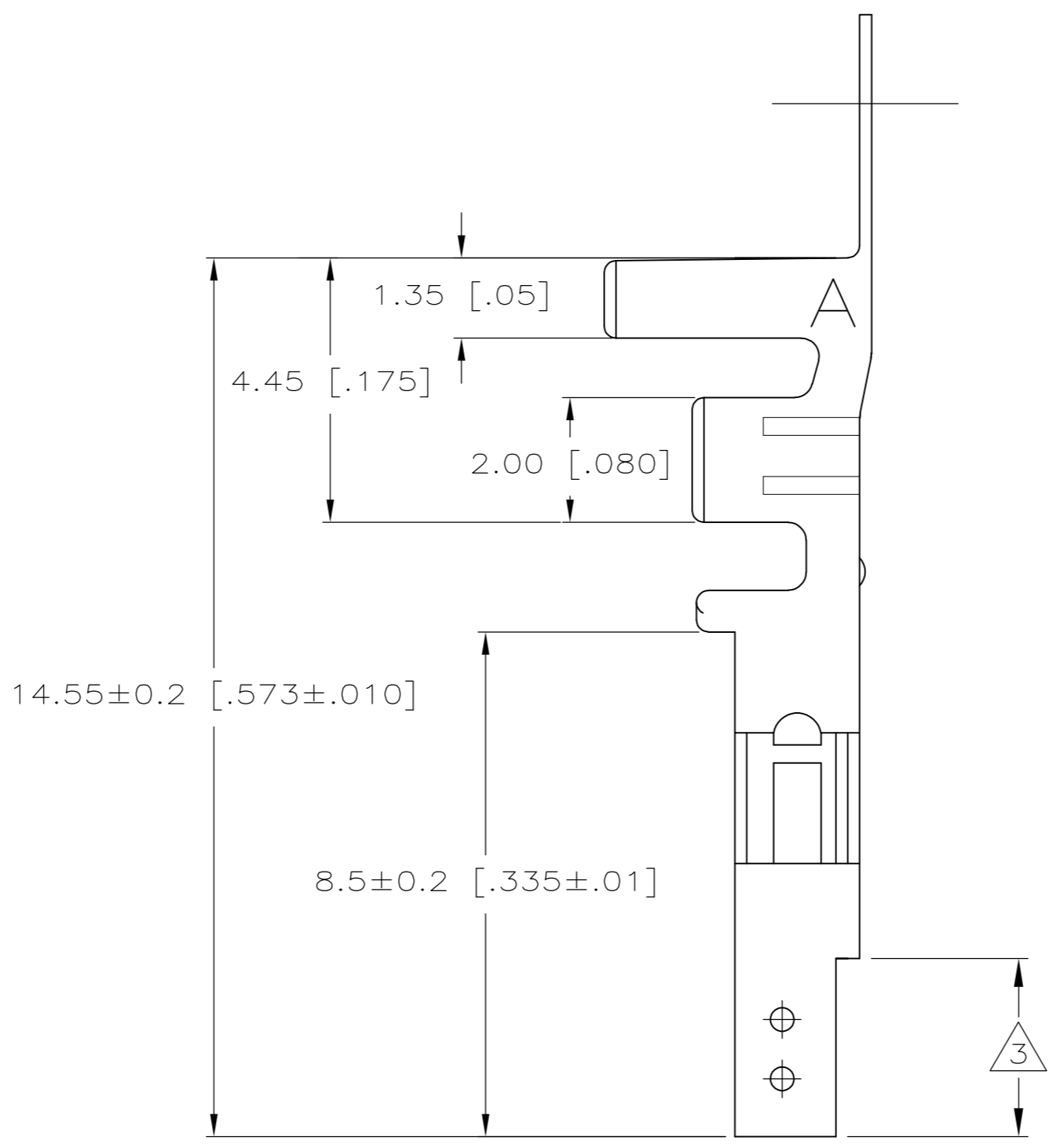
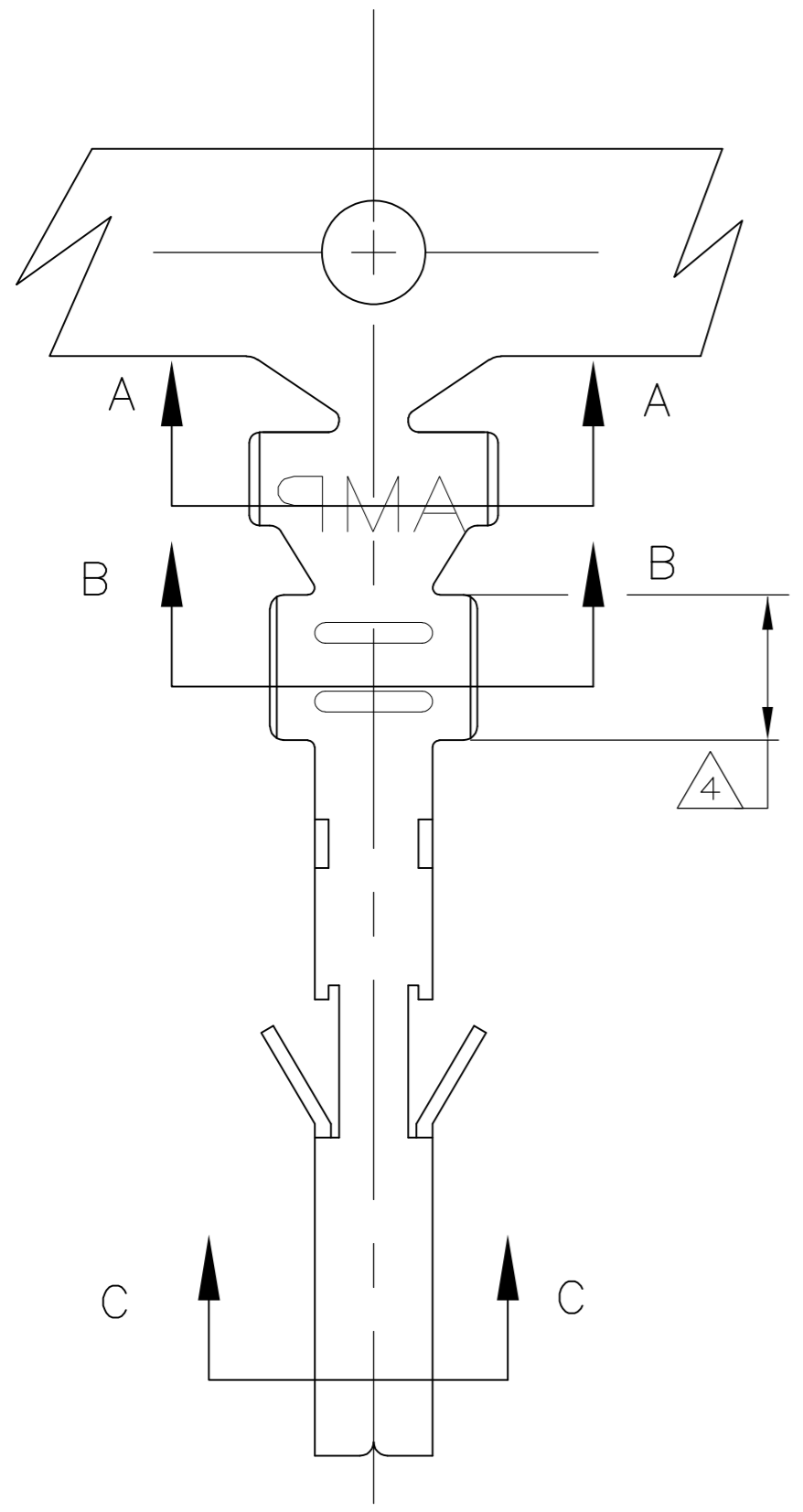

- 1 WIRE RANGE: 1.31mm² (16 AWG).
- 2 INSULATION RANGE 3.10 [.122] MAXIMUM DIAMETER
- 3 FINISH: 0.76μm MINIMUM GOLD OVER 1.27μm MINIMUM NICKEL REQUIRED ON INNER SURFACE, PERMITTED ON OUTER SURFACE.
- 4 FINISH: 2.54μm MINIMUM TIN ON ALL SURFACES IN THIS AREA.
- 5 FINISH: 2.54μm MINIMUM PRE-TIN ALL OVER.

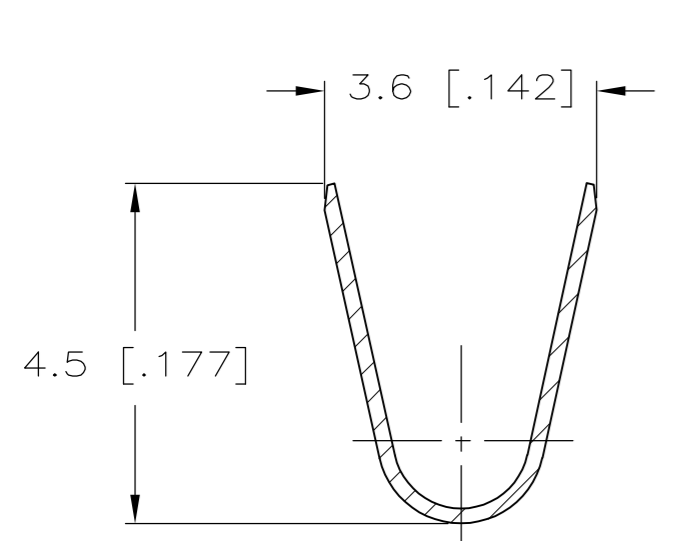

SECTION A-A

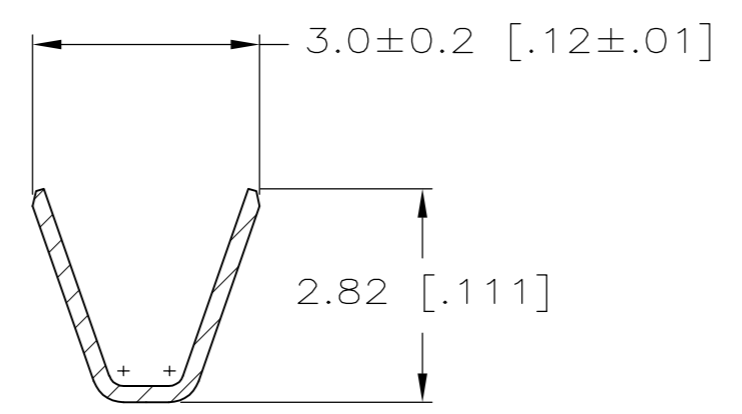

SECTION B-B

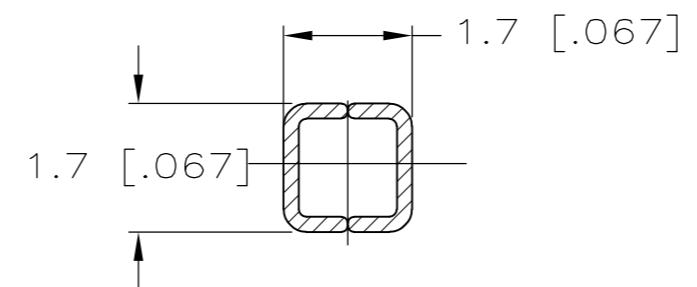

SECTION C-C

GOLD 3 4	PHOS. BRZ.	1586055-4
PRE-TIN 5	PHOS. BRZ.	1586055-3
GOLD 3 4	BRASS	1586055-2
PRE-TIN 5	BRASS	1586055-1
FINISH:	MATERIAL:	PART NO.

METRIC

THIS DRAWING IS A CONTROLLED DOCUMENT.		DWN S. HOOVER 15-NOV-2004	Tyco Electronics Corporation Harrisburg, PA 17105-3608	
DIMENSIONS: mm [INCHES]		CHK D. COLEY 15-NOV-2004	NAME	
TOLERANCES UNLESS OTHERWISE SPECIFIED:		APVD D. COLEY 15-NOV-2004	TERMINAL, SOCKET VAL-U-LOK(TM)	
0 PLC ±		PRODUCT SPEC	SIZE A2	CAGE CODE 00779
1 PLC ± 0.15 [.006]		APPLICATION SPEC	DRAWING NO C=1586055	RESTRICTED TO
2 PLC ± 0.10 [.004]		WEIGHT	SCALE 10:1	SHEET 1 of 1
3 PLC ± 0.05 [.002]		CUSTOMER DRAWING	REV C2	
4 PLC ±				
ANGLES ±				
FINISH				