

© COPYRIGHT 1978 BY AMP INCORPORATED, HARRISBURG, PA. ALL INTERNATIONAL RIGHTS RESERVED. AMP INCORPORATED PRODUCTS COVERED BY U. S. AND FOREIGN PATENTS AND/OR PATENTS PENDING.

3

2

- ▲ SHEET METAL SCREWS NOT SUPPLIED.
- ▲ INSERT IS ATTACHED TO STRAIN RELIEF. AS AN ADDITIONAL ADJUSTMENT FOR SMALL WIRE BUNDLES, IT SHOULD BE CUT OFF AND POSITIONED AS SHOWN BY DOTTED LINES.
- ▲ TWO REQUIRED PER CONNECTOR.
- 4. DETACHABLE INSERT MAY SEPARATE FROM STRAIN RELIEF BODY DURING SHIPPING.

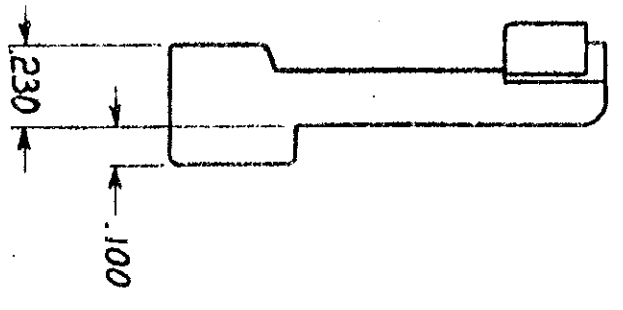
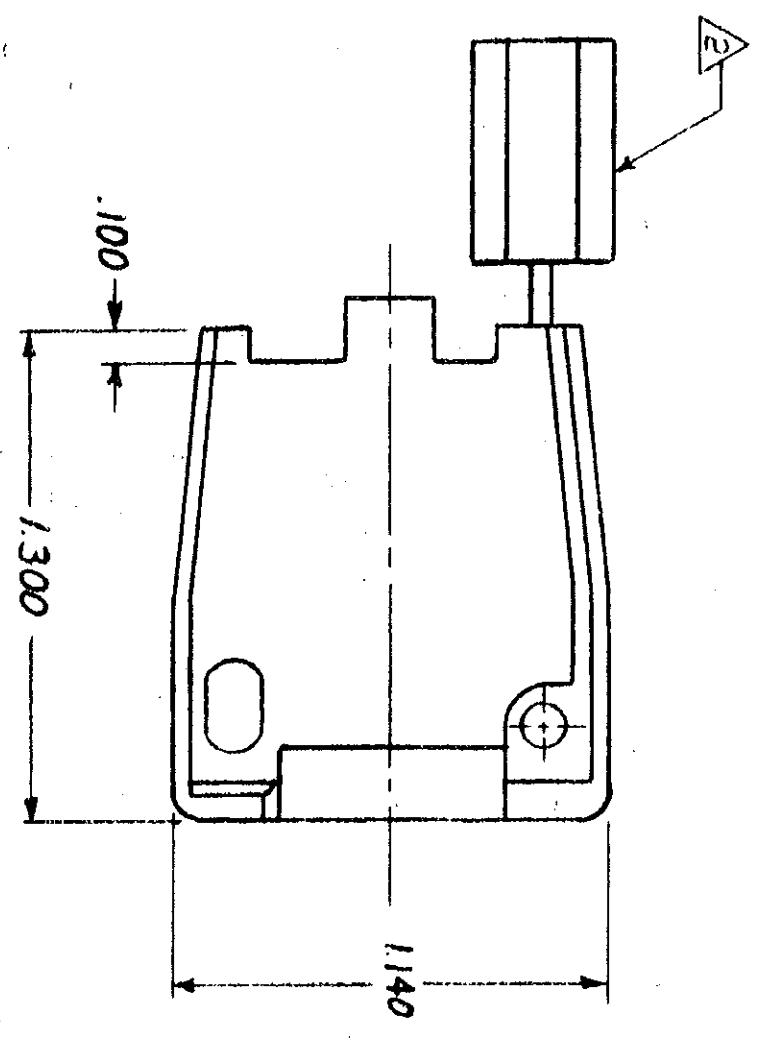
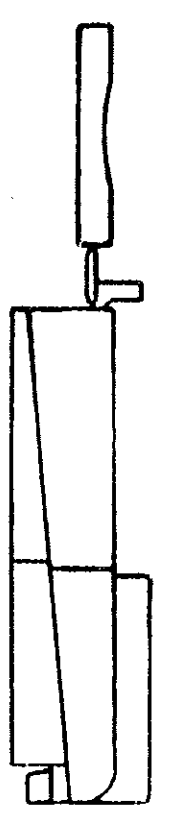

(2 REQ'D) #6 x .375 L.S. TYPE 'B' PAN HEAD SHEET METAL SCREW ▲

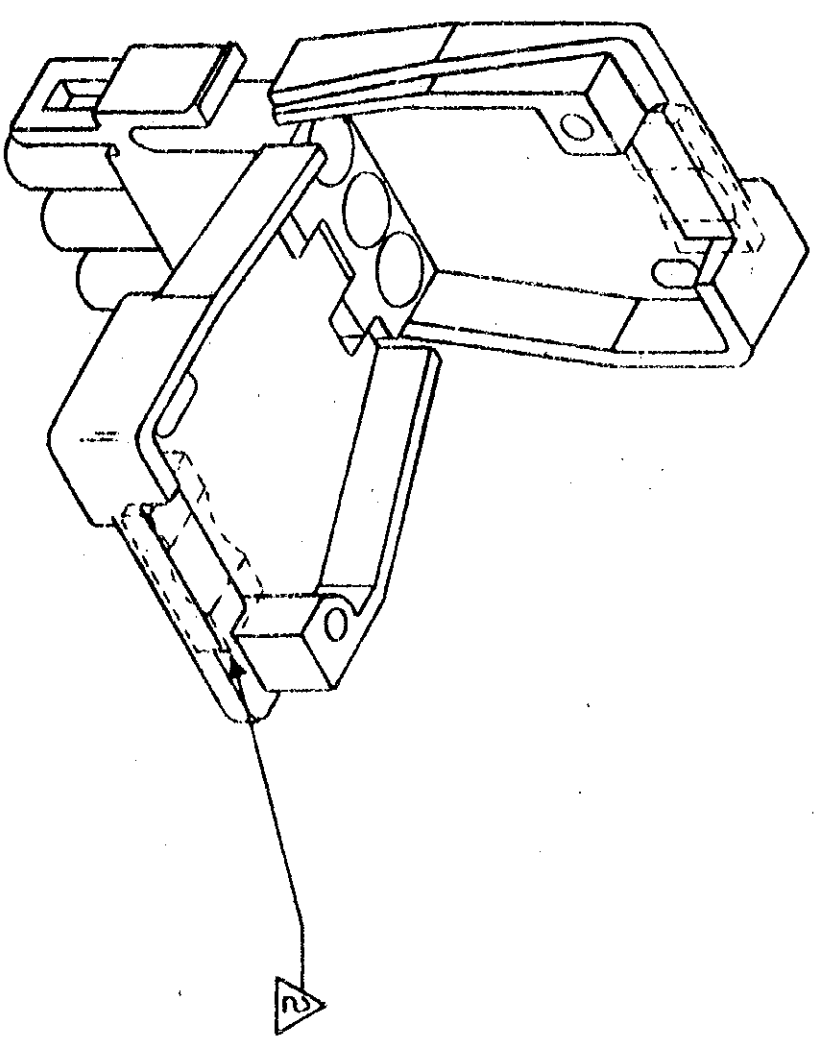

REV	ZONE	TR	DESCRIPTION	DATE	APPROVED
0			DRWG RELEASED PER M-5037	10-23-78	CE/BH
1			CHANGED SCREW LENGTH PER M-5385	6-25-79	MSE/DA
1			AI RESTORATION	6-24-85	ST/AD
2			REV PER ECN CM 705	12/2/86	TS/RS

WIRE BUNDLE	
WITHOUT INSERT	3 @ .190 DIA
WITH INSERT	3 @ .040 DIA

UNLESS OTHERWISE SPECIFIED DIMENSIONS ARE IN INCHES. TOLERANCES ON: DECIMALS ± .015 ANGLES

CONTRACT NO
 DR C. ERSIMAN 10-24-78
 CHK J.S. Steide 11/1/78
 APPO J.C.M. 11-1-78
 APPD J.C.M. 11-1-78

NAME
 STRAIN RELIEF AND INSERT, 3 CIRCUIT, UNIVERSAL MATE-N-LOK™

NATURAL COLOR MATERIAL PART NO
 NYLON 94V-2 A1-640720-0



AMP INCORPORATED Harrisburg, Pa.

FINISH
 SEE TABLE

DSGN APPD
 OTHER APPD

SIZE CODE IDENT NO DRAWING NO
 C 00779 640720

SCALE NTS SHEET 1 OF 1

640720

640720 NOT THE LATEST REVISION