

Distributed by:

JAMECO[®]
ELECTRONICS

www.Jameco.com ♦ 1-800-831-4242

The content and copyrights of the attached
material are the property of its owner.

Jameco Part Number 742119

LOC	DIST	REVISIONS			
F	LYR	DESCRIPTION	DATE	DWN	APVD
C		REVISED PER 0G3B-0913-03	05DEC2003	KW	SR
D		REVISED PER 0G3B-0024-05	10MAR06	KW	SR

- 1 SHEET METAL SCREWS NOT SUPPLIED.
- 2 INSERT IS ATTACHED TO STRIN RELIEF AS AN ADDITIONAL ADJUSTMENT FOR SMALL WIRE BUNDLES. IT SHOULD BE CUT OFF AND POSTIONED AS SHOWN.
- 3 TWO REQUIRED PER CONNECTOR.
- 4. DETACHABLE INSERT MAY SEPARATE FROM STRAIN RELIEF BODY DURING SHIPPING.

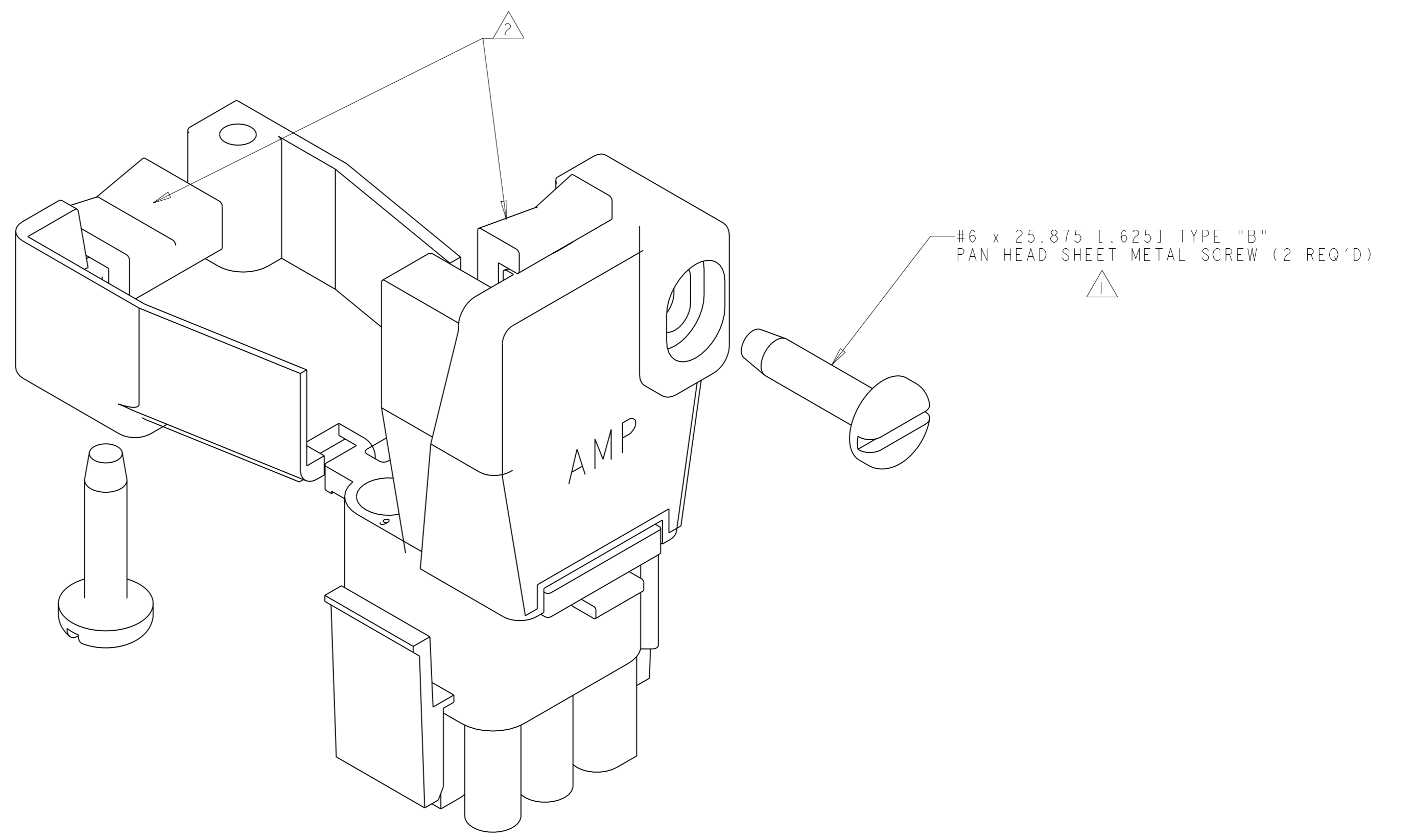
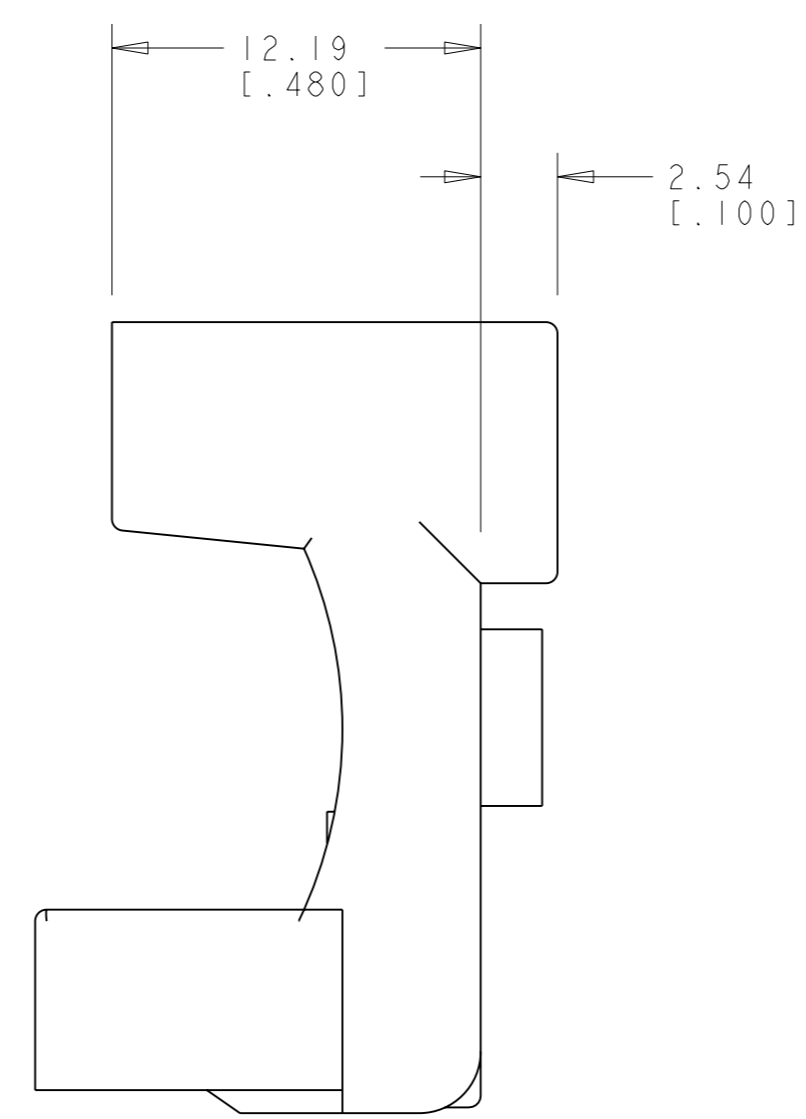
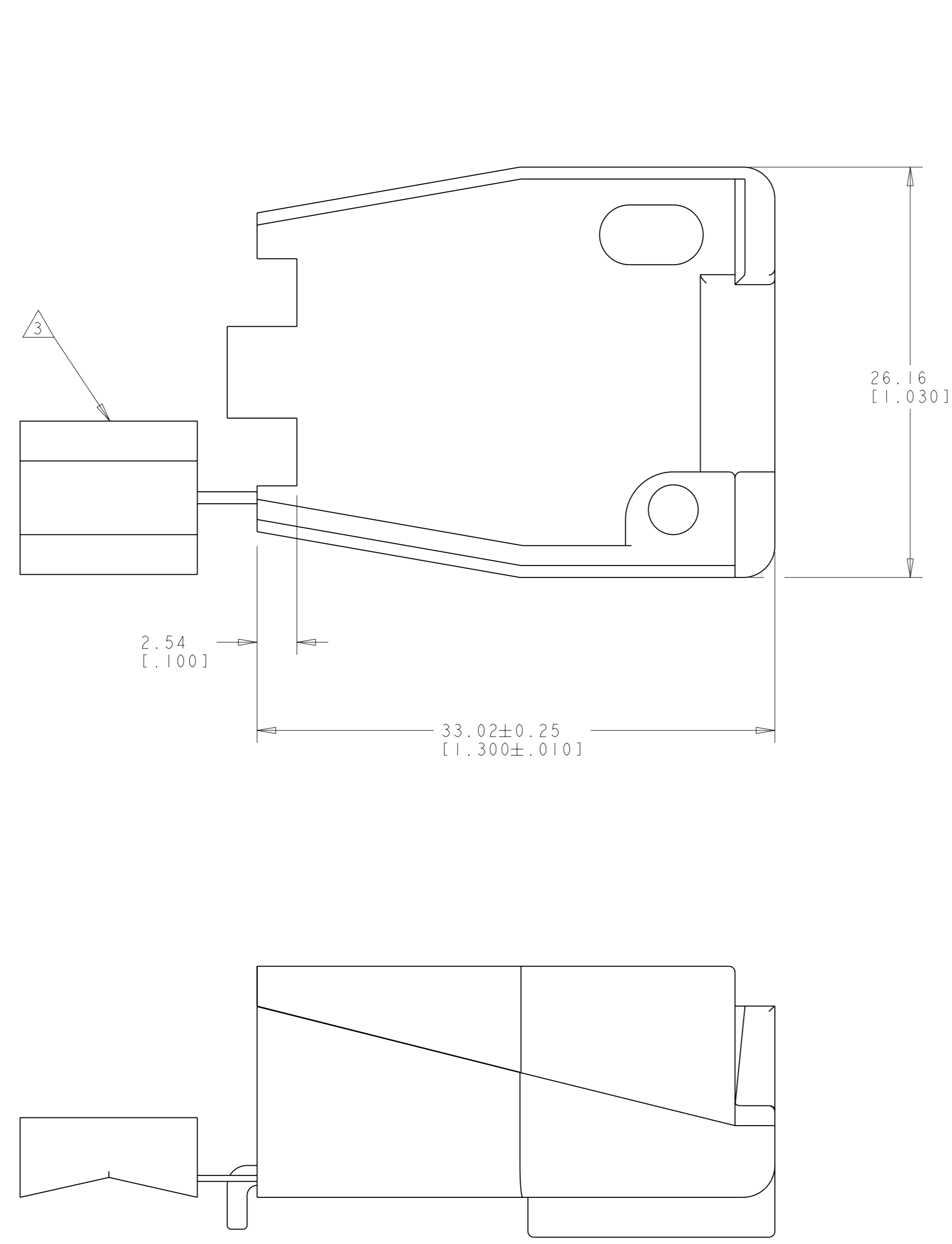

BLACK	NYLON UL94V-2	1-640721-9
NATURAL	NYLON UL94V-2	1-640721-0
COLOR	MATERIAL	PART NUMBER

DIMENSIONS: mm [INCHES]		TOLERANCES UNLESS OTHERWISE SPECIFIED: 0 PLC ± 1 PLC ± 2 PLC ±0.13 [0.005] 3 PLC ± 4 PLC ± ANGLES 40° 30'		DWN: K. WHITAKER 05DEC2003 CHK: S. RIDGILL 05DEC2003 APVD: S. RIDGILL 05DEC2003		Tyco Electronics Harrisburg, PA 17105-3608	
MATERIAL SEE TABLE		FINISH:		NAME: STRAIN-RELIEF AND INSERT, 6 CIRCUIT, UNIVERSAL MATE-N-LOK(TM) APPLICATION SPEC:		SIZE: A CAGE CODE: 00779 DRAWING NO: 640721	
CUSTOMER DRAWING				WEIGHT:		RESTRICTED TO:	

METRIC