



Have a Question?
 Chat with a Product
 Information Specialist

What can we help you find?

[Products](#) |
 [Industries](#) |
 [Resources](#) |
 [About TE](#) |
 [My Account](#) |
 [Innovation](#) |
 [Support Center](#)

1658687-1 Product Details

[Share](#) |
 [Print](#) |
 [Email](#)



1658687-1

TE Internal Number: 1658687-1

Active

[View 3D PDF](#)

Standard Cable Connectors

Always EU RoHS/ELV Compliant (Statement of Compliance)

Product Highlights:

- Connector
- Product Series = HDP-22 (Crimp Snap)
- 26 Positions
- With Enclosure
- Shielded

[View all Features](#)

Quick Links

- ▶ [Pricing & Availability](#)
- ▶ [Search for Tooling](#)
- ▶ [View Mating Products \(4\)](#)
- ▶ [View Receptacle Kits \(4\)](#)
- ▶ [Product Feature Selector](#)
- ▶ [Contact Us About This Product](#)

[Add to My Part List](#) |
 [Request Sample](#) |
 [Find Similar Products](#) |
 [Buy Product](#)

Documentation & Additional Information	
<p>Product Drawings:</p> <ul style="list-style-type: none"> • KIT, RCPT, SHIELDING HARDWARE, SIZE 2, 26 POSN, HDP-... (PDF, English) <p>Catalog Pages/Data Sheets:</p> <ul style="list-style-type: none"> • AMPLIMITE Subminiature D Connectors - Cable Connectors (PDF, English) <p>Product Specifications:</p> <ul style="list-style-type: none"> • AMPLIMITE* HDP-22 Subminiature D Connector with Remo... (PDF, English) <p>Application Specifications:</p> <ul style="list-style-type: none"> • AMPLIMITE HDP-22 Connectors and High-Density 22DF Co... (PDF, English) <p>Instruction Sheets:</p> <ul style="list-style-type: none"> • Shielding Hardware Kits w/AMPLIMITE hde-20 hdp-20 an... (PDF, English) • AMPLIMITE HDP-22 Connectors (Plugs and Receptacles w... (PDF, English) • Insertion/Extraction Tool 91285-1 and Replacement Ti... (PDF, English) <p>CAD Files: (CAD Format & Compression Information)</p> <ul style="list-style-type: none"> • 2D Drawing (DXF, Version 0) • 3D Model (IGES, Version 0) • 3D Model (STEP, Version 0) 	<p>Additional Information:</p> <ul style="list-style-type: none"> • Product Line Information <p>Related Products:</p> <ul style="list-style-type: none"> • Tooling • Mating Products (4) • Receptacle Kits (4)

[List all Documents](#)

Product Features (Please use the Product Drawing for all design activity)	
<p>Product Type Features:</p> <ul style="list-style-type: none"> • Product Type = Connector • Product Series = HDP-22 (Crimp Snap) • Mating Connector Lock = Without • Shell Size = 2 • Shell Type = Full Metal Shell • Grounding Indents = Without • Grade = Standard • Color = Black • Shell Material = Steel • Shield Material = Steel <p>Electrical Characteristics:</p> <ul style="list-style-type: none"> • Shielded = Yes <p>Dimensions:</p> <ul style="list-style-type: none"> • Cable Insulation Diameter (mm [in]) = 4.19 - 11.56 [0.165 - 0.455] • Cable Diameter (Max.) (mm [in]) = 11.68 [0.460] <p>Body Features:</p> <ul style="list-style-type: none"> • Shell Plating = Tin • Shield Plating = Tin • Insert Material = Thermoplastic 	<p>Contact Features:</p> <ul style="list-style-type: none"> • Contact Size = 22 <p>Housing Features:</p> <ul style="list-style-type: none"> • Enclosure = With • Connector Style = Receptacle <p>Configuration Features:</p> <ul style="list-style-type: none"> • Number of Positions = 26 • Preloaded = No • Pre-Assembled = No <p>Industry Standards:</p> <ul style="list-style-type: none"> • RoHS/ELV Compliance = RoHS compliant, ELV compliant • Lead Free Solder Processes = Not relevant for lead free process • RoHS/ELV Compliance History = Always was RoHS compliant • Insert Flammability Rating = UL 94V-0 <p>Packaging Features:</p> <ul style="list-style-type: none"> • Packaging Method = Bulk • Packaging Quantity = 100 <p>Other:</p> <ul style="list-style-type: none"> • Brand = AMP • Comment = Components shipped unassembled, each part bulk-packaged.

THIS DRAWING IS UNPUBLISHED. RELEASED FOR PUBLICATION .19
 (C) COPYRIGHT 19 BY AMP INCORPORATED. ALL RIGHTS RESERVED.

LOC	DIST	REVISIONS					
GP	00	P	LTR	DESCRIPTION	DATE	DWN	APVD
		0		RELEASED PER EC 0513-0209-03	02 JAN 04	LB	5B

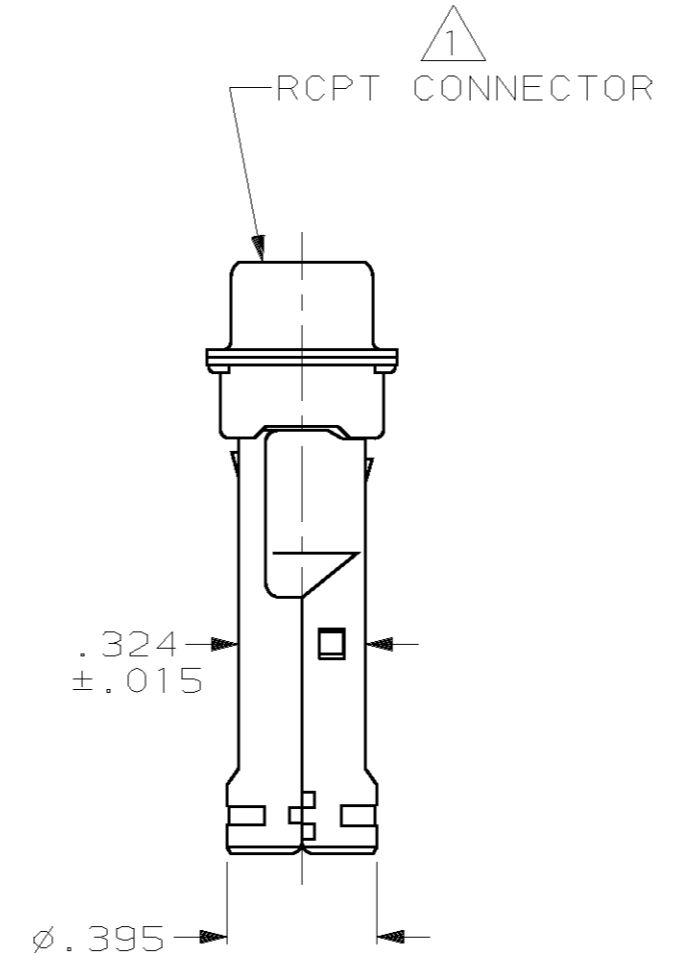
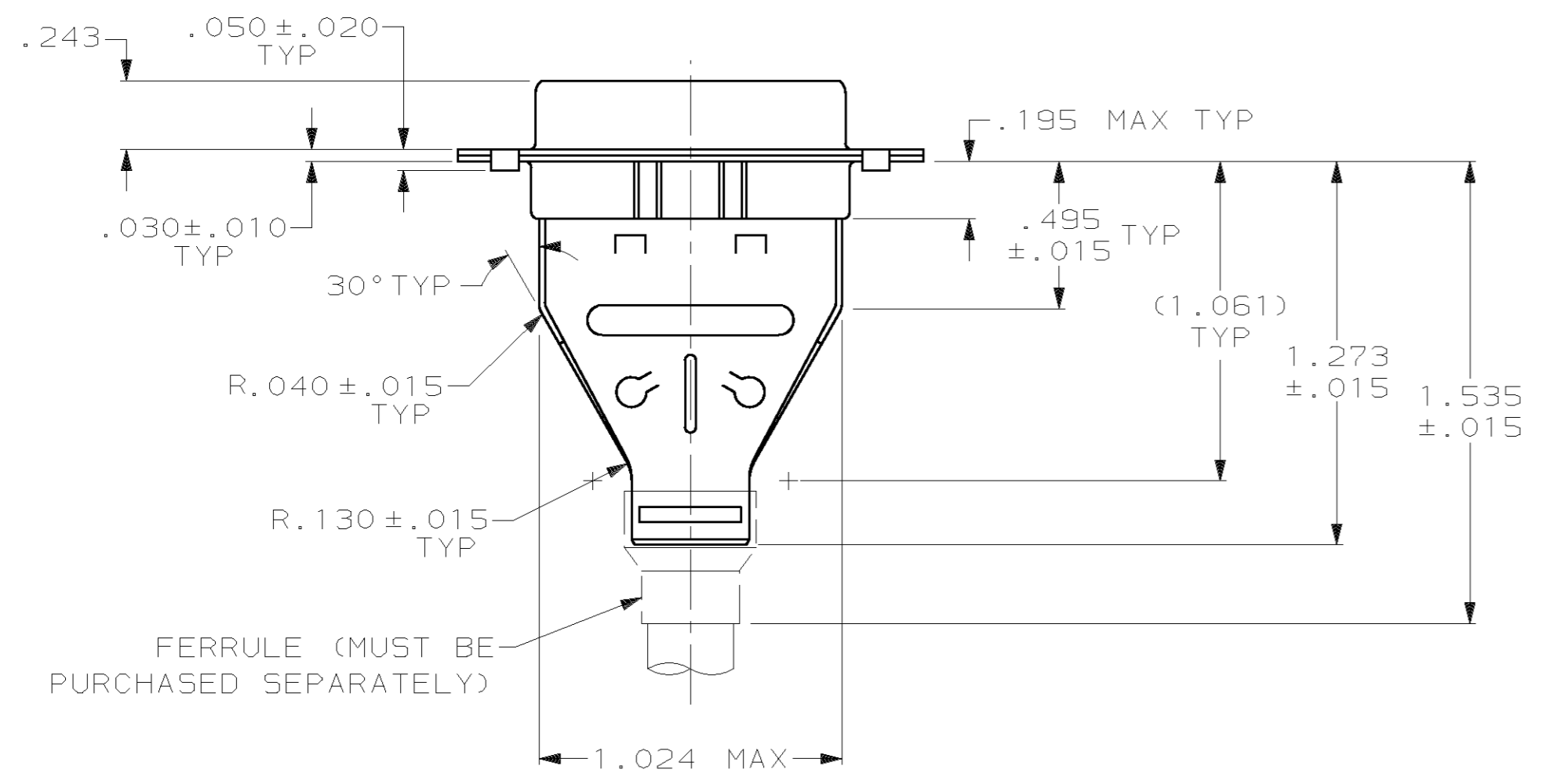
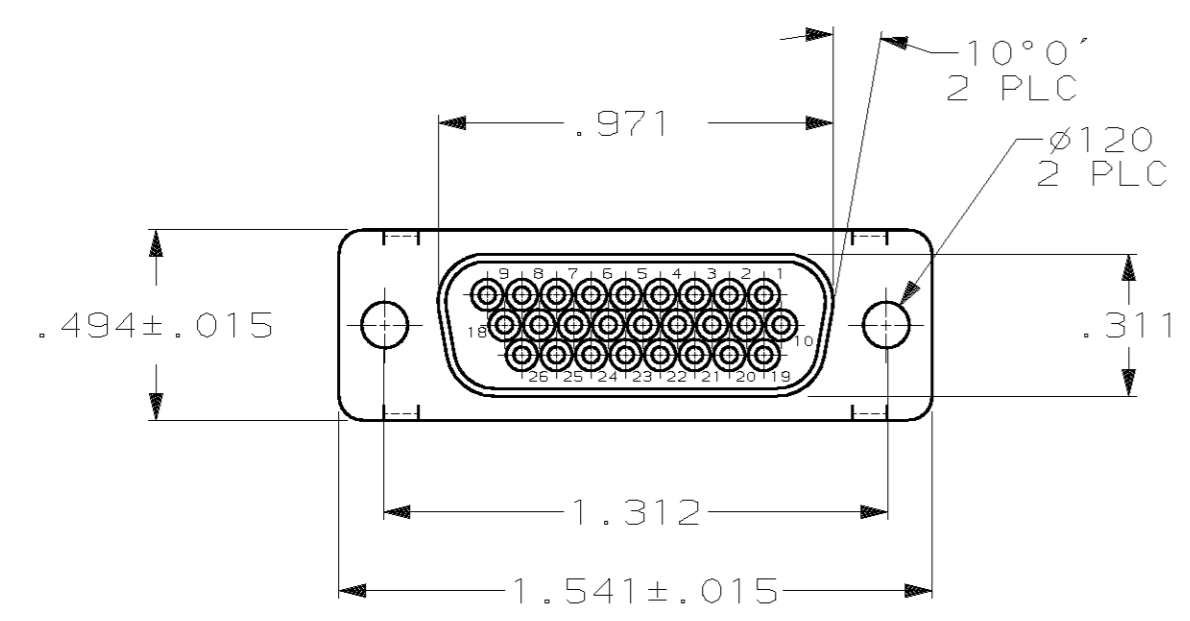

- ① RCPT ACCEPTS 22 DF SOCKET CONTACTS (CONTACTS MUST BE ORDERED SEPARATELY).
- 2. ALL PARTS SHIPPED UNASSEMBLED, EACH PART INDIVIDUALLY BULK PACKED.
- ③ FLAME RETARDANT 94V-0 RATED, GLASS FILLED NYLON, BLACK.
- ④ .000200 MIN. TIN PLATE OVER .000100 MIN. COPPER UNDERPLATE.

1658687-1
 PART NUMBER

THIS DRAWING IS A CONTROLLED DOCUMENT.		DWN L. BAUM 02JAN04	AMP Incorporated Harrisburg, PA 17105-3608
DIMENSIONS: INCH		CHK S. BOLASH 02JAN04	
TOLERANCES UNLESS OTHERWISE SPECIFIED: 0 PLC ±- 1 PLC ±- 2 PLC ±- 3 PLC ±.005 4 PLC ±- ANGLES ±2°		APVD M. WALMSLEY 02JAN04	
MATERIAL HOUSING: ③ SHELLS & SHIELDS: ④ CARBON STEEL		FINISH SHELLS & SHIELDS: ④	
PRODUCT SPEC 108-1268 APPLICATION SPEC 114-10001		NAME KIT, RCPT, SHIELDING HARDWARE, SIZE 2, 26 POSN, HDP-22, AMPLIMIT™	RESTRICTED TO
CUSTOMER DRAWING		SCALE 2:1	SHEET 1 OF 1
		WEIGHT -	REV 0