

Distributed by:

**JAMECO**<sup>®</sup>  
ELECTRONICS

**www.Jameco.com ♦ 1-800-831-4242**

The content and copyrights of the attached  
material are the property of its owner.

Jameco Part Number 1962885

LOC	DIST	REV	DATE	BY	CHK	APPV
GP	00					

REV	DESCRIPTION	DATE	BY	CHK	APPV
C	REVISED PER EC 0S13-0354-04	12OCT04	JG	JK	
D	REVISED PER EC 0S13-0414-04	01APR2005	JAR	JK	
E	REVISED PER ECO-06-006624	26MAR2006	REH	JK	
E1	REVISED PER ECO-07-011809	18/MAY/07	ZMR	JRK	

- 1 MATERIAL: 0.25 THICK COPPER ALLOY.
- 2 FINISH: TIN PLATING PER ASTM B 545, 1.25µm MINIMUM THICKNESS  
ALL OVER NICKEL FLASH PER QQ-N-290. NONPLATED EDGES PERMISSIBLE.
- 3 PADS AND VIAS CHASSIS GROUND.
- 4 DATUM AND BASIC DIMENSION ESTABLISHED BY CUSTOMER.
- 5 REFERENCE APPLICATION SPEC 114-13120, HOLE A, FOR RECOMMENDED  
DRILL HOLE DIAMETER AND PLATING THICKNESSES.

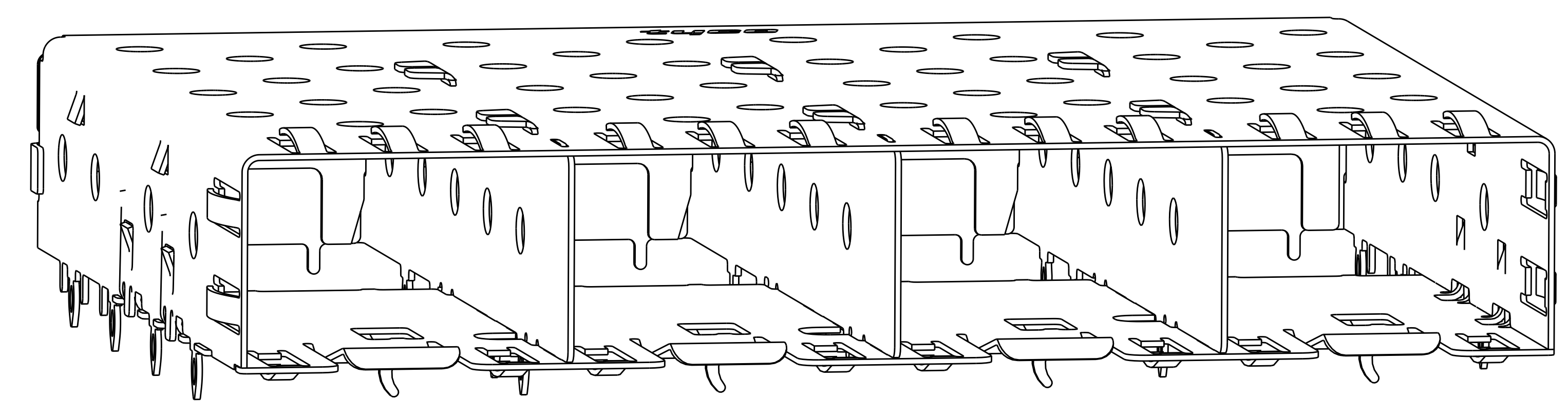
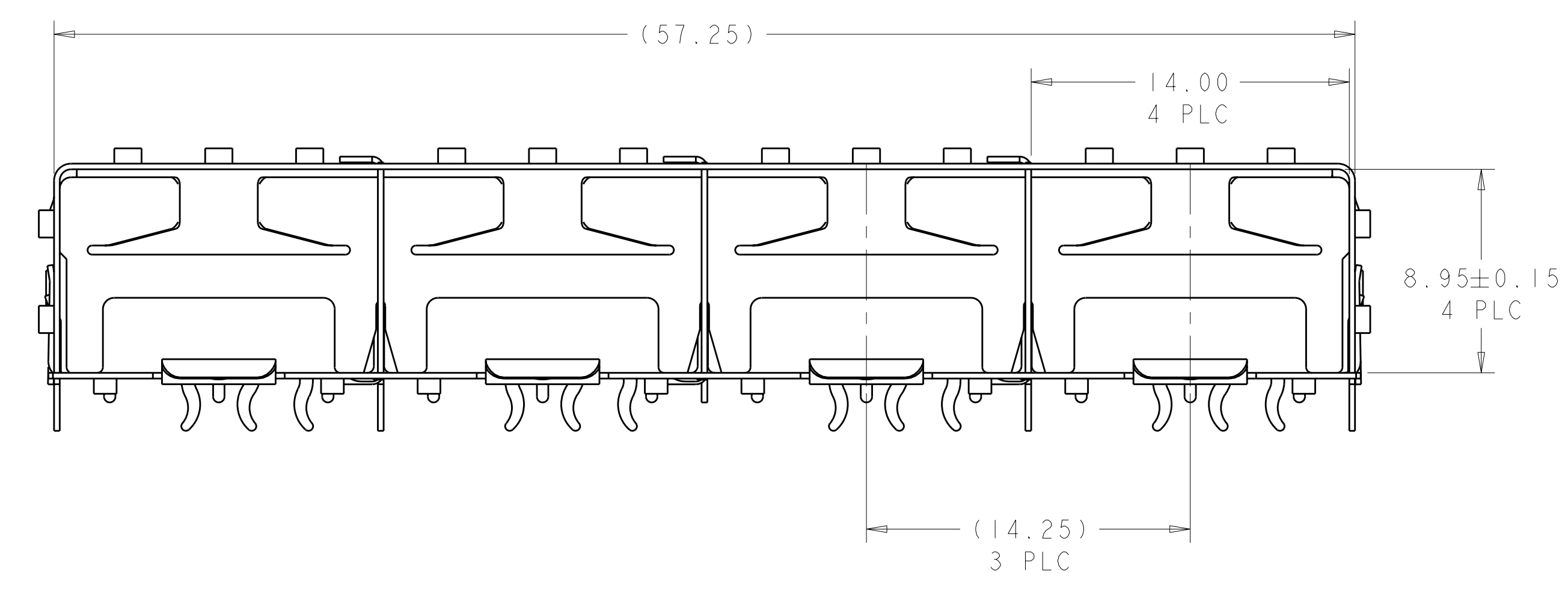
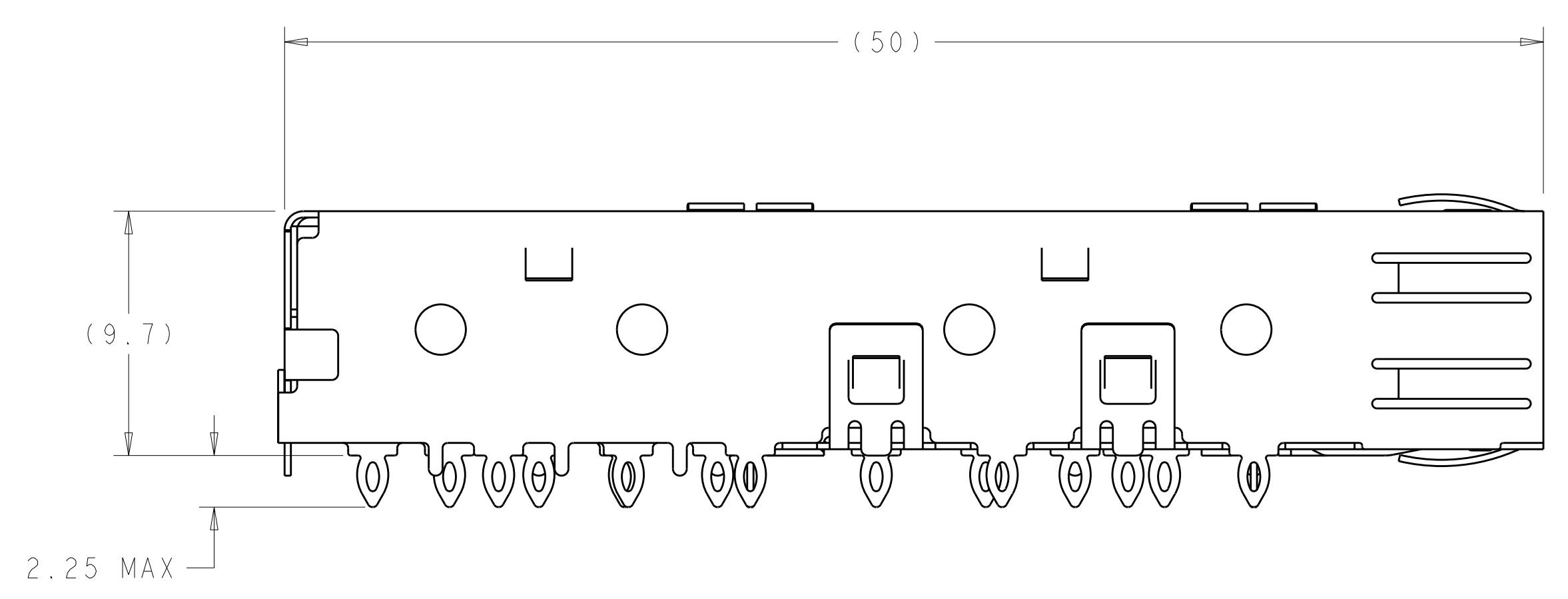

1658744-1  
 1X4 CAGE ASSEMBLY  
 SCALE 6:1

IX4	1658744-1
POSITION	PART NUMBER

<small>THIS DRAWING IS UNPUBLISHED. RELEASED FOR PUBLICATION BY TYCO ELECTRONICS CORPORATION. ALL RIGHTS RESERVED.</small>		DWN M. SHIRK 04JUN03 CHK J. KOPPENHEFFER 06MAY04 APPV M. WALMSLEY 06MAY04	Tyco Electronics Harrisburg, PA 17105-3608
DIMENSIONS: mm 	TOLERANCES UNLESS OTHERWISE SPECIFIED: 0 PLC ± 1 PLC ±0.1 2 PLC ± 3 PLC ± 4 PLC ± ANGLES ±0°	NAME CAGE ASSEMBLY, 1X4 PRESS FIT, SFP	RESTRICTED TO
MATERIAL 	FINISH 	SIZE CAGE CODE DRAWING NO A 00779 C-1658744	SCALE 1:1 SHEET 1 OF 2 REV E1
CUSTOMER DRAWING			

LOC	DIST	REV	DESCRIPTION	DATE	DWN	APVD
GP	00		SEE SHEET 1			

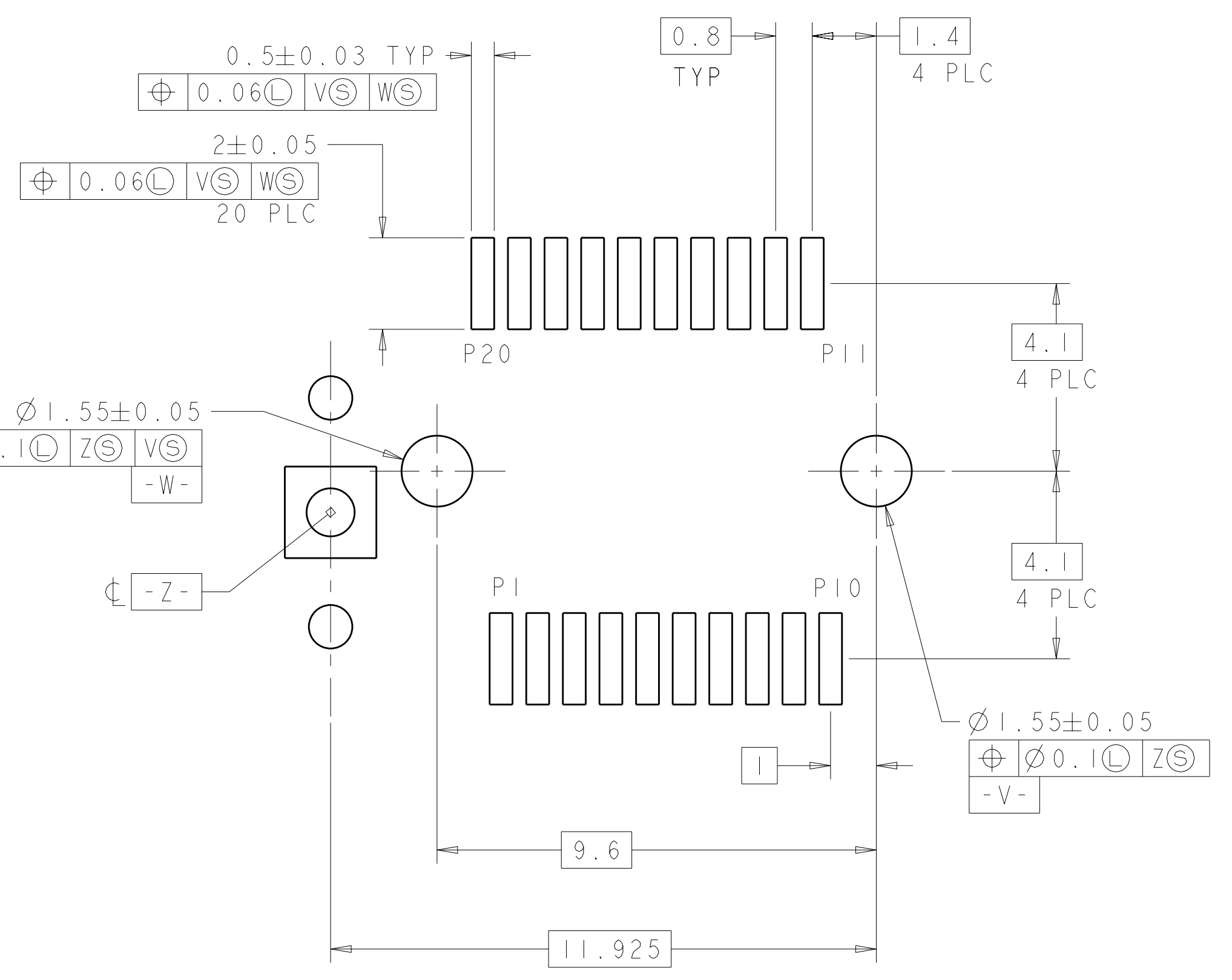
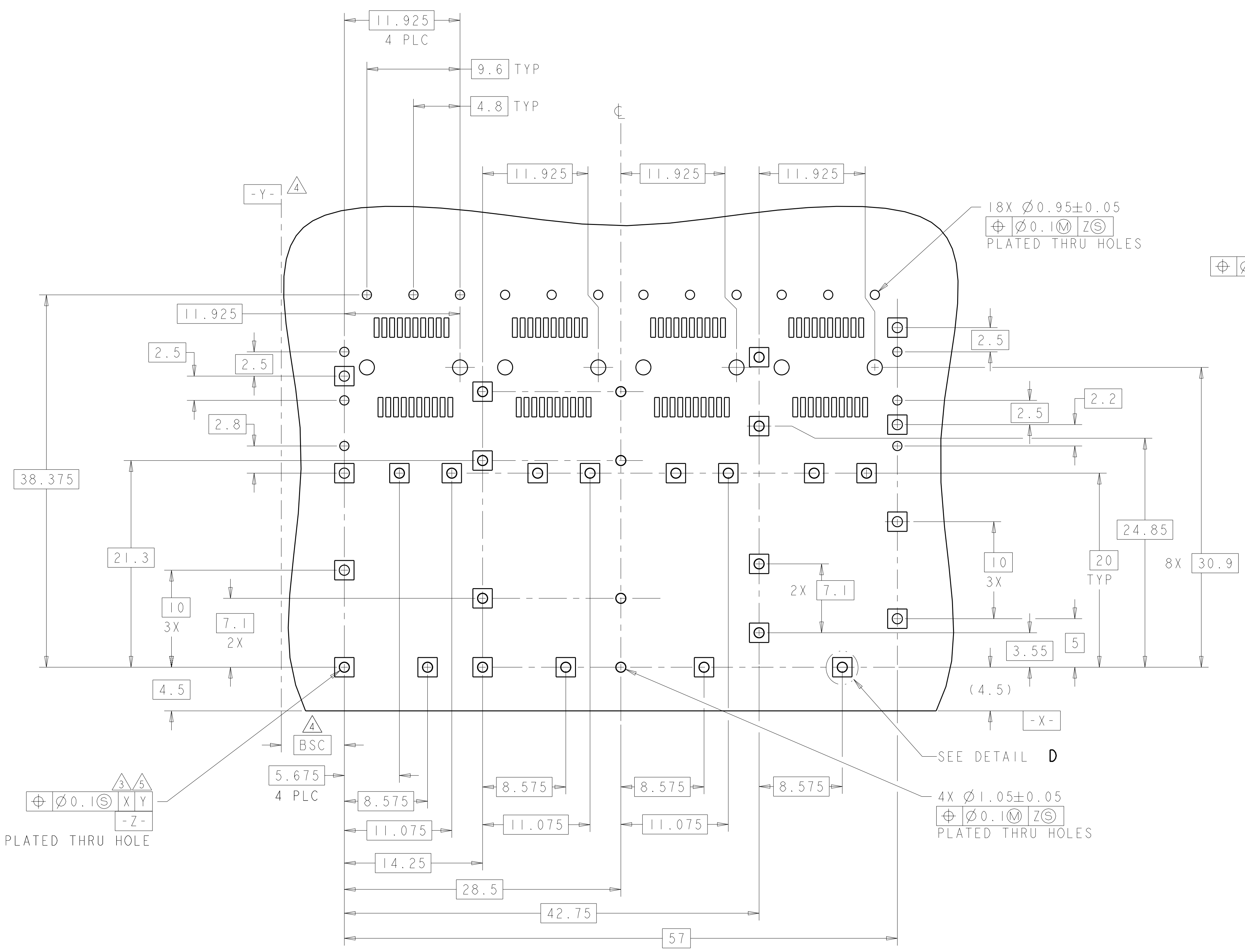

PT CONNECTOR  
 RECOMMENDED PCB  
 CONFIGURATION  
 SCALE 10:1

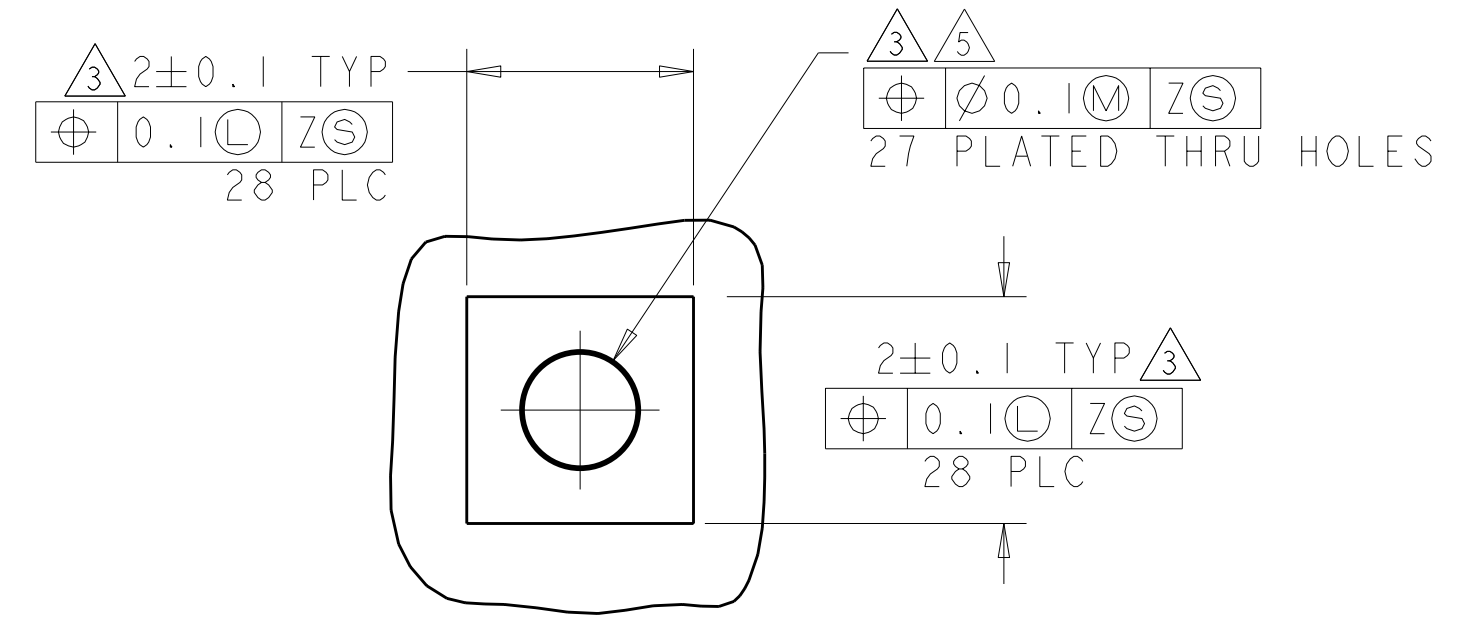

DETAIL D  
 SCALE 15:1

1658744-1  
 RECOMMENDED PCB  
 CONFIGURATION  
 SCALE 4:1

DIMENSIONS: mm 		TOLERANCES UNLESS OTHERWISE SPECIFIED: 9 PLC ± 1 PLC ±0.1 5 PLC ± 4 PLC ± ANGLES ±°		DWN M. SHIRK 04JUN03 CHK J. KOPPENHEFFER 06MAY04 APVD M. WALMSLEY 06MAY04 PRODUCT SPEC 108-1950 APPLICATION SPEC 114-13120 WEIGHT CUSTOMER DRAWING		Tyco Electronics Harrisburg, PA 17105-3608 NAME CAGE ASSEMBLY, 1X4 PRESS FIT, SFP SIZE CAGE CODE DRAWING NO RESTRICTED TO A11 00779 C=1658744 SCALE 1:1 SHEET 2 OF 2 REV E1	
-----------------------	--	--	--	--	--	---	--