

1-66361-4 Product Details

[Share](#) [Print](#) [Email](#)

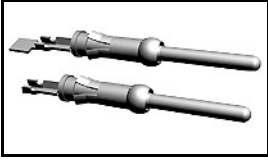

1-66361-4

TE Internal Number: 1-66361-4

 Active

[View 3D PDF](#)

Multimate

 Always EU RoHS/ELV Compliant
(Statement of Compliance)

Product Highlights:

- Contact Type = Pin
- Contact Classification = Signal
- Type III+ - Enhanced High Current Series
- High Current
- Gold (30) Contact Plating, Mating Area, Material

[View all Features](#)

Quick Links

- ▶ [Pricing & Availability](#)
- ▶ [Search for Tooling](#)
- ▶ [Product Feature Selector](#)
- ▶ [Contact Us About This Product](#)

[Add to My Part List](#)

[Request Sample](#)

[Find Similar Products](#)

[Buy Product](#)

Documentation & Additional Information

Product Drawings:

- [PIN ASSEMBLY, LOOSE PIECE, TYPE III+ \(PDF, English\)](#)

Catalog Pages/Data Sheets:

- [Signal Contacts \(PDF, English\)](#)
- [AMP Circular Connectors for Commercial Signal & Powe... \(PDF, English\)](#)

Product Specifications:

- None Available

Application Specifications:

- None Available

Instruction Sheets:

- None Available

CAD Files: (CAD Format & Compression Information)

- [2D Drawing \(DXF, Version G\)](#)
- [3D Model \(IGES, Version G\)](#)
- [3D Model \(STEP, Version G\)](#)

[List all Documents](#)

Additional Information:

- [Product Line Information](#)

Additional Product Images:

- [Line Drawing](#)

Related Products:

- [Tooling](#)

Product Features (Please use the Product Drawing for all design activity)

Product Type Features:

- Series = Type III+ - Enhanced High Current
- [Insulation Support](#) = Yes
- [Termination Method to Wire/Cable](#) = Crimp
- Wire/Cable Type = Discrete Wire
- Grade = Commercial

Electrical Characteristics:

- High Current = Yes

Termination Features:

- [Termination End Plating](#) = Gold Flash

Dimensions:

- Pin Diameter (mm [in]) = 1.57 [0.062]

Contact Features:

- Contact Type = Pin
- Contact Classification = Signal
- [Contact Plating, Mating Area, Material](#) = Gold (30)
- [Contact Base Material](#) = Brass
- [Contact Size](#) = 16

Industry Standards:

- [RoHS/ELV Compliance](#) = RoHS compliant, ELV compliant
- [Lead Free Solder Processes](#) = Not relevant for lead free process
- [RoHS/ELV Compliance History](#) = Always was RoHS compliant

Body Features:

- [Wire Range \(mm \[AWG\]\)](#) = 0.80-2.00² [18-14]
- Spring Material = Stainless Steel
- Used With = CPC Connectors, VDE Connectors

Conditions for Usage:

- [Accepts Wire Insulation Diameter, Range \(mm \[in\]\)](#)
= 2.03 – 2.54 [0.080 – 0.100]
- [Applies To](#) = Wire/Cable

Packaging Features:

- [Packaging Method](#) = Loose Piece
- Packaging Quantity = 1,000 Box/Carton

Other:

- Brand = AMP
- Comment = Overall insulation crimp diameter, including crimp barrel, must not exceed 3.18 [.125].

Corporate Information

[About TE](#)
[Investors](#)
[News Room](#)
[Supplier Portal](#)
[Careers](#)
[Terms & Conditions](#)
[Privacy Policy](#)

Quick Links

[Distributor Inventory](#)
[Product Cross Reference](#)
[Documents & Drawings](#)
[Product Compliance Support Center](#)
[Site Map](#)

Customer Support

[Email or Chat With Us](#)
[Find a Phone Number](#)
[Knowledge Base](#)
[Manage Your Account](#)

Keep Me Informed

THIS DRAWING IS UNPUBLISHED. RELEASED FOR PUBLICATION
 © COPYRIGHT - By - ALL RIGHTS RESERVED.

LOC		DIST		REVISIONS					
FT		0		P	LTR	DESCRIPTION	DATE	DWN	APVD
				K		REVISED PER ECO-12-012316	05JUL12	KH	MZ

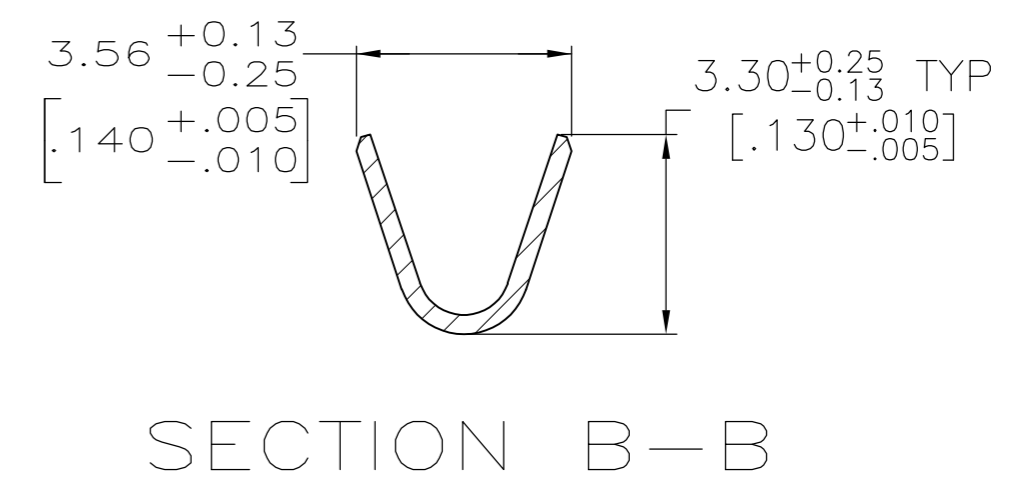
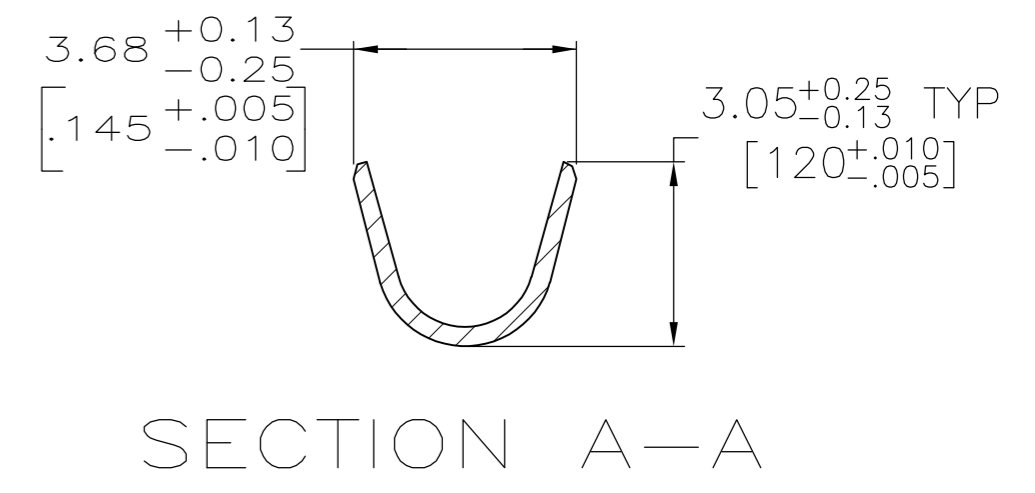
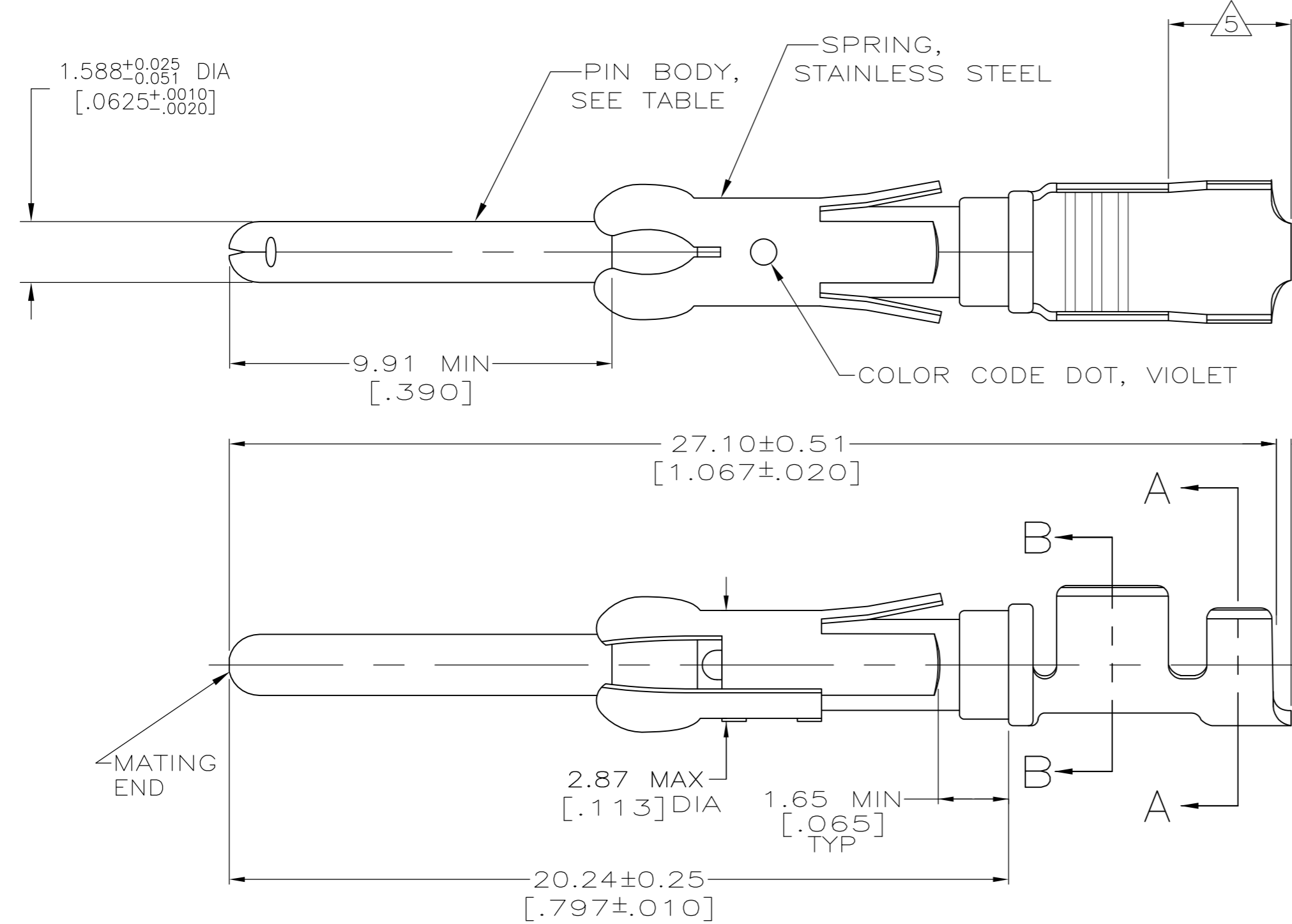

- 1 0.76µm [.000030] MIN PRECIOUS METAL PLATE ON MATING END FOR A LENGTH OF 5.08 [.200] MIN WITH 1.27µm [.000050] MIN NICKEL PLATE. GOLD FLASH ALL OVER. CONFORMS TO THE REQUIREMENTS OF TE CONNECTIVITY PRODUCT SPEC 108-10042, BASED ON EIA/ECA-364-1000.01A (CONTROLLED ENVIRONMENT APPLICATIONS).
- 2 0.76µm [.000030] MIN PRECIOUS METAL PLATE ON MATING END FOR A LENGTH OF 5.08 [.200] MIN WITH A UNIFORM GRADIENT TO 0.25µm [.000010] ON REMAINDER, OVER 1.27µm [.000050] MIN NICKEL PLATE. GOLD FLASH ALL OVER. CONFORMS TO THE REQUIREMENTS OF TE CONNECTIVITY PRODUCT SPEC 108-10042, BASED ON EIA/ECA-364-1000.01A (CONTROLLED ENVIRONMENT APPLICATIONS).
- 3 0.38µm [.000015] MIN GOLD PER MIL-G-45204 ON MATING END FOR A LENGTH OF 5.08 [.200] MIN WITH 1.27µm [.000050] MIN MATTE TIN PLATE IN WIRE CRIMP AREA, BOTH OVER 1.27µm [.000050] MIN NICKEL PER QQ-N-290.
- 4 1.27µm [.000050] MIN TIN-LEAD PER MIL-T-10727 OVER 1.27µm [.000050] MIN NICKEL PER QQ-N-290.
- 5 GOLD PLATING NOT REQUIRED IN THIS AREA.
- 6 WIRE RANGE 18-14 AWG.
- 7 INSULATION RANGE 2.03 [.080]-2.54 [.100] DIA.
- 8 0.38µm [.000015] MIN GOLD PER MIL-G-45204 ON MATING END FOR A LENGTH OF 5.08 [.200] MIN, 1.27µm [.000050] MIN TIN-LEAD PER MIL-T-10727 FOR A LENGTH OF 5.69 [.224] MIN ON OPPOSITE END, BOTH OVER 1.27µm [.000050] MIN NICKEL PER QQ-N-290 ON ENTIRE CONTACT.
- 9 1.27µm [.000050] MIN TIN PER MIL-T-10727 OVER 1.27µm [.000050] MIN NICKEL PER QQ-N-290.
- 10 0.76µm [.000030] MIN PRECIOUS METAL PLATE ON MATING END FOR A LENGTH OF 5.08 [.200] MIN WITH 1.27µm [.000050] MIN MATTE TIN PLATE IN WIRE CRIMP AREA, BOTH OVER 1.27µm [.000050] NICKEL PLATE. CONFORMS TO THE REQUIREMENTS OF TE CONNECTIVITY PRODUCT SPEC 108-10042, BASED ON EIA/ECA-364-1000.01A (CONTROLLED ENVIRONMENT APPLICATIONS).

STANDARD	9	CU-NI ALLOY	1-66359-9	1-66361-6
STANDARD	4	CU-NI ALLOY	1-66359-7	1-66361-5
STANDARD	1	CU-NI ALLOY	1-66359-6	1-66361-4
SMALL PACK	9	BRASS	1-66359-4	1-66361-3
STANDARD	9	BRASS	1-66359-4	1-66361-2
SMALL PACK	10	BRASS	66359-4	1-66361-1
SMALL PACK	4	BRASS	66359-2	1-66361-0
OBSOLETE	8	BRASS	1-66359-3	66361-9
OBSOLETE	1	PHOSPHOR BRONZE	1-66359-2	66361-8
OBSOLETE	4	PHOSPHOR BRONZE	1-66359-1	66361-7
STANDARD	10	BRASS	66359-4	66361-4
STANDARD	3	BRASS	66359-3	66361-3
STANDARD	4	BRASS	66359-2	66361-2
STANDARD	2	BRASS	66359-1	66361-1
PACKAGING	BODY FINISH	BODY MATERIAL	STRIP P/N REF	PART NUMBER

THIS DRAWING IS A CONTROLLED DOCUMENT.

DIMENSIONS: mm [INCHES]	TOLERANCES UNLESS OTHERWISE SPECIFIED: 0 PLC ± - 1 PLC ± - 2 PLC ± 0.13 [.005] 3 PLC ± - 4 PLC ± - ANGLES ± -	DWN L.SIPE 06/03/92 CHK W.LENKER 6-11-92 APVD G.STEINHAUER 7-8-92 PRODUCT SPEC - APPLICATION SPEC - WEIGHT -	NAME G.STEINHAUER SIZE A2 CAGE CODE 00779 DRAWING NO C=66361 RESTRICTED TO -
MATERIAL SEE CALLOUTS	FINISH SEE TABLE	CUSTOMER DRAWING	SCALE 8:1 SHEET 1 OF 1 REV K

TE Connectivity
 PIN ASSEMBLY, LOOSE PIECE, TYPE III+