

108-5124  
Rev. E4  
Product Specification  
(製品企規格)  
Dual Line Interlock Connector  
(D.L.I コネクタ)

Following first 9 pages are English version and last 9 pages are Japanese version. This top sheet is not part of the specification but explains both of English and Japanese versions are available.

このトップシートに続く最初の 9 ページは英語版で、その後の 9 ページは日本語版です。  
このトップシートは、規格には含まれませんが、英語、日本語両方があることを説明しています。

108-5124

NUMBER

Customer  
ReleaseAMP SECURITY  
CLASSIFICATION

PRINT DIST

108-5124  
Product Specification  
Dual Line Interlock Connector  
(D.L.I. Connector)

1. Scope:

This specification covers performance requirements and test methods for Dual Line Interlock Connector for wire-to-board termination (D.L.I. connector),

2. Product Descriptions:

Dual Line Interlock Connector comprises cap housing connector with contact posts preloaded in a 4.6mm distance dual row disposition with 3.0mm center line spacing mounted on PCB, and plug housing that capsulates wire-crimped receptacle contacts to mate with posts. Two types of connectors, vertical and horizontal ones are available for cap housing. The bottom end of the post contact is soldered on PCB.

This interconnection system is suitable for wire-to-board termination of electronic control circuits for automotive use and other electronic system equipment. The cap housing is secured on printed circuit board with the use of two 3mm dia. screws.

3. Patent:

Patent pending (No. 147672, Utility Model, Japan)

4. Definitions of Component:

4.1 Contact:

4.1.1 Receptacle Contact:

A wire crimping female contact for mating with post contact in housing.

4.1.2 Post Contact:

A male post contact to mate with receptacle contact in the form of cap housing assembly after being mounted on cap housing.

4.2 Cap Connector Assembly:

A connector assembly consisting of cap housing and post contacts, used for PCB termination after mounting on it.

4.3 Plug Connector Assembly:

A connector assembly consisting of plug housing and receptacle contacts. Plug connector assembly completes termination by mating with cap connector assembly.

Two types of plug housings are available, being classified by the type of contact locking in position.

**Standard Type:** Contacts are locked in contact position by the locking lance provided on the contact.

**Double Locking Type:** After contacts are locked by the contact locking lance, double locking is made by inserting locking plate into the housing cavity from the rear (wire side) of housing. Two locking plates are used for one connector. Locking plate cannot be applied to standard type connector.

DR <i>[Signature]</i> 6-5-84	Tyco Electronics Japan G.K.		
CHK <i>[Signature]</i> 6-5-84	LOG J	NO 108-5124	REV E4
APP <i>[Signature]</i> 6/5/84	NAME Product Specification		
SHEET 1 OF 9	Dual Line Interlock Connector (D.L.I. Connector)		

NUMBER 108-5124  
 AMP SECURITY CLASSIFICATION  
 Customer Release

5. Material and Finish:

5.1 Receptacle Contact:

Receptacle contact shall be made of 0.3mm thick brass, conforming to C-2600R-H of JIS H 3100 or equivalent and finished with 0.8µm minimum tin-plating.

5.2 Post Contact:

Post contact shall be made of 0.4mm square phosphor bronze, conforming to C 5101R-H of JIS H 3110 and finished with tin-plating 0.8µm thick minimum tin-plating.

5.3 Housing:

Housing is made of molded 6/6 Nylon resin (LEONA\* 1300S, manufactured by Asahi Chemical Industries Co. Ltd.), conforming to UL 94V-2.

6. Quality Assurance Provisions:

Unless otherwise specified, all the tests shall be performed in accordance with the test methods specified in Para. 8 and test sequence specified in Table 2. The tested products shall show the designated performance capability conforming to the requirements specified in Table 1, Para. 7.2.

6.1 Test Conditions:

Unless otherwise specified, all the tests shall be performed under any combination of the following test conditions.

Room Temperature: 15 - 35°C  
 Relative Humidity: 45 - 75%  
 Atmospheric Pressure: 86.7-107kPa(650-800mmHg)

6.2 Temperature Rating:

Temperature rating of the connectors in mated condition shall be within the range of -30°C and 105°C. This temperature includes ambient temperature and temperature increase produced by the operating energized current.

6.3 Applicable Wire Sizes:

The wires used for terminating receptacle contact shall be of the sizes and composition as specified below:

Wire Size: 0.56 - 0.3mm<sup>2</sup> (AWG #20-#22) Stranded one wire only  
 Insulation Range: 2.4mm - 1.4mm in diameter

7. Performance:

7.1 Rating:

7.1.1 Voltage Rating: 250V AC or 350V DC Maximum

7.1.2 Current Rating: 5A Continuous, Maximum

SHEET		 Tyco Electronics Japan G.K.		
2 OF 9	LOC	NO	108-5124	REV.
	J	A		E4
NAME Product Specification Dual Line Interlock Connector (D.L.I. Connector)				

NUMBER 108-5124

Customer Release  
AMP SECURITY CLASSIFICATION

**7.2 Performance Requirements:**

When tested in accordance with the test methods specified in Para. 8, the performance requirements specified in Table 1 shall be met.

Para-graph Number	Test Item	Specified Requirements	Test Method Para-graph
7.2.1	Termination Resistance (Low Level)	6 mΩ max. (Initial) 12 mΩ max. (Final)	8.1
7.2.2	Insulation Resistance	500 MΩ min. at (500V DC)	8.2
7.2.3	Dielectric Strength	Must withstand 1000V AC for 1 minute without showing abnormalities.	8.3
7.2.4	Temperature Rising	65°C increase over ambient temperature max.	8.4
7.2.5	Contact Retention Force	49N min. Standard Type	8.5
		98N min. Double Locking Type	
7.2.6	Crimp Tensile Strength	78N min. for 0.56mm <sup>2</sup> (#20 AWG) wire	8.6
		49N min. for 0.3mm <sup>2</sup> (#22AWG) wire	
7.2.7	Post Retention Force	19.6N min. Initial (Applicable to vertical type only)	8.7
7.2.8	Housing Locking Retention Force	59N min.	8.8
7.2.9	Vibration	No electrical discontinuity greater than 10 microseconds shall occur during test. Final termination resistance (Low Level) shall be 12 mΩ max.	8.9
7.2.10	Humidity (Steady State)	Connector shall be free from defects such as cracks, blister etc. that are detrimental to connector function. Final termination resistance (Low Level) shall be 12 mΩ max.	8.10
7.2.11	Sulfuric Acid Gas Resistibility	Connector shall be free from defects such as cracks, blister etc. that are detrimental to connector function. Final termination resistance (Low Level) shall be 12 mΩ max.	8.11
7.2.12	Temperature Cycling	Connector shall be free from defects such as cracks, blister etc. that are detrimental to connector function. Final termination resistance (Low Level) shall be 12 mΩ max.	8.12
7.2.13	Current Cycling	Final termination resistance (low level) shall be 12 mΩ max.	8.13
7.2.14	Solderability	More than 95% of tested area must be covered with fresh, uniformly working solder. This is applied to plated surfaces of contact only.	8.14
7.2.15	Contact Insertion & Extraction Force	Insertion Force: 5.9N max. (Initial) Extraction Force: 98mN min. (Initial)	8.15

Table 1 ( To be continued)

SHEET		 <b>Tyco Electronics</b> Tyco Electronics Japan G.K.	
3 OF 9			
LOC	A	NO	108-5124
REV	E4		
NAME Product Specification Dual Line Interlock Connector (D.L.I. Connector)			

7.2 Performance Requirements (Continued):

NUMBER 108-5124  
 AMP SECURITY CLASSIFICATION Customer Release

Para-graph Number	Test Item	Specified Requirements				Test Method Para-graph
		No. of Pos.	Measured Cycle(s) at:	Insertion Force N	Extraction Force N	
7.2.16	Connector Insertion/Extraction Force	20	Initial	118 max.	24.5 min.	8.16
			50th. Cycle	118 max.	19.6 min.	
		16	Initial	98 max.	19.6 min.	
			50th. Cycle	98 max.	14.7 min.	
		12	Initial	68 max.	14.7 min.	
			50th. Cycle	68 max.	12 min.	
8	Initial	49 max.	9.8 min.			
	50th. Cycle	49 max.	7.8 min.			
7.2.17 (REF.)	Salt Spray	Connector shall be free from defects such as cracks, blister, etc. that are detrimental to connector functions. Final termination resistance (low level) shall be 50 mΩ max.				8.17

Table 1 (End)

8. Test Methods:

8.1 Termination Resistance:

Contact-loaded and mated pair of connectors are subject to testing by applying closed circuit current of 50mA at open circuit voltage of 50mV flowing through the circuit as shown in Fig. 1. Low level termination resistance is calculated from the millivolt drop reading after deducting the resistance of 75mm-long wire used for termination. The probing point on post connector side must be 1 mm apart from the bottom surface of housing, and measurements shall be done in the manner one after one to cover all the connector positions.

8.2 Insulation Resistance:

Contact-loaded and mated pair of connectors are subject to testing by applying test potential of 500V DC between the adjacent contacts and between the contacts and the ground.

8.3 Dielectric Strength:

Contact-loaded and mated pair of connectors are subject to testing by applying test potential of 1000V AC for 1 minute between the adjacent contacts and between the contacts and the ground.

SHEET		 <b>Tyco Electronics</b> Tyco Electronics Japan G.K.		
4 OF 9	LOC	A	NQ 108-5124	REV E4
NAME Product Specification Dual Line Interlock Connector (D.L.I. Connector)				

## 8.4 Temperature Rising:

Contact-loaded and mated pair of connectors are subject to testing by applying test current of 5A DC to the circuits. The temperature rising shall be measured by probing at the wire crimp by using thermocouple.

## 8.5 Contact Retention Force:

Insert contact which is crimped on an approximately 75mm-long, 0.5 - 0.56mm<sup>2</sup> wire, into the connector housing, and after securely fastened on a tensile testing machine, apply an axial pull-off load to the end of crimped wire by operating the head to travel with the speed at a rate of 100mm a minute. Contact retention force is determined when the wire is broken or contact is dislodged from housing.

## 8.6 Crimp Tensile Strength

Securely fasten a wire-crimped contact on a tensile testing machine and apply an axial pull-off load to the crimped wire by operating the head to travel with the speed at a rate of 100mm a minute. Crimp tensile strength is determined when the wire is broken or is pulled off from the wire crimp.

## 8.7 Post Retention Force:

Accept the post connector with the test fixture specified as shown in Fig. 3. and apply an axial push-in load to the head of post contact vertically to dislodge from the mounted position. The force required to dislodge the post shall be measured.

## 8.8 Housing Locking Mechanism Retention Force:

Contact-loaded and mated pair of connectors are subject to testing by applying an axial load to separate the locked connectors. The force required to separate the connectors with or without damage of locking mechanism shall be measured and recorded.

## 8.9 Vibration:

Contact-loaded and mated pair of connectors are subject to testing after all the contacts series wired. The connectors are secured on the vibratile table, and sweeping vibration to reciprocate from 10 to 55 Hz. changing one cycle a minute, with the accelerated velocity of 43m/s<sup>2</sup> (4.4g) is applied to it. During the vibration, closed circuit current of 0.1A at open circuit voltage of 13V DC is applied to the circuit, and monitored for electrical discontinuity greater than 10 microsecond taking place in the circuit. Test duration shall be 2 hours each for three axial directions of X, Y and Z, totally 6 hours.

## 8.10 Humidity:

Contact-loaded and mated pair of connectors are subject to testing by exposing under humidity conditioning in the test chamber, where relative humidity ranging 90 - 95% at the temperature of 40°C is maintained. After exposing for 96 hours, the sample shall be taken out from the test chamber and reconditioned in the room temperature for 1 hour before undergoing subsequent measurements.

SHEET		 <b>Tyco Electronics</b> Tyco Electronics Japan G.K.	
5 OF 9			
LOC	A	NO	108-5124
	J		REV E4
NAME Product Specification Dual Line Interlock Connector (D.L.I. Connector)			

8.11 Sulfurous Acid Gas Resistibility:

Contact-loaded and mated pair of connectors are subject to exposure under sulfurous acid gas atmosphere of 10 p.p.m. with relative humidity of 90% minimum for 48 hours.

8.12 Temperature Cycling:

Contact-loaded and mated pair of connectors are subject to exposure under 5 cycles of temperature conditioning in the oven, each cycle consisting of at  $-30 \pm 2^{\circ}\text{C}$  for 3 hours, followed by at  $25 \pm 5 \text{ }^{+10}_{-5} \text{ }^{\circ}\text{C}$  for 30 minutes, then at  $80 \pm 2^{\circ}\text{C}$  for 3 hours, and reconditioned at  $25 \pm 5 \text{ }^{+10}_{-5} \text{ }^{\circ}\text{C}$  for 30 minutes. After completion of test cycles, subsequent measurement shall be made.

8.13 Current Cycling:

Contact-loaded and mated pair of connectors are subject to testing by applying 50 cycles of current cycling test conditioning, each cycle consisting of energizing 3A DC for 45 minutes followed by de-energizing for 15 minutes. After completion of test conditioning, subsequent measurement shall be performed.

8.14 Solderability:

Dip soldering area of post contacts of cap connector in flux (rosin solution in methanol) for 5 - 10 seconds, then dip into the melted solder (60% tin, 40% lead), temperature of which is controlled at  $230^{\circ}\text{C} \pm 5^{\circ}\text{C}$  for  $3 \pm 0.3$  seconds. After immersion, soldered area shall be visually inspected with the aid of X10 magnifying glass.

8.15 Contact Insertion/Extraction Force:

Securely fasten a pair of contacts on tensile testing machine in the manner that they mate and unmate as the head is operated with the speed at a rate of 100 mm a minute. The force required to mate and unmate with the post used for cap housing, shall be measured and recorded.

8.16 Connector Insertion/Extraction Force:

Securely fasten contact-loaded cap housing connector on tensile testing machine, and the counterpart plug housing connector to be fixed on the head in the manner to mate and unmate as the head is operated. Connector insertion/extraction force is tested by operating the head to travel with the speed at a rate of 100mm a minute. The force required to mate and unmate the connectors is measured and recorded. For this test, locking mechanism must be kept not set in effect.

8.17 Salt Spray:

Contact-loaded and mated pair of connectors are subject to exposure under spray of 5% salt solution at  $35^{\circ}\text{C}$  for 48 hours. After test duration, lense the connector in the tap water, and have it dried in the room temperature for 1 hour before undergoing subsequent measurement.

SHEET		Tyco Electronics Japan G.K.	
6 OF 9	Loc J A	NO 108-5124	REV E4
NAME Product Specification Dual Line Interlock Connector (D.L.I. Connector)			



108-5124

NUMBER

Customer Release

AMP SECURITY CLASSIFICATION

9. Test Sequence:

Tests shall be performed in the sequence specified in Table 2, by each sample grouped.

Test Method Paragraph	Test Item	Sample Group													
		1	2	3	4	5	6	7	8	9	10	11	12	13	14
8.1	Termination Resistance (Low Level)						① ③	① ③	① ③	① ③	① ③				① ③
8.2	Insulation Resistance	① ④													
8.3	Dielectric Strength	② ⑤													
8.4	Temperature Rising		①												
8.5	Contact Retention Force	⑥													
8.6	Crimp Tensile Strength			①											
8.7	Post Retention Force				①										
8.8	Housing Locking Mechanism Retention Force					①									
8.9	Vibration						②								
8.10	Humidity	③						②							
8.11	Sulfurous Acid Gas Resistibility								②						
8.12	Temperature Cycling								②						
8.13	Current Cycling									②					
8.14	Solderability										①				
8.15	Contact Insertion/Extraction Force											①			
8.16	Connector Insertion/Extraction Force												①		
8.17	Salt Spray														②

Table 2

SHEET		 Tyco Electronics		Tyco Electronics Japan G.K.	
7 OF 9		LOC	A	NO	108-5124
				REV	E4
NAME Product Specification Dual Line Interlock Connector (D.L.I. Connector)					

AMP J-523



Vertical Type Connector:

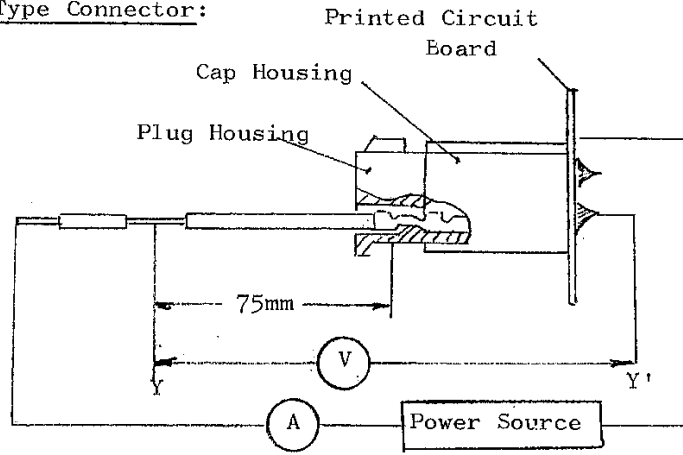

Horizontal Type Connector:

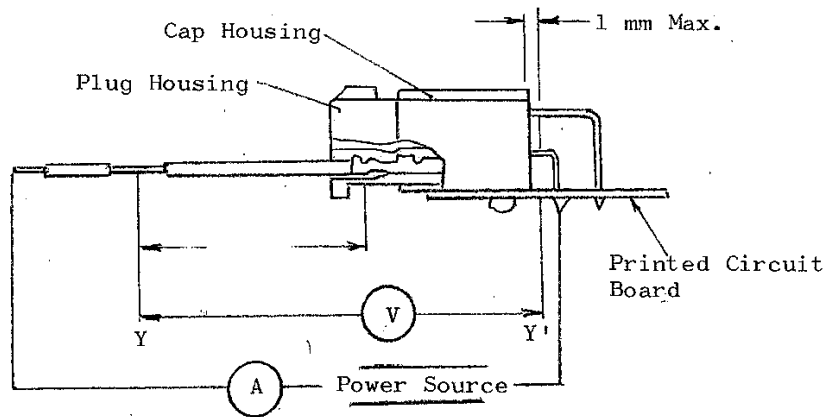
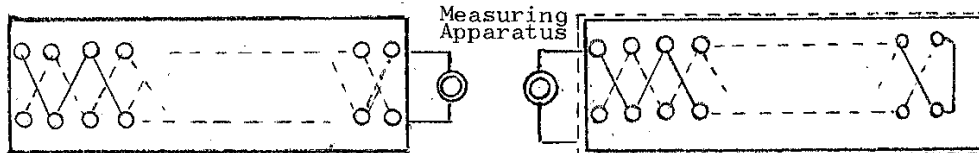

Fig 1



Measurement between  
Adjacent Contacts

Wrap connector with metallic foil.  
Metallic foil must be kept 5mm  
apart from the surface of connector  
contacts.

Measurement between Contacts  
and the Ground

Fig. 2

SHEET		Tyco Electronics		Tyco Electronics Japan G.K.	
8 OF 9	LOC J A	NO 108-5124	REV E4		
NAME Product Specification Dual Line Interlock Connector (D.L.I. Connector)					

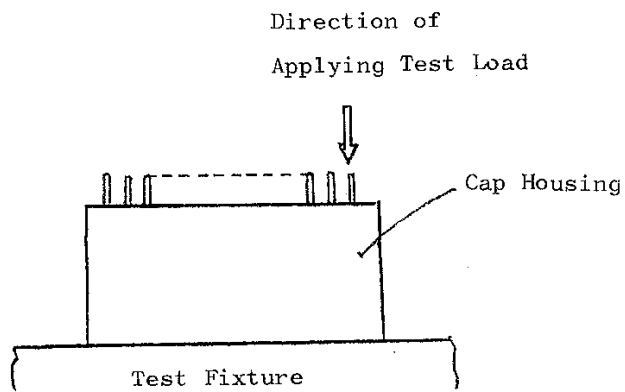

Fig. 3

SHEET		Tyco Electronics		Tyco Electronics Japan G.K.	
9	OF	9	LOC	A	NO 108-5124
			REV.		E4
NAME Product Specification Dual Line Interlock Connector (D.L.I. Connector)					

一般顧客用 管理基準	<b>社 内 標 準</b> (製 造 標 準)	<b>Tyco Electronics</b> タイコ エレクトロニクス ジャパン合同会社	適用事業所 全 社
---------------	-----------------------------	--	--------------

## 製 品 規 格

108-5124

デュアル・ライン・インターロック・コネクタ

(D.L.I. CONNECTOR)

1. 概 要

本コネクタは二列の配列で、列間 4.6 mm 各列の極間ピッチ 3 mm で構成され、ロック機構のある基板対電線の接続方式で基板に対する電線の引き出し方向により水平接続型と垂直接続型がある。

基板側はキャップ・アセンブリのポスト脚部をはんだ付けする。電線側は圧着されたりセクタクル・コンタクトをそれぞれの極数のプラグ・ハウジングに挿入しそれぞれキャップアセンブリに嵌合する。

2. 適用範囲

本規格はタイコ エレクトロニクス アンプレで製造される基板対電線接続型デュアル・ライン・インターロック・コネクタ (D.L.I. コネクタ) の全ての製品について適用される。

3. 特 許

本製品は実用新案申請済 (No. 147672 他) である。

4. 構成部品の名称と意味

## 4.1 コンタクト

リセクタクル・コンタクトの通称とし、雌側接触子で電線を圧着して使用する。

## 4.2 ポ ス ト

雄側接触子の意味で、キャップ・ハウジングに組立てられてキャップ・アセンブリとして使用される。

## 4.3 キャップ・アセンブリ

キャップ・ハウジングとポストを組立てたもので、基板に固定して使用する。

作成： 2/26/80 K. Aoyama	分類： 製 品 規 格
検閲： cshie 2/26/80	コード： 108-5124
承認： cshie 2/26/80	改訂 E4 名称： D.L.I. コネクタ

配布

昭和 53 年 11 月 6 日 制 定

1 頁  
9 頁中

## 4.4 プラグ・ハウジング

電線圧着済のコンタクトを挿着するハウジングでキャップ・アセンブリと一対で一組のコネクタとなる。

プラグ・ハウジングはコンタクトの固定方式により次の2種類がある。

〔標準型〕 コンタクトに設けられたランスによりプラグ・ハウジングに固定する。

〔二重ロック型〕 コンタクトのランスにより固定した後ハウジングの後部（電線引き出し側）からロッキングプレートを挿入して二重に固定する。

プラグ・ハウジング1枚に対してロッキング・プレート2枚で1組となる（このロッキング・プレートは標準型プラグ・ハウジングには使用できない）。

## 5. 使用材料・表面処理

## 5.1 コンタクト

(1) 材質； 黄銅  $t = 0.3$  (JIS H 3100 C2600R-H相当品)

(2) 表面処理； 錫メッキ済  $0.8\mu$  以上

## 5.2 ポスト

(1) 材質； りん青銅  $0.64^{\square}$  (JIS H 3110 C5101R-H相当品)

(2) 表面処理； 錫めつき済  $0.8\mu$  以上

## 5.3 ハウジング

(1) 材質； 66ナイロン, UL 94V-2

## 6. 品質保証条件

本製品規格は完全に管理された製品について品質を保証する。

## 6.1 試験環境

試験は下記に示す環境条件のもとで行うこと。

温度  $15^{\circ}\text{C} \sim 35^{\circ}\text{C}$

湿度  $45\% \sim 75\%$

気圧(水銀柱)  $86.7 - 107\text{kPa}$  ( $650 - 800\text{mmHg}$ )

## 6.2 使用温度範囲(嵌合状態)

$-30^{\circ}\text{C} \sim +105^{\circ}\text{C}$  (周囲温度+通電による温度上昇含)

## 6.3 適用電線範囲

$0.56 \sim 0.3\text{mm}^2$  (AWG# 20~# 22) 撚線1本圧着

被覆外径  $\phi 2.4\text{mm} \sim \phi 1.4\text{mm}$

分類： 製品規格	標準の名称： D.L.I. コネクタ	標準のコード： 108-5124	改訂	2頁
			E4	9頁中

## 7. 性 能

## 7.1 定 格

- (1) 電 圧 ; 最大 AC 250V, DC 350V  
 (2) 電 流 ; 最大連続 5A

## 7.2 一般性能

第8項「試験方法」に基づき試験した結果、第1表の性能を満足すること。

表 1

項 番	試 験 項 目	規 格 値	試験方法 項 番
7.2.1	ローレベル抵抗	初期値：6mΩ以下 試験後：12mΩ以下	8.1
7.2.2	絶 縁 抵 抗	500MΩ以上(DC 500V)	8.2
7.2.3	耐 電 圧	AC 1000V, 1分間で異常なきこと。	8.3
7.2.4	温 度 上 昇	65℃以下	8.4
7.2.5	コンタクト保持力		8.5
	標準型	49N 以上	
	二重ロック型	98N 以上 (コンタクトロックのみの時49N 以上)	
7.2.6	圧着部引張強度	AWG 20(0.56mm <sup>2</sup> ) 78N 以上 AWG 22(0.3mm <sup>2</sup> ) 49N 以上	8.6
7.2.7	ポスト保持力	初期 19.6N以上(垂直接続型のみ適用)	8.7
7.2.8	ハウジングロック強度	59N 以上	8.8
7.2.9	振 動	振動中10μsecを越える不連続導通を生じないこと。ローレベル抵抗は12mΩ以下。	8.9
7.2.10	耐 湿 性 (定常状態)	割れ、フクレ、その他機能を損う欠陥のないこと。ローレベル抵抗は12mΩ以下。	8.10
7.2.11	亜硫酸ガス性	割れ、フクレ、その他機能を損う欠陥のないこと。ローレベル抵抗は12mΩ以下。	8.11
7.2.12	温度サイクル	割れ、フクレ、その他機能を損う欠陥のないこと。ローレベル抵抗は12mΩ以下。	8.12

分類：	製品規格	標準の名称：	D.L.I. コネクタ	標準のコード：	108-5124	改訂	3 頁
						E4	9 頁中

表 1 ( 続き )

項番	試験項目	規格値	試験方法 項番																																		
7.2.13	電流サイクル	ローレベル抵抗 12 mΩ以下	8.13																																		
7.2.14	はんだ付性	はんだヌレ 95%以上(但しめっき面のみ)	8.14																																		
7.2.15	コンタクト単体挿抜力	<table border="1"> <thead> <tr> <th>ゲージ</th> <th>挿入力</th> <th>引抜力</th> </tr> </thead> <tbody> <tr> <td>初回</td> <td>5.9 N 以下</td> <td>98mN 以上</td> </tr> </tbody> </table>	ゲージ	挿入力	引抜力	初回	5.9 N 以下	98mN 以上	8.15																												
ゲージ	挿入力	引抜力																																			
初回	5.9 N 以下	98mN 以上																																			
7.2.16	コネクタ挿抜力	<table border="1"> <thead> <tr> <th rowspan="2">極数</th> <th rowspan="2">回数</th> <th>挿入力</th> <th>引抜力</th> </tr> <tr> <th>N 以下</th> <th>N 以上</th> </tr> </thead> <tbody> <tr> <td rowspan="2">20</td> <td>初回</td> <td>118</td> <td>24.5</td> </tr> <tr> <td>50回</td> <td>118</td> <td>19.6</td> </tr> <tr> <td rowspan="2">16</td> <td>初回</td> <td>98</td> <td>19.6</td> </tr> <tr> <td>50回</td> <td>98</td> <td>14.7</td> </tr> <tr> <td rowspan="2">12</td> <td>初回</td> <td>68</td> <td>14.7</td> </tr> <tr> <td>50回</td> <td>68</td> <td>12</td> </tr> <tr> <td rowspan="2">8</td> <td>初回</td> <td>49</td> <td>9.8</td> </tr> <tr> <td>50回</td> <td>49</td> <td>7.8</td> </tr> </tbody> </table>	極数	回数	挿入力	引抜力	N 以下	N 以上	20	初回	118	24.5	50回	118	19.6	16	初回	98	19.6	50回	98	14.7	12	初回	68	14.7	50回	68	12	8	初回	49	9.8	50回	49	7.8	8.16
極数	回数	挿入力			引抜力																																
		N 以下	N 以上																																		
20	初回	118	24.5																																		
	50回	118	19.6																																		
16	初回	98	19.6																																		
	50回	98	14.7																																		
12	初回	68	14.7																																		
	50回	68	12																																		
8	初回	49	9.8																																		
	50回	49	7.8																																		
7.2.17 参考	塩水噴霧	割れ、フクレ、その他機能を損う欠陥のないこと。ローレベル抵抗は 50 mΩ以下。	8.17																																		

## 8. 試験方法

### 8.1 ローレベル抵抗

第1図の如くコネクタを嵌合した状態で、開放電圧 50 mV 以下、短絡電流 50 mA 以下の回路で測定し、電線導体抵抗 75 mm 分を差し引いて算出する。

なお、測定は1極ずつ行うものとする。

### 8.2 絶縁抵抗

コネクタを嵌合した状態で各々の隣接するコンタクト相互間及びコンタクト対アース間を測定する。測定電圧は DC 500 V とする。

分類： 製品規格	標準の名称： D.L.I. コネクタ	標準のコード： 108-5124	改訂 E4	4 頁 9 頁中
-------------	-----------------------	---------------------	----------	-------------

## 8.3 耐電圧

コネクタを嵌合した状態で第2図の如く隣接するコンタクト相互間及びコンタクト対アース間に AC 1000 V を1分間印加する。

## 8.4 温度上昇

コネクタを嵌合した状態で直列に結線し、測定場所はコンタクト圧着部分を熱電対法にて測定する(通電電流 DC 5A)。

## 8.5 コンタクト保持力

ハウジングに約 75mm の長さ、0.5 ~ 0.56 mm<sup>2</sup> の断面積の電線を圧着したコンタクトが挿着されたコネクタをショッパー引張試験機に取り付け、電線を軸方向へ毎分約 100mm の速度で引張り、コンタクトがハウジングから抜けた時の荷重を測定する。

## 8.6 圧着部引張強度

電線を圧着したコンタクトをショッパー引張試験機に取り付け、電線を軸方向に毎分約 100 mm の速度で引張り最大荷重を測定する。

## 8.7 ポスト保持力

キャップ・アセンブリを第3図の如く底面を上にしてポスト先端を軸方向に垂直にフォースゲージで押して最大値を測定する。なお、測定は1本ずつ行うこと。

## 8.8 ハウジングロック強度

コネクタを嵌合しロック機構の作用した状態で一方を固定し、他方を軸方向に毎分約 100 mm の速度で引張り、最大荷重を測定する。

## 8.9 振動

コネクタを嵌合し、プリント基板に固定した試料を直列回路になるよう結線し振動試験機に取り付け、開放電圧 DC 13 V、短絡電流 0.1 A を通電する。

振動方向： X, Y, Z 方向 各2時間

振動加速度： 43m/s<sup>2</sup> (4.4G) 一定

振動周波数： 10 ~ 200 Hz 往復 1分間

## 8.10 耐湿性

嵌合状態の試料を、湿度 90~95%、温度 40℃ の環境中で連続 96 時間放置後、室温中に 1 時間放置してから測定する。

分類：	製品の規格	標準の名称：	D. L. I. コネクタ	標準のコード：	108-5124	改訂	5 頁
						E4	9 頁中



## 8.11 亜硫酸ガス性

嵌合状態の試料をガス濃度 10 PPM, 湿度 90% 以上の環境中で連続 48 時間放置後測定する。

## 8.12 温度サイクル

嵌合状態の試料を  $-30 \pm 2 \text{ } ^\circ\text{C} / 3 \text{ 時間} \rightarrow 25 \pm 10 \text{ } ^\circ\text{C} / 30 \text{ 分} \rightarrow 80 \pm 2 \text{ } ^\circ\text{C} / 3 \text{ 時間} \rightarrow 25 \pm 10 \text{ } ^\circ\text{C} / 30 \text{ 分}$  を 1 サイクルとした環境中に 5 サイクル放置後測定する。

## 8.13 電流サイクル

嵌合状態の試料に DC 3A を 45 分間通電, 15 分間切断の状態を 1 サイクルとし, 50 サイクル行った後測定する。

## 8.14 はんだ付性

キャップ・アセンブリのポストのはんだ付部分をフラックス(ロジンのメタノール溶液)に 5~10 秒浸漬した後,  $230 \text{ } ^\circ\text{C} \pm 5 \text{ } ^\circ\text{C}$  のはんだ(錫 60%, 鉛 40%)槽中に,  $3 \pm 0.5$  秒間浸漬し, 倍率約 10 倍で観察する。

## 8.15 コンタクト単体挿抜力

コンタクトを引張試験機に取り付けキャップハウジングに使用されているポストを用いて軸方向に毎分 100mm の速度で操作し測定する。

## 8.16 コネクタ挿抜力

キャップ・アセンブリを引張試験機に取り付け, コンタクトを挿着したプラグ・ハウジングを軸方向に毎分 100mm の速度で操作し測定する。  
ハウジングのロック機構は作用させないで行う。

## 8.17 塩水噴霧

嵌合状態の試料を塩水濃度 5%, 温度  $35 \text{ } ^\circ\text{C}$  の環境中で連続 48 時間放置し, 塩の堆積物を水洗いした後, 1 時間放置してから測定する。

分類:	製品の規格	標準の名称:	D. L. I. コネクタ	標準のコード:	108-5124	改訂	6 頁
						E4	9 頁中

## 9. 試験順序

試験は各試料をグループ別に分け、表2の順序で実施すること。

表 2

試験方法	試験項目	試験グループ番号													
		1	2	3	4	5	6	7	8	9	10	11	12	13	14
8.1	ローレベル抵抗						① ③	① ③	① ③	① ③	① ③				① ③
8.2	絶縁抵抗	① ④													
8.3	耐電圧	② ⑤													
8.4	温度上昇		①												
8.5	コンタクト保持力	⑥													
8.6	圧着部引張強度			①											
8.7	ポスト保持力				①										
8.8	ハウジングロック強度					①									
8.9	振動						②								
8.10	耐湿性	③						②							
8.11	亜硫酸ガス性								②						
8.12	温度サイクル									②					
8.13	電流サイクル										②				
8.14	はんだ付性											①			
8.15	コンタクト単体挿抜力												①		
8.16	コネクタ挿抜力													①	
8.17	塩水噴霧														②

分類：

製品規格

標準の名称：

D.L.I. コネクタ

標準のコード：

108-5124

改訂

E4

7頁

9頁中

垂直型の場合

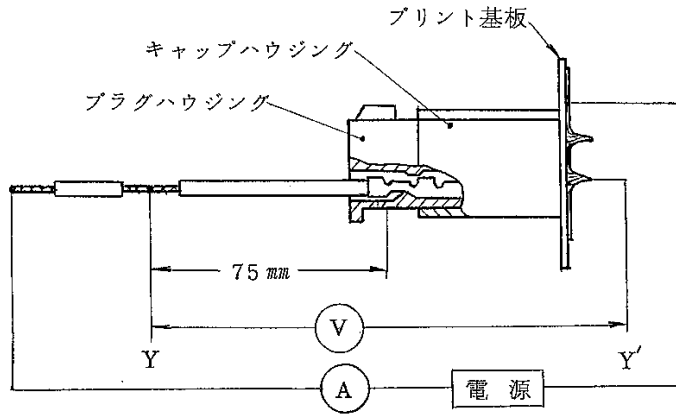

水平型の場合

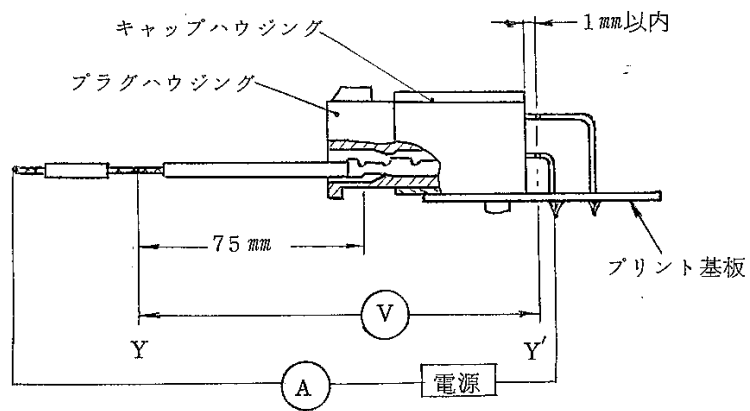

第 1 図

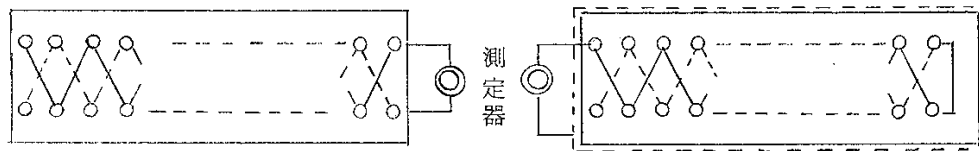

ハウジング表面に導体箔を巻く

〔注〕 導体箔は露出しているコンタクトから 5 mm 以上離すこと。

コンタクト相互間

第 2 図

コンタクト対アース間

分類： 製品規格	標準の名称： D.L.I. コネクタ	標準のコード： 108-5124	改訂 E4	8 頁 9 頁中
-------------	-----------------------	---------------------	----------	-------------

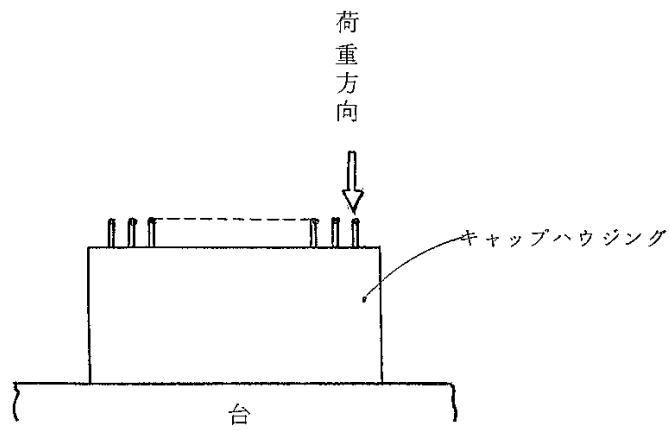

第 3 図

分類： 製品規格	標準の名称： D.L.I. コネクタ	標準のコード： 108-5124	改訂 E4	9 頁 9 頁中
-------------	-----------------------	---------------------	----------	-------------