

NUMBER  
C-1734148

3RD ANGLE PROJECTION

METRIC

THIS INFORMATION IS CONFIDENTIAL AND IS DISCLOSED TO YOU ON CONDITION THAT NO FURTHER DISCLOSURE IS MADE BY YOU TO OTHER THAN AMP PERSONNEL WITHOUT WRITTEN AUTHORIZATION FROM AMP (TAIWAN) LTD.  
DIMENSIONS IN MILLIMETERS. DO NOT SCALE PRINT.

PRINT DIST  
DW

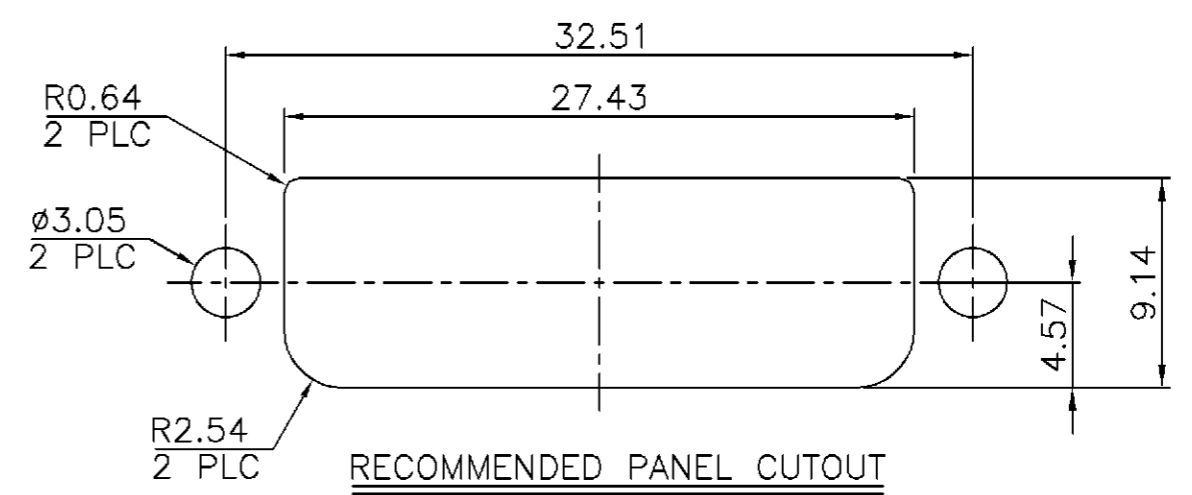
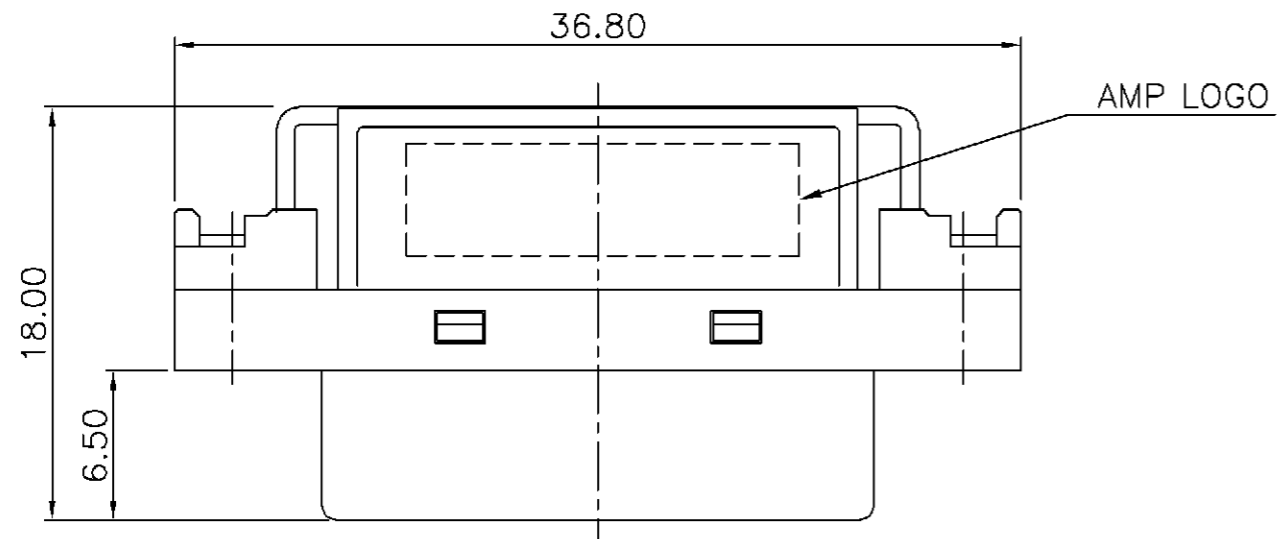

RECOMMENDED PANEL CUTOUT

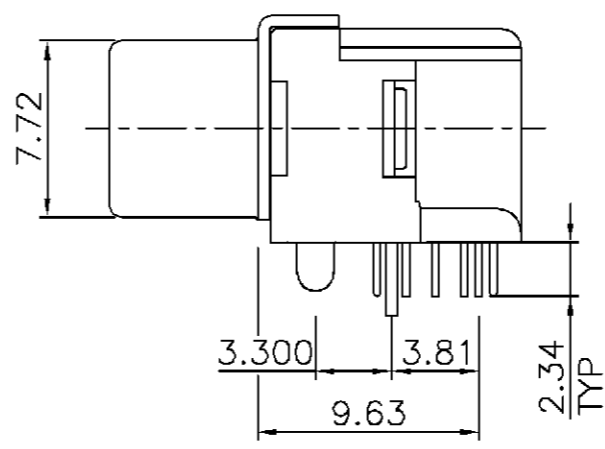
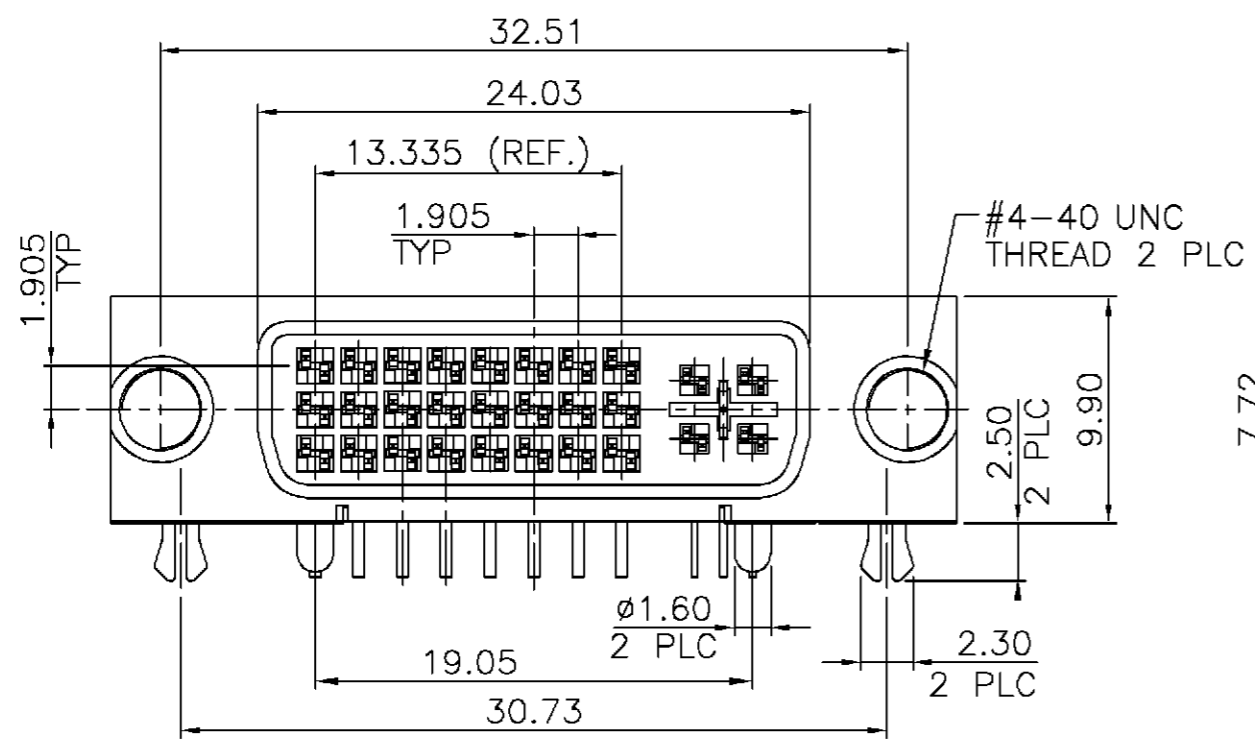

NOTES:

- MATERIAL:  
HOUSING: THERMOPLASTIC, UL 94V-0 RATED WHITE COLOR.  
CONTACT: PHOSPHOR BRONZE, THICKNESS=0.3mm.  
ANALOG CONTACT: PHOSPHOR BRONZE, THICKNESS=0.3mm.  
ANALOG GROUND: PHOSPHOR BRONZE, THICKNESS=0.3mm.  
SHELL: STEEL.  
HOOK: BRASS, THICKNESS=0.5mm.  
NUT: BRASS.
- FINISH:  
CONTACT: GOLD PLATED(SEE TABLE) ON CONTACT AREA.  
100 μ" MIN. TIN PLATED ON SOLDER TAILS  
50 μ" MIN. NICKEL UNDERPLATED OVERALL  
SHIELD: 50 μ" MIN. NICKEL UNDERPLATED OVERALL  
HOOK : BRASS. PLATING : TIN PLATED OVER  
NUT : BRASS, NICKEL PLATED.  
#4-40 UNC SCREW, SCREW HEAD LENGTH: 6.0±0.5mm.  
SCREW SEPARATELY PACKED.

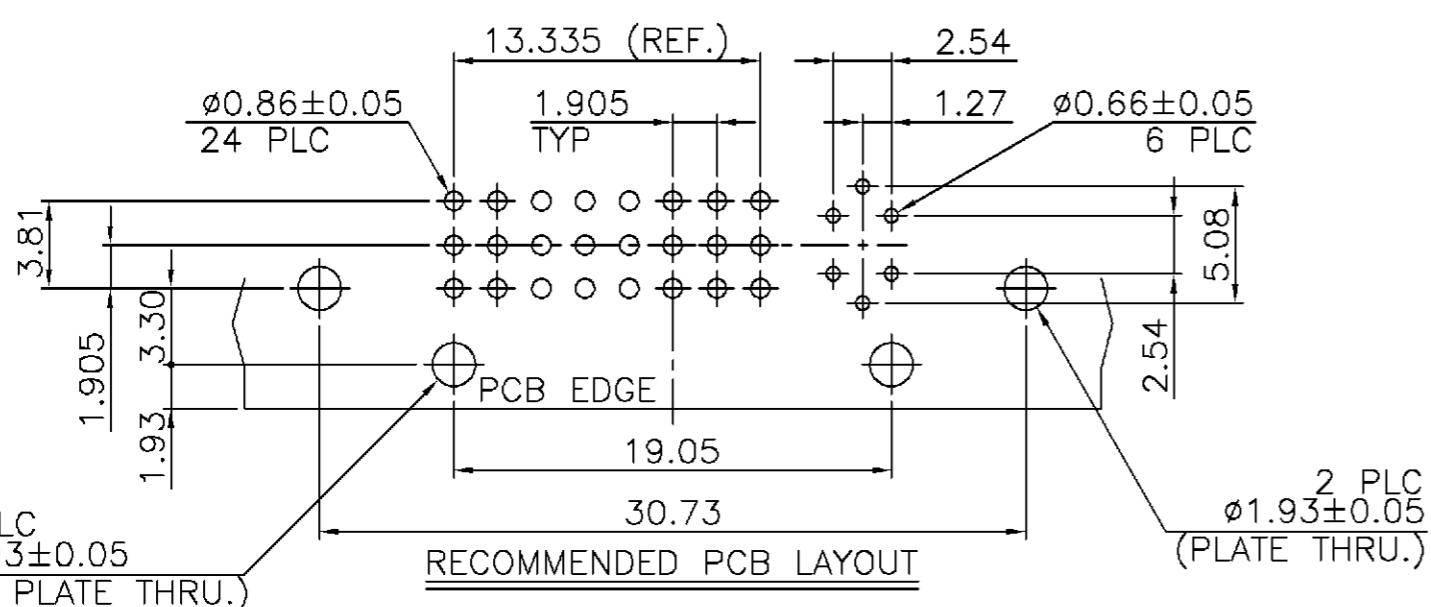

RECOMMENDED PCB LAYOUT

W/	GOLD FLASH	2-1734148-1
W/	30u"	1-1734148-3
W/	10u"	1-1734148-2
W/	GOLD FLASH	1-1734148-1
W/O	30u"	1734148-3
W/O	10u"	1734148-2
W/O	GOLD FLASH	1734148-1
SCREW	GOLD PLATED	PART NUMBER

TOLERANCES UNLESS OTHERWISE SPECIFIED: 0 PLC ± 1 PLC ± 0.35 2 PLC ± 0.25 3 PLC ± 0.15 ANGLES ± 1'	DWN O. HU 21-JUN-2004	 TYCO HOLDINGS (BERMUDA) VII LTD. TAIWAN BRANCH
MATERIAL SEE NOTE	CHK S. HOU 21-JUN-2004	
FINISH SEE NOTE	APVD T. KE 21-JUN-2004	DVI-I ANALOG & DIGITAL CONN. RCPT. RIGHT ANGLE.
	PRODUCT SPEC 108-1941	LOC DW A <sub>3</sub> C-1734148 REV O
	APPLICATION SPEC -	SCALE -- SHEET 1 OF 2
	WEIGHT	

O	FIRST RELEASED	FZ00-0136-04	OH SH	25APR 2004
LTR	REVISION RECORD	ECN	DWN CHK	DATE

THIS INFORMATION IS CONFIDENTIAL AND IS DISCLOSED TO YOU ON CONDITION THAT NO FURTHER DISCLOSURE IS MADE BY YOU TO OTHER THAN AMP PERSONNEL WITHOUT WRITTEN AUTHORIZATION FROM AMP (TAIWAN) LTD. DIMENSIONS IN MILLIMETERS. DO NOT SCALE PRINT.

PRINT DIST  
DW

METRIC

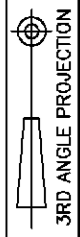

NUMBER  
C-1734148

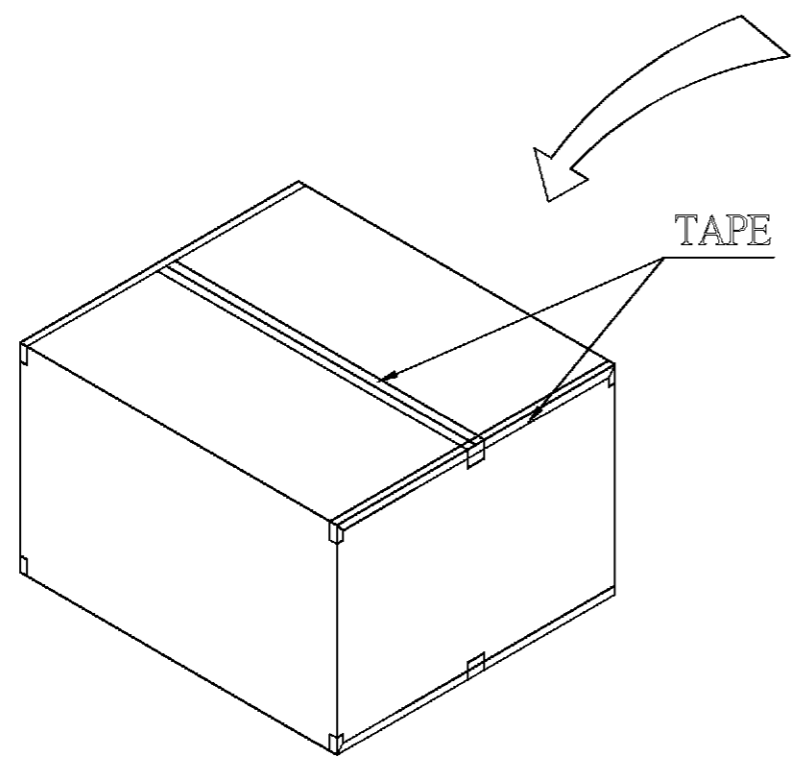

5 TRAY PER CARTON

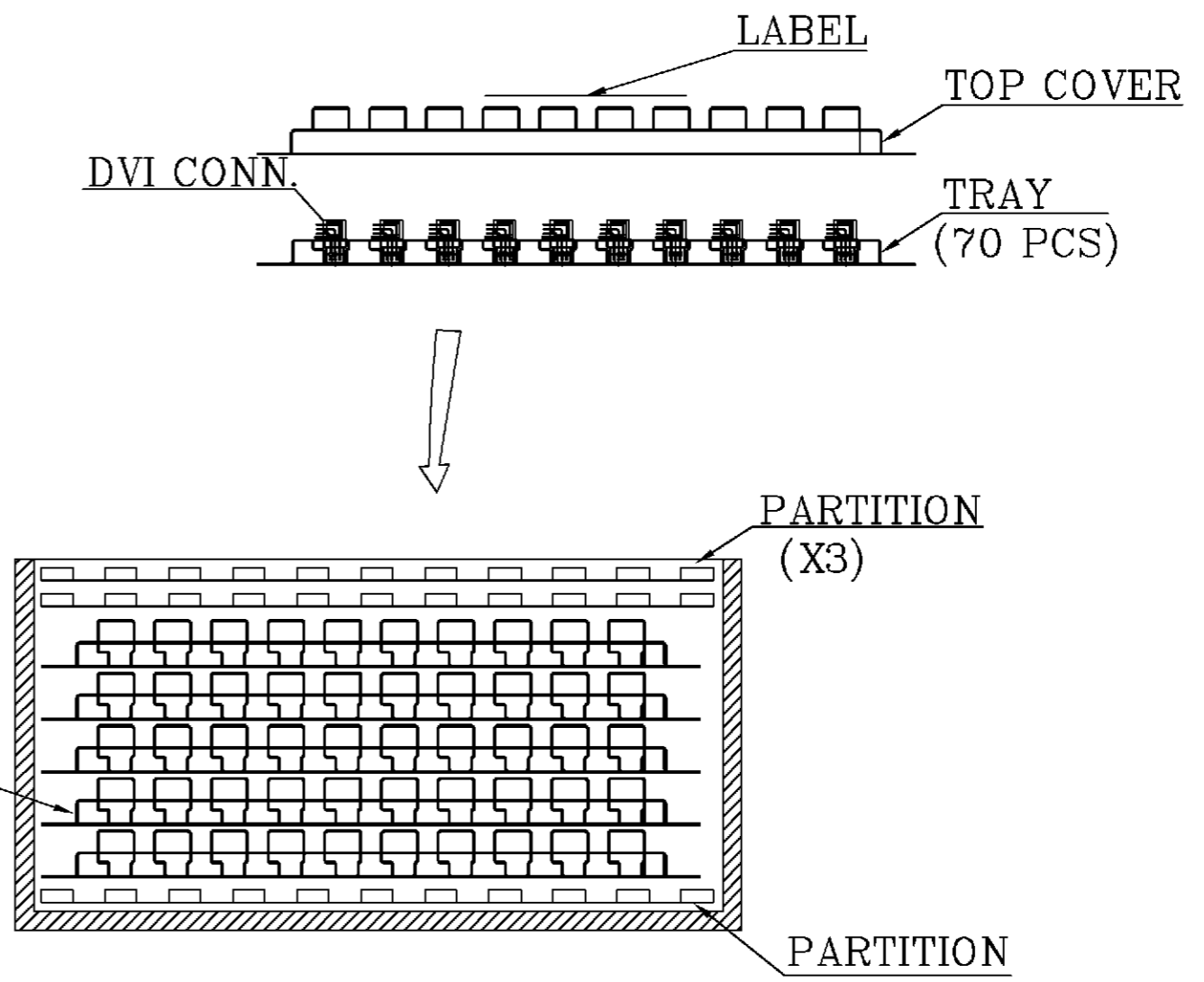

3.55	2.63	340X278X146	340X275X19.6	350
G.W./CARTON	N.W./CARTON	CARTON SIZE	TRAY SIZE	QUANTITY

SEE SHEET 1.	ECN	DWN	CHK	DATE
LTR	REVISION RECORD			

TOLERANCES UNLESS OTHERWISE SPECIFIED: 0 PLC ± 1 PLC ± 2 PLC ± 3 PLC ± ANGLES ±	DWN	O. HU	<b>tyco</b> TYCO HOLDINGS (BERMUDA) <b>Electronics</b> VII LTD. TAIWAN BRANCH			
	CHK	S. HOU				
MATERIAL  SEE NOTE	APVD	T. KE	NAME  DVI-I ANALOG & DIGITAL CONN. RCPT. RIGHT ANGLE.			
	PRODUCT SPEC	21-JUN-2004				
FINISH  SEE NOTE	APPLICATION SPEC	-	LOC	SIZE	DRAWING NO	REV
	WEIGHT	-	DW	A <sub>3</sub>	C-1734148	O
			SCALE	SHEET		
			--	2 OF 2		

CUSTOMER DRAWING

8

7

6

5

4

3

2

1

D

C

B

A