

NUMBER
C-1734351

3RD ANGLE PROJECTION

METRIC

THIS INFORMATION IS CONFIDENTIAL AND IS DISCLOSED TO YOU ON CONDITION THAT NO FURTHER DISCLOSURE IS MADE BY YOU TO OTHER THAN AMP PERSONNEL WITHOUT WRITTEN AUTHORIZATION FROM AMP (TAIWAN) LTD. DIMENSIONS IN MILLIMETERS. DO NOT SCALE PRINT.

PRINT DIST
DW

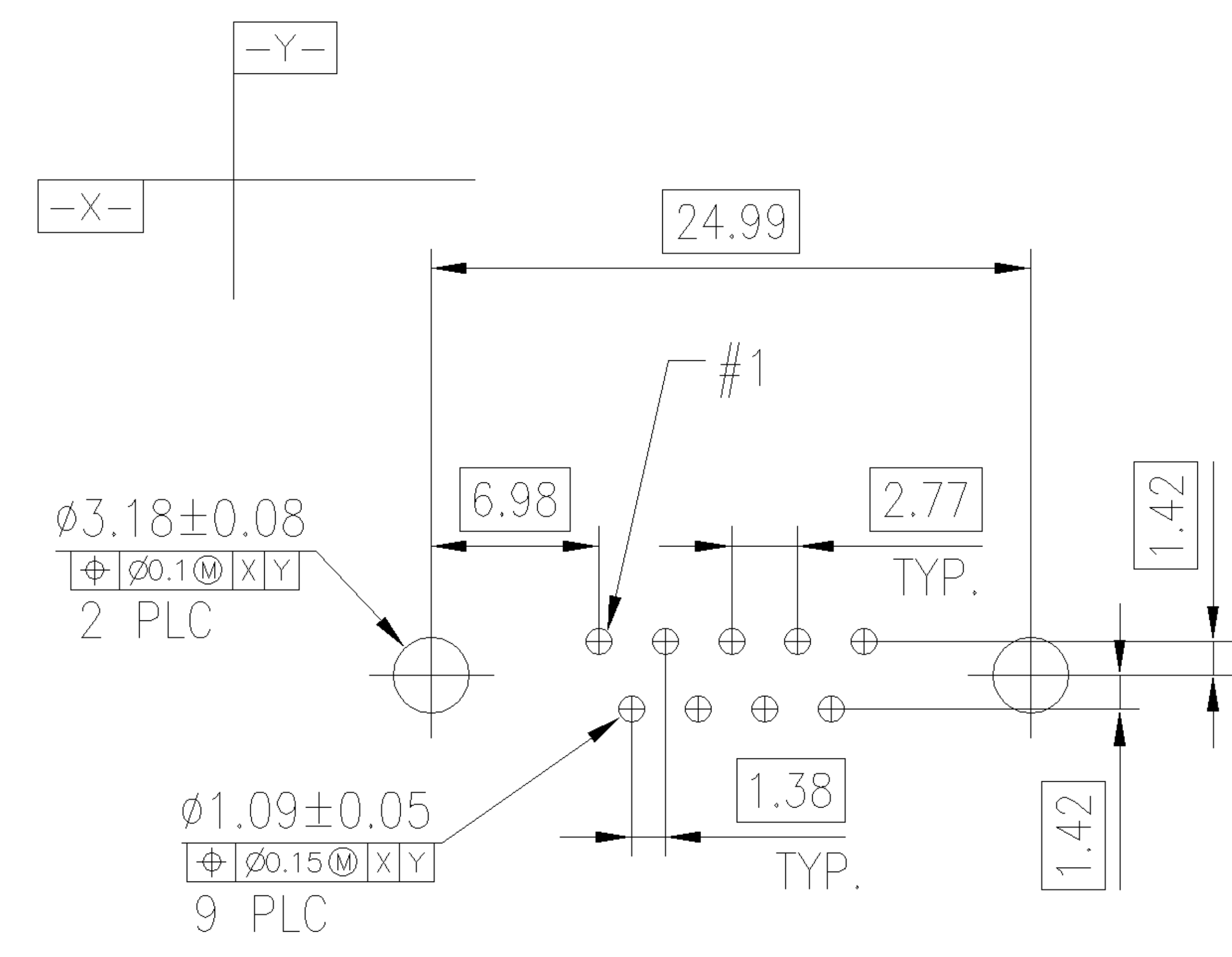
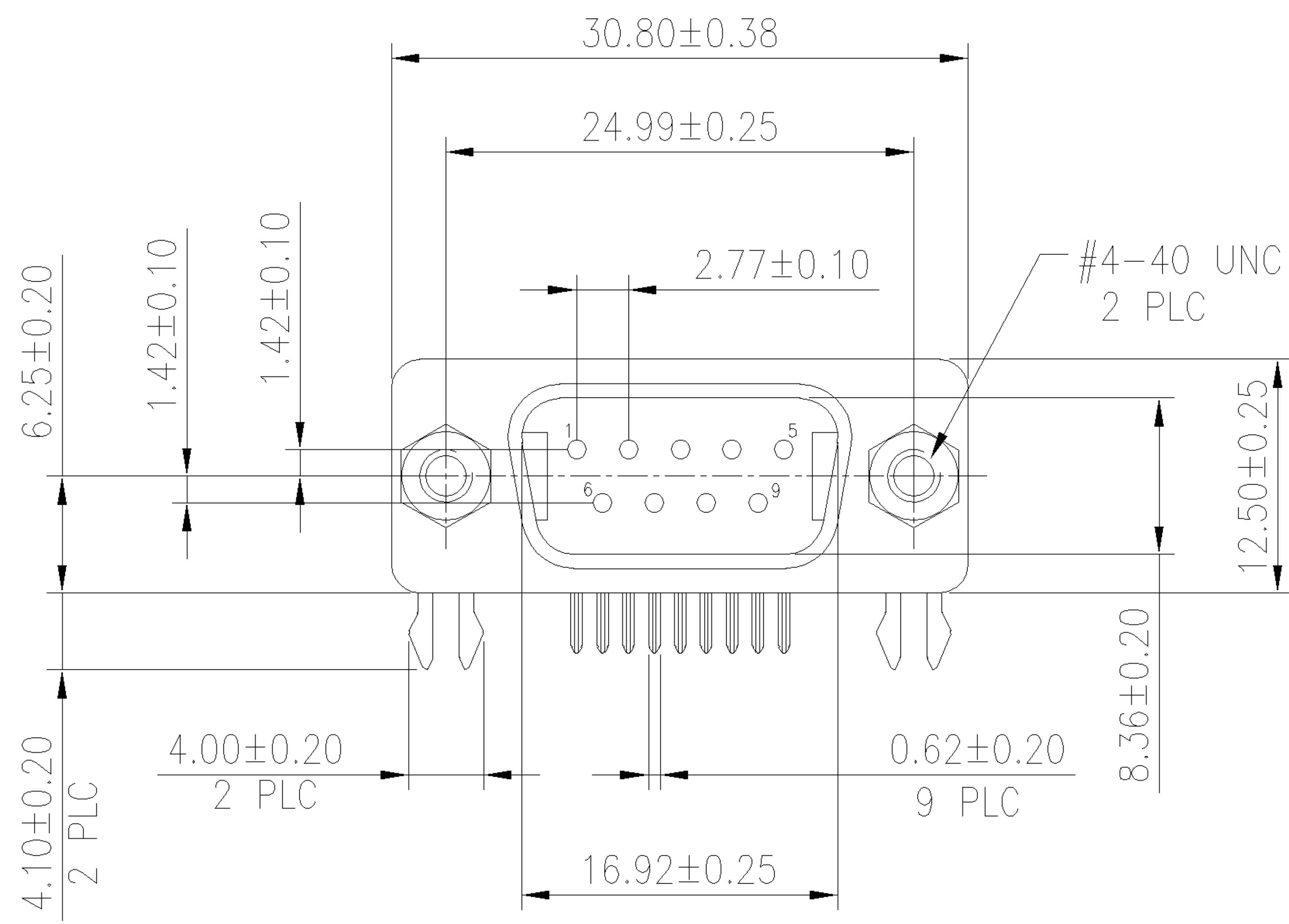

- NOTES:
- MATERIAL :
 - HOUSING: THERMOPLASTIC, UL 94V-0 RATED, BLACK
 - CONTACTS: BRASS
 - SHELL: SPCC
 - BOARDLOCKS: BRASS.
 - RIVET: COPPER ALLOY
 - SCREWLOCKS: COPPER ALLOY BRASS, THREAD LENGTH OF SCREW: 6.0 MIN.
 - FINISH:
 - CONTACT: GOLD PLATING ON CONTACT AREA. (SEE TABLE) 100u" MIN. MATTE TIN PLATING ON SOLDER TAIL AREA, 50u" MIN. NICKEL UNDERPLATING OVERALL,
 - BOARDLOCK: 100u" MIN MATTE TIN PLATING 50u" MIN NICKEL UNDERPLATING OVERALL,
 - SHELL: NICKEL PLATED
 - RIVET: NICKEL PLATING OVERALL
 - RECOMMENDED PCB THICKNESS: 1.6 mm
 - WAVE SOLDER CAPABLE TO 265°C PER TYCO SPEC. 109-202, CONDITION B.
 - THREADED INSERTS AND SCREWLOCKS MUST WITHSTAND 6 IN-LBS TORQUE AND 20 LBS PUSH OUT FROM MATING FACE SIDE.

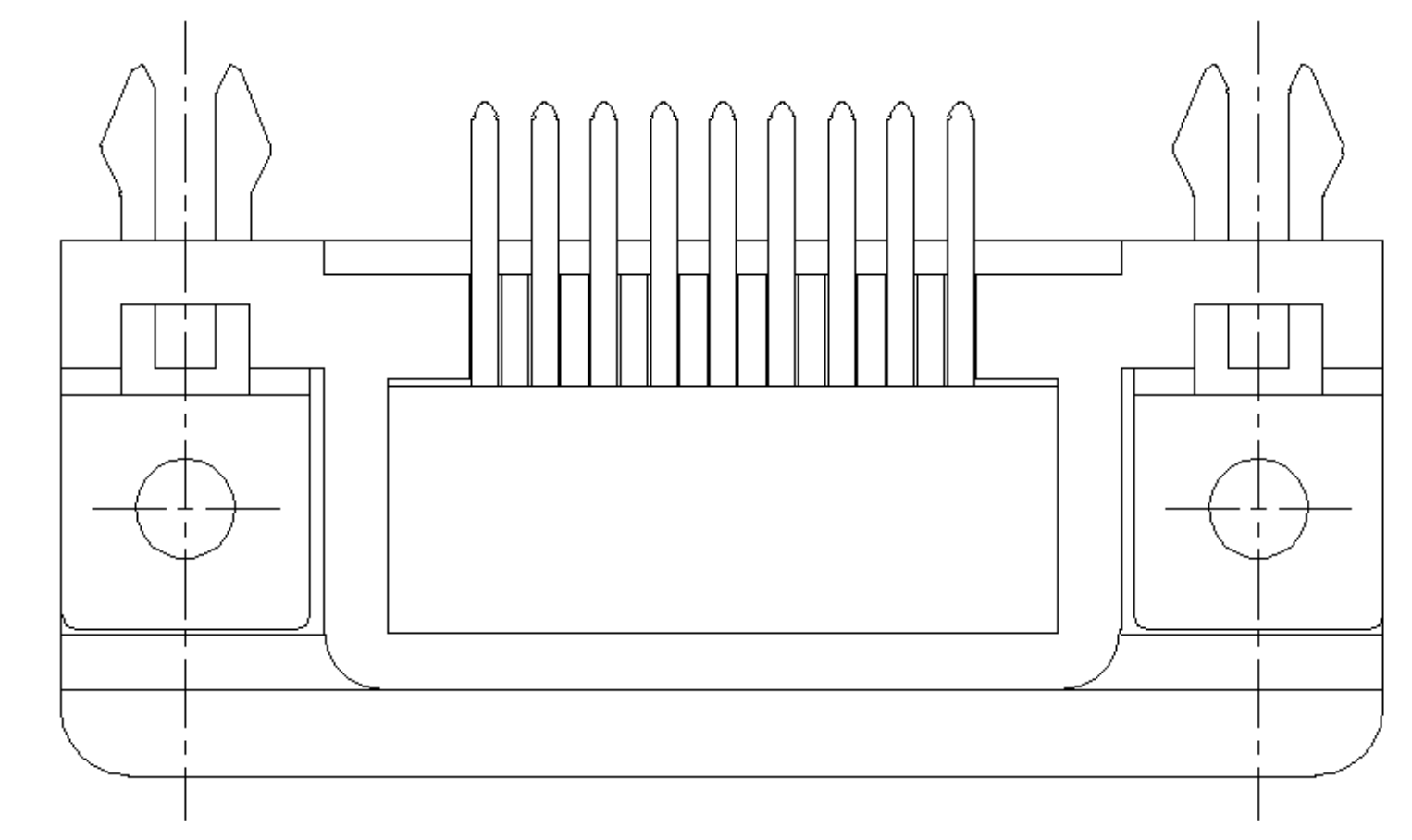
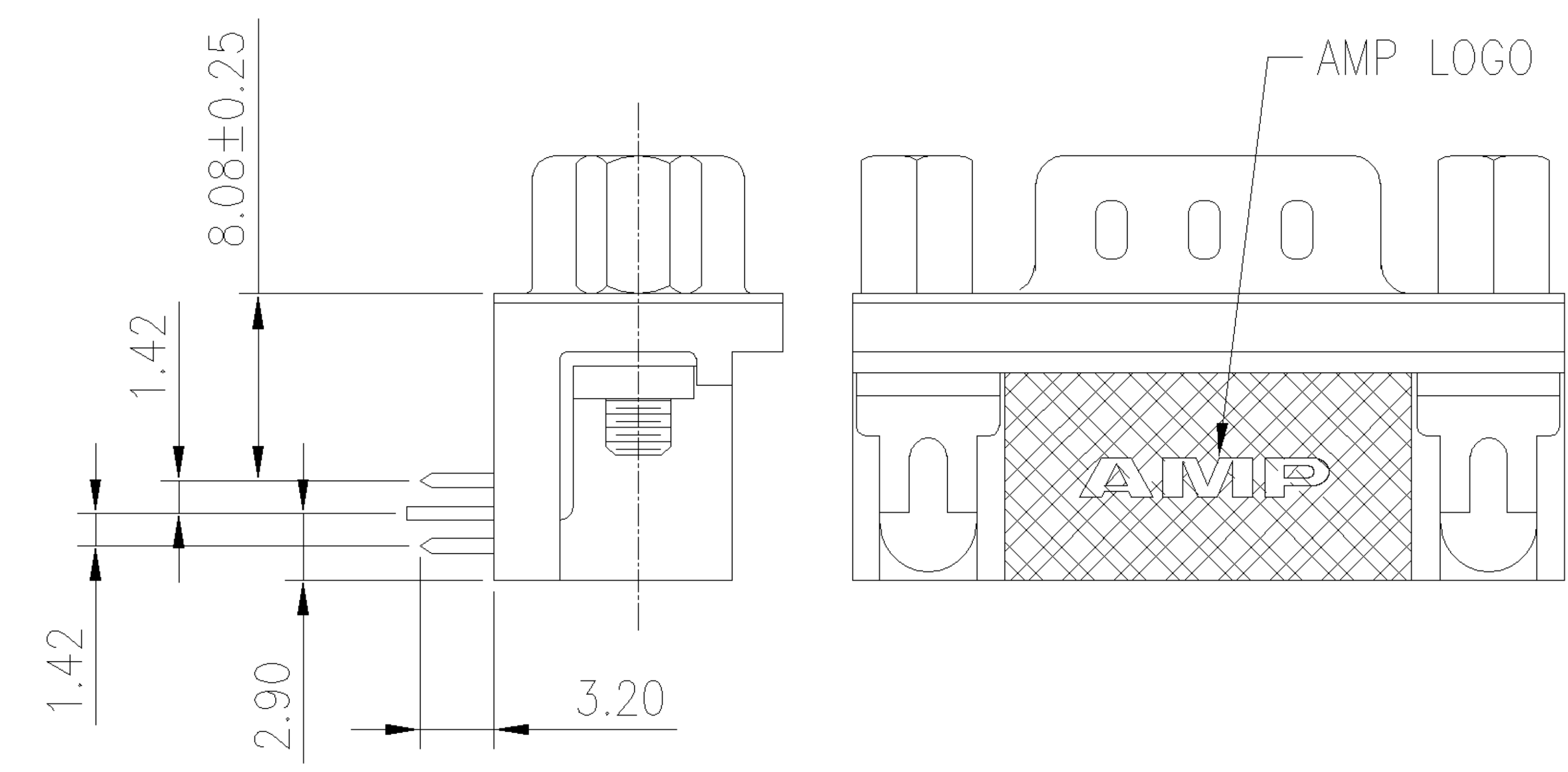
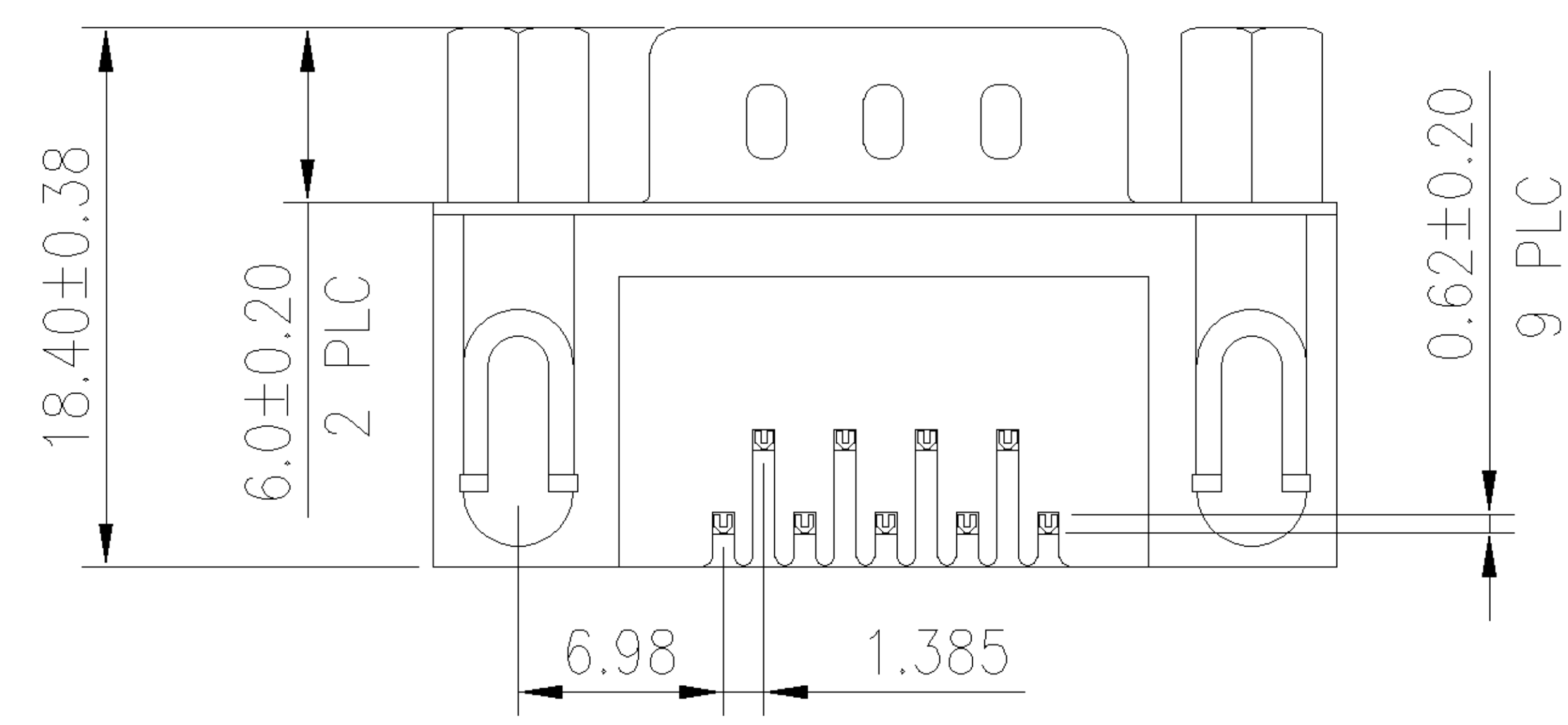

15 u"	1734351-2
G/F	1734351-1
GOLD PLATING	PART NUMBER

TOLERANCES UNLESS OTHERWISE SPECIFIED		DWN	J. LEE	tyco Electronics TYCO HOLDINGS (BERMUDA) VII LTD. TAIWAN BRANCH
0 PLC ±0.5 1 PLC ±0.25 2 PLC ±0.15 3 PLC ±0.1 ANGLES ±3°		CHK	S. HOU	
MATERIAL		APVD	W.J. KE	PLUG ASSEMBLY, 9 POSN, RIGHT ANGLE, 8.08mm SERIES, AMPLIMITE, WITH SCREWLOCKS
SEE NOTE		PRODUCT SPEC	108-57541	
FINISH		APPLICATION SPEC	501-57623	LOC DW
SEE NOTE		WEIGHT	9.0 GRAMS	SCALE
O FIRST RELEASED -- JL SH 20-SEP-2005		DRAWING NO		REV
LTR REVISION RECORD ECN DWN CHK DATE		C-1734351		O
		SHEET		1 OF 2

CUSTOMER DRAWING

NUMBER
C-1734351

3RD ANGLE PROJECTION

METRIC

THIS INFORMATION IS CONFIDENTIAL AND IS DISCLOSED TO YOU ON CONDITION THAT NO FURTHER DISCLOSURE IS MADE BY YOU TO OTHER THAN AMP PERSONNEL WITHOUT WRITTEN AUTHORIZATION FROM AMP (TAIWAN) LTD. DIMENSIONS IN MILLIMETERS. DO NOT SCALE PRINT.

PRINT DIST
DW

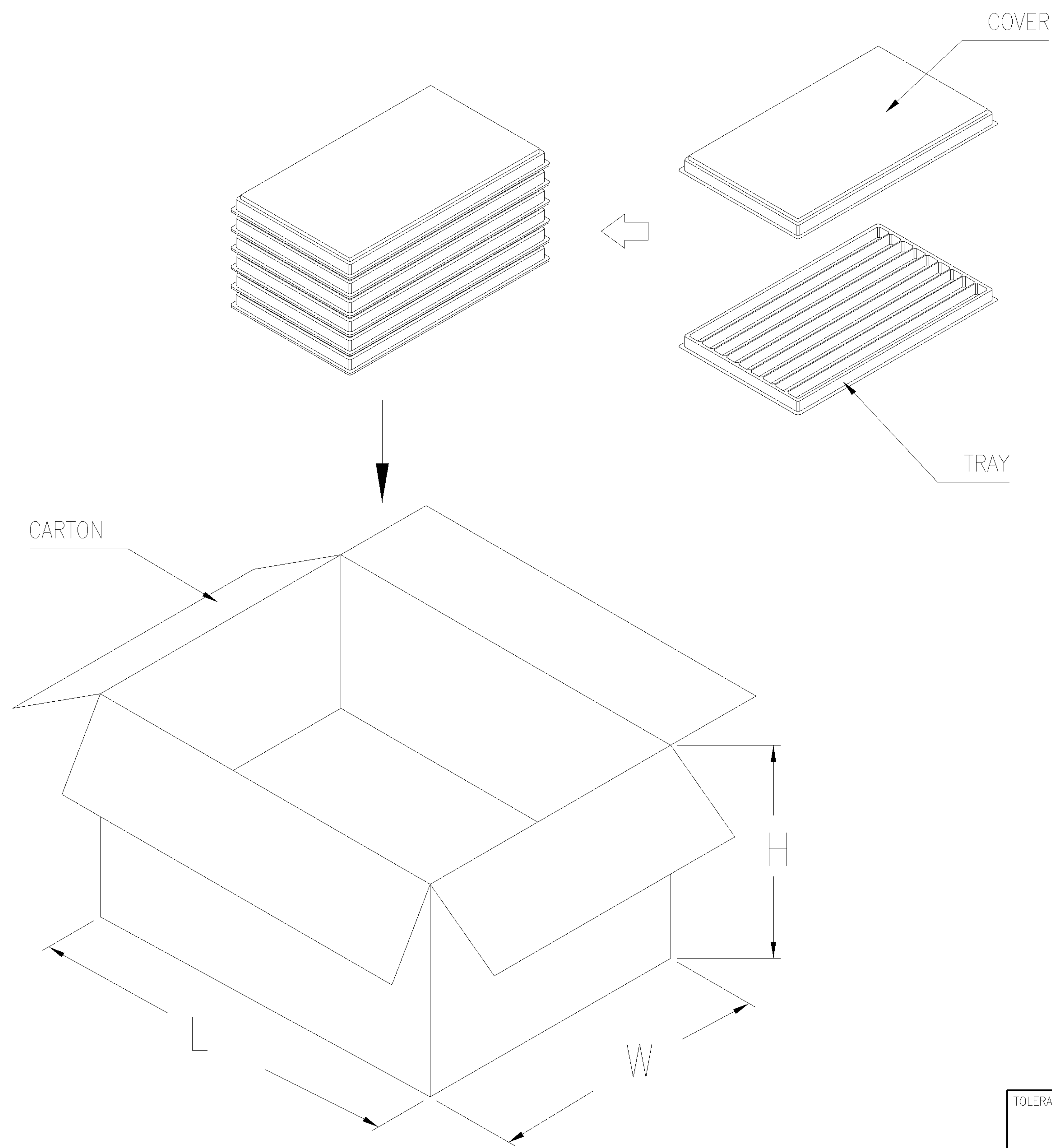

NOTES:

1. MATERIAL:
 - 1.1 TRAY: PVC
 - 1.2 SHIPPING CARTON: CORRUGATED FIBERBOARD
2. DIMENSION:
 - 2.1 TRAY: L=340, W=228, H=17.4
 - 2.2 SHIPPING CARTON: L=440, W=321, H=150
3. QUANTITY:
 - 3.1 PRIMARY PACKING: 90 PCS/TRAY
 - 3.2 SECONDARY PACKING: 11 TRAY/CARTON(990PCS)
4. WEIGHT:
 - 4.1 NET WEIGHT: 8.91 Kg (W/SCREWLOCK)
 - 4.2 GROSS WEIGHT: 9.91 Kg (W/SCREWLOCK)

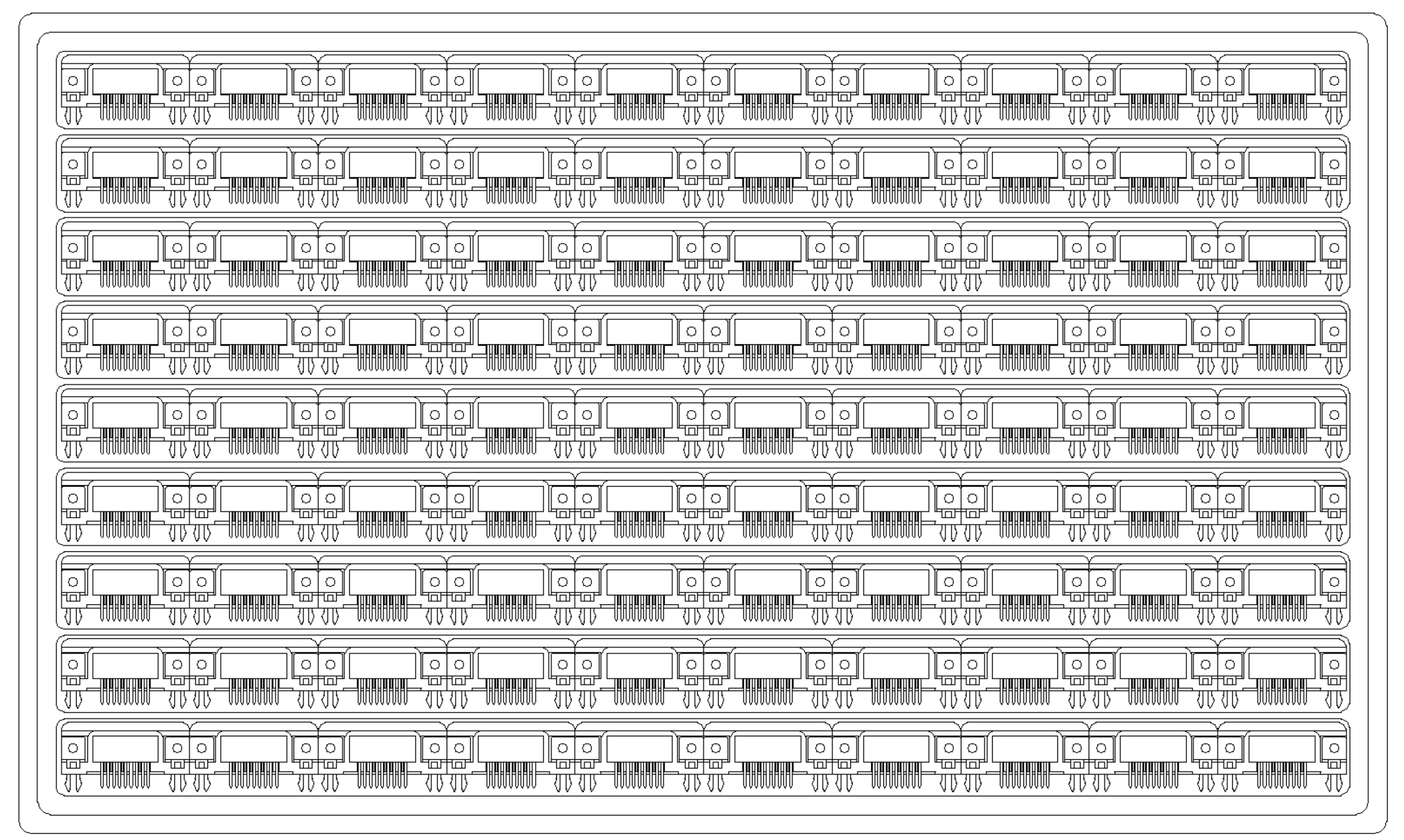

SEE SHEET 1	ECN	DWN	CHK	DATE
LTR	REVISION RECORD			

TOLERANCES UNLESS OTHERWISE SPECIFIED: 0 PLC ± 1 PLC ± 2 PLC ± 3 PLC ± ANGLES ±		DWN J. LEE 20-SEP-2005	tyco TYCO HOLDINGS (BERMUDA) Electronics VII LTD. TAIWAN BRANCH NAME PLUG ASSEMBLY, 9 POSN, RIGHT ANGLE, 8.08mm SERIES, AMPLIMITE, WITH SCREWLOCKS	
MATERIAL SEE NOTE	CHK S. HOU 20-SEP-2005	APVD W.J. KE 20-SEP-2005		
FINISH SEE NOTE	PRODUCT SPEC --	QUALIFICATION TEST REPORT --	LOC DW	SIZE A ₃
	WEIGHT		DRAWING NO C-1734351	REV 0
			SCALE --	SHEET 2 OF 2