

1. Scope :

1.1 Contents

This specification covers the requirements for product performance, test methods and quality assurance provisions of .070 SERIES MULTI LOCK I/O CONNECTOR (MLC) FOR P. C. B. Applicable product descriptions and part numbers are as shown in Appendix 1.

2. Applicable Documents :

The following documents form a part of this specification to the extent specified herein. In the event of conflict between the requirements of this specification and the product drawing, the product drawing shall take precedence. In the event of conflict between the requirements of this specification and the referenced documents, this specification shall take precedence.

2.1 TE Specifications :

- A. 109-5000 Test Specification, General Requirements for Test Methods
- B. 114-5091 Application Specification .070 Series Receptacle Contact Crimping Specification.
- C. 501-5052 Test Report :

2.2 Commercial Standards and Specifications :

JIS C 3406 Low Voltage Cables for Automobiles

1. 適用範囲

1.1 内容

本規格は、プリント基板用 .070 マルチロック I/O コネクタ (MLC) の製品性能、試験方法、品質保証の必要条件を規定している。
適用製品名と型番は付表 1 の通りである。

2. 参考規格類

以下規格類は本規格中で規定する範囲内に於いて、本規格の一部を構成する。万一本規格と製品図面
の間に不一致が生じた時は、製品図面を優先して適用すること。万一本規格と参考規格類の間に不
致が生じた時は、本規格を優先して適用すること。

2.1 TE 規格

- A. 109-5000 : 試験法の一般条件
- B. 114-5091 : 取付適用規格 .070 シリーズリセプタクルコンタクト圧着規格
- C. 501-5052 : 試験報告書

2.2 民間団体規格

JIS C 3406 自動車用低圧電線

3. Requirements:

3.1 Design and Construction :

Product shall be of the design, construction and physical dimensions specified in the applicable product drawing.

3.2 Materials :

A. Contact :

Tab contact :Pre-tinned brass, or Plain brass with selective gold plating over nickel underplate

Receptacle contact :Pre-tinned phosphor bronze and brass strip, or plain phosphor bronze and brass strip with selective gold plating over nickel underplate

B. Housing :

Polybithylene : terephthalateresin (PBT)

C. Others :

3.3 Ratings :

Temperature Rating : -30°C to 105°C

3.4 Performance and Test Descriptions :

The product shall be designed to meet the electrical, mechanical and environmental performance requirements specified in Fig. 2. All tests shall be performed in the room temperature, unless otherwise specified.

3. 一般必要条件

3.1 設計と構造

製品は該当製品図面に規定された設計、構造、物理的寸法をもって製造されていること。

3.2 材 料

A. コンタクト

コンタクトはすずめっき済又は金めっき付黄銅条及び磷青銅条

B.ハウジング

ハウジングは PBT 樹脂

C. その他

3.3 定 格

使用温度範囲 $-30^{\circ}\text{C}\sim 105^{\circ}\text{C}$

3.4 性能必要条件と試験方法

製品は Fig. 2 に規定された電氣的、機械的及び耐環境的性能条件に合致するよう設計されていること。試験は特別に規定されない限り室温下で行われること。

3.5 Test Requirements and Procedures Summary 3.5 性能必要条件と試験方法の要約

* 1; In the event of conflict between the requirement of this specification and TE Spec., this specification shall take precedence.

* 1; 本内容と TE Spec.に不一致が生じた時は、本内容を優先する。

Para. 項目	Test Items 試験項目	Requirements 規格値		Procedures 試験方法 *1
3.5.1	Confirmation of Product	Product shall be conforming to the requirements of applicable product drawing and Application Specification .		Visually, dimensionally and functionally inspected per applicable quality inspection plan.
3.5.1	製品の確認検査	製品図面と TE 取付適用規格の必要条件に合致していること。		該当する検査基準書に基づいて目視、寸法、及び機能検査を行うこと。
Electical Requirements 電氣的性能				
3.5.2	Termination Resistance (Specified Current)	Test Current (A)	Resistance mV/A (max.)	Measure initial millivolt drop of contact test circuit in mated connectors, Fig. 3 TE Spec. 109-5311-2
		1	Initial : 3 Final : 10	
3.5.2	総合抵抗 (規定電流)	試験電流 (A)	抵抗値 mV/A 以下	嵌合したコネクタの試験用回路の初期電圧降下を測定、Fig. 3 参照。 TE 規格 109-5311-2
		1	初期 : 3 終期 : 10	
3.5.3	Termination Resistance (Low Level)	3 m Ω Max. (Initial) 10 mΩ Max. (Final)		Subject mated contacts assembled in housing to closed circuit current of 10 mA Max. at open circuit voltage of 20 mV Max. Fig. 3 TE Spec. 109-5311-1
3.5.3	総合抵抗 (ローレベル)	3 mΩ 以下 (初期) 10 mΩ 以下 (終期)		ハウジングに組み込まれ嵌合したコンタクトを開路電圧 20 mV 以下、閉路電流 10 mA 以下の条件で測定する。 Fig. 3 参照。 TE 規格 109-5311-1

Fig. 2 (続く) (To be continued)

Para. 項目	Test Items 試験項目	Requirements 規格値	Procedures 試験方法
3.5.4	Dielectric Strength	No creeping discharge nor flashover shall occur.	1.8 kVAC for 1 min Test between adjacent circuits of mated connectors. TE Spec. 109-5301
3.5.4	耐電圧	沿面放電、フラッシュオーバー等がないこと。	1.8 kVAC 1 分間印加 コネクタ嵌合あり 隣接コンタクト間で測定 TE 規格 109-5301
3.5.5	Insulation Resistance	100 MΩ Min. (Initial) 100 MΩ Min. (Final)	Impressed voltage 500 V DC. Test between adjacent circuits of mated connectors. TE Sepc. 109-5302 Fig. 5
3.5.5	絶縁抵抗	100 MΩ 以上 (初期) 100 MΩ 以下 (終期)	500 VDC 印加。 コネクタ嵌合あり 隣接コンタクト間で測定 TE 規格 109-5302 Fig. 5
3.5.6	Current Leakage	3 mA Max.	12 V DC impressed 60°C Humidity'90~95% 1h TE Spec. 109-5312 Fig. 4
3.5.6	リーク電流	3 mA 以下	12 VDC 印加 60°C 湿度 90~95% 1 時間 TE 規格 109-5312 Fig. 4
3.5.7	Temperature Rising	60°C Max. under loaded specified current.	Measure temperature rising by energized current. Fig. 7 TE Spec. 109-5310 Method
3.5.7	温度上昇	規定電流を通电して、温度上昇は 60°C 以下。	通电による温度上昇を測定すること。 Fig. 7 参照。 TE 規格 109-5310
3.5.8	Current Cycling	10 mV / A Max. (Final) 10 mΩ Max. (Final)	Applied current ; Fig. 7 45 min "ON" 15 min "OFF" 200 cycles
3.5.8	電流サイクル	10 mV / A 以下 (終期) 10 mΩ 以下 (終期)	電流条件 : Fig. 7 参照 45 分間 "ON", 15 分間 "OFF" 200 サイクル

Fig. 2 (続く) (To be continued)

Para. 項目	Test Items 試験項目	Requirements 規格値	Procedures 試験方法
Physical Requirements 機械的性能			
3.5.9	Vibration (High Frequency)	No electrical discontinuity greater than 1 μ sec. shall occur. 10 m Ω Max. (Final) 10 mV / A Max. (Final)	Vibration Frequency : 20~200-20 Hz / 1 min Accelerated Velocity : 44 m / s ² (4.5 G) Vibration Direction : X, Y, Z Duration : 8 h each TE Spec. 109-5202 Fig. 6
3.5.9	振動 (高周波)	振動中 1 μ sec をこえる不連続導通を生じないこと。 10 m Ω 以下 (終期) 10 mV / A 以下 (終期)	振動周波数 : 20~200 Hz / 1 分 加速度 : 44 m / s ² (4.5 G) 振動方法 : X, Y, Z 振動時間 : 各 8 時間 TE 規格 109-5202 Fig. 6
3.5.10	Contact Mating Force	2.9~7.8 N	Operation Speed : 100 mm / min Measure the force required to mate connectors. TE Spec. 109-5206
3.5.10	コンタクト挿入力	2.9~7.8 N	操作速度 100 mm / 分 挿入に要する力を測定 TE 規格 109-5206
3.5.11	Contact Unmating Force	2~7.8 N	Operation Speed : 100 mm / min Measure the force required to mate connectors. TE Spec. 109-5206
3.5.11	コンタクト引抜力	2~7.8 N	操作速度 100 mm / 分 挿入に要する力を測定 TE 規格 109-5206

Fig. 2 (続く) (To be continued)

Para. 項目	Test Items 試験項目	Requirements 規格値	Procedures 試験方法																						
3.5.12	Connector Mating Force	<table border="0"> <tr> <td>Number of Position (N) max.</td> <td>Force</td> </tr> <tr> <td>3</td> <td>39</td> </tr> <tr> <td>4,6</td> <td>64</td> </tr> <tr> <td>8</td> <td>68</td> </tr> <tr> <td>10</td> <td>78</td> </tr> <tr> <td>12</td> <td>93</td> </tr> <tr> <td>14</td> <td>103</td> </tr> <tr> <td>18</td> <td>128</td> </tr> <tr> <td>20</td> <td>142</td> </tr> <tr> <td>24</td> <td>See 10pos & 14pos</td> </tr> <tr> <td>30,42</td> <td>See 12pos & 18pos</td> </tr> </table>	Number of Position (N) max.	Force	3	39	4,6	64	8	68	10	78	12	93	14	103	18	128	20	142	24	See 10pos & 14pos	30,42	See 12pos & 18pos	Operation Speed : 100 mm / min. Measure the force required to mate connectors. TE Spec. 109-5206
Number of Position (N) max.	Force																								
3	39																								
4,6	64																								
8	68																								
10	78																								
12	93																								
14	103																								
18	128																								
20	142																								
24	See 10pos & 14pos																								
30,42	See 12pos & 18pos																								
3.5.12	コネクタ挿入力	<table border="0"> <tr> <td>極数</td> <td>挿入力 (N) 以下</td> </tr> <tr> <td>3</td> <td>39</td> </tr> <tr> <td>4,6</td> <td>64</td> </tr> <tr> <td>8</td> <td>68</td> </tr> <tr> <td>10</td> <td>78</td> </tr> <tr> <td>12</td> <td>93</td> </tr> <tr> <td>14</td> <td>103</td> </tr> <tr> <td>18</td> <td>128</td> </tr> <tr> <td>20</td> <td>142</td> </tr> <tr> <td>24</td> <td>10 極及び 14 極参照</td> </tr> <tr> <td>30,42</td> <td>12 極及び 18 極参照</td> </tr> </table>	極数	挿入力 (N) 以下	3	39	4,6	64	8	68	10	78	12	93	14	103	18	128	20	142	24	10 極及び 14 極参照	30,42	12 極及び 18 極参照	操作速度 100 mm / 分 挿入に要する力を測定 TE 規格 109-5206
極数	挿入力 (N) 以下																								
3	39																								
4,6	64																								
8	68																								
10	78																								
12	93																								
14	103																								
18	128																								
20	142																								
24	10 極及び 14 極参照																								
30,42	12 極及び 18 極参照																								
3.5.13	Connector Unmating Force	<table border="0"> <tr> <td>Number of Position (N) max.</td> <td>Force</td> </tr> <tr> <td>3</td> <td>2.9~39N</td> </tr> <tr> <td>4,6</td> <td>5.9~49N</td> </tr> <tr> <td>8</td> <td>7.8~59N</td> </tr> <tr> <td>10</td> <td>9.8~69N</td> </tr> <tr> <td>12</td> <td>11.8~78N</td> </tr> <tr> <td>14</td> <td>13.7~88N</td> </tr> <tr> <td>18</td> <td>17.6~118N</td> </tr> <tr> <td>20</td> <td>20~128N</td> </tr> <tr> <td>24</td> <td>See 10pos & 14pos</td> </tr> <tr> <td>30,42</td> <td>See 12pos & 18pos</td> </tr> </table>	Number of Position (N) max.	Force	3	2.9~39N	4,6	5.9~49N	8	7.8~59N	10	9.8~69N	12	11.8~78N	14	13.7~88N	18	17.6~118N	20	20~128N	24	See 10pos & 14pos	30,42	See 12pos & 18pos	Operation Speed : 100 mm / min. Measure the force required to unmate connectors. TE Spec. 109-5206
Number of Position (N) max.	Force																								
3	2.9~39N																								
4,6	5.9~49N																								
8	7.8~59N																								
10	9.8~69N																								
12	11.8~78N																								
14	13.7~88N																								
18	17.6~118N																								
20	20~128N																								
24	See 10pos & 14pos																								
30,42	See 12pos & 18pos																								

Fig. 2 (続く) (To be continued)

Para. 項目	Test Items 試験項目	Requirements 規格値	Procedures 試験方法																								
3.5.13	コネクタ引抜力	<table border="0"> <tr> <td>極数</td> <td>引抜力</td> </tr> <tr> <td></td> <td>(N) 以下</td> </tr> <tr> <td>3</td> <td>2.9~39N</td> </tr> <tr> <td>4,6</td> <td>5.9~49N</td> </tr> <tr> <td>8</td> <td>7.8~59N</td> </tr> <tr> <td>10</td> <td>9.8~69N</td> </tr> <tr> <td>12</td> <td>11.8~78N</td> </tr> <tr> <td>14</td> <td>13.7~88N</td> </tr> <tr> <td>18</td> <td>17.6~118N</td> </tr> <tr> <td>20</td> <td>20~128N</td> </tr> <tr> <td>24</td> <td>10 極及び 14 極参照</td> </tr> <tr> <td>30,42</td> <td>12 極及び 18 極参照</td> </tr> </table>	極数	引抜力		(N) 以下	3	2.9~39N	4,6	5.9~49N	8	7.8~59N	10	9.8~69N	12	11.8~78N	14	13.7~88N	18	17.6~118N	20	20~128N	24	10 極及び 14 極参照	30,42	12 極及び 18 極参照	<p>操作速度 100 mm / 分 引抜に要する力を測定 TE 規格 109-5206</p>
極数	引抜力																										
	(N) 以下																										
3	2.9~39N																										
4,6	5.9~49N																										
8	7.8~59N																										
10	9.8~69N																										
12	11.8~78N																										
14	13.7~88N																										
18	17.6~118N																										
20	20~128N																										
24	10 極及び 14 極参照																										
30,42	12 極及び 18 極参照																										
3.5.14	Connector Locking Strength	98 N Min.	<p>Measure connector locking strength. Operation Speed : 100 mm / min TE Spec. 109-5210</p>																								
3.5.14	コネクタ・ロック強度	98 N 以上	<p>コネクタのロック強度を測定 操作速度 100 mm / 分 TE 規格 109-5210</p>																								
3.5.15	Contact Insertion Force	14.7 N Max. per contact.	<p>Measure the force required to insert contact into housing. TE Spec. 109-5211</p>																								
3.5.15	コンタクト装着力	14.7 N 以下 1 コンタクト当たり	<p>コンタクトをハウジングに装着するに要する力を測定すること。 TE 規格 109-5211</p>																								
3.5.16	Contact Retention Force	78.5 N Min.	<p>Apply an axial pull-off load to crimped wire. Operation Speed : 100 mm / min TE Spec. 109-5212</p>																								
3.5.16	コンタクト保持力	78.5 N 以上	<p>コンタクト引抜力を軸方向に加えること。 操作速度 : 100 mm / 分 TE 規格 109-5212</p>																								
3.5.17	Contact Retention Force (secondary lock)	98 N Min.	<p>Measure contact retention force with secondary lock set in effect. Operation Speed : 100 mm / min</p>																								
3.5.17	コンタクト保持力 (二重係止)	98 N 以上	<p>二重係止時のコンタクト保持力を測定 操作速度 : 100 mm / 分</p>																								

Fig. 2 (続く) (To be continued)

Para. 項目	Test Items 試験項目	Requirements 規格値	Procedures 試験方法																					
3.5.18	Crimp Tensile Strength	<table border="0"> <tr> <td>Wire Size</td> <td></td> <td>Crimp Tensile</td> </tr> <tr> <td>mm² (AWG)</td> <td></td> <td>N (min.)</td> </tr> <tr> <td>0.2 #24</td> <td></td> <td>69</td> </tr> <tr> <td>0.3 #22</td> <td></td> <td>78</td> </tr> <tr> <td>0.5 #20</td> <td></td> <td>88</td> </tr> <tr> <td>0.85 #18</td> <td></td> <td>128</td> </tr> <tr> <td>1.25 #16</td> <td></td> <td>177</td> </tr> </table>	Wire Size		Crimp Tensile	mm ² (AWG)		N (min.)	0.2 #24		69	0.3 #22		78	0.5 #20		88	0.85 #18		128	1.25 #16		177	<p>Apply an axial pull-off load to crimped wire of contact secured on the tester, Operation Speed : 100 mm / min TE Spec. 109-5205</p>
Wire Size		Crimp Tensile																						
mm ² (AWG)		N (min.)																						
0.2 #24		69																						
0.3 #22		78																						
0.5 #20		88																						
0.85 #18		128																						
1.25 #16		177																						
3.5.18	圧着部引張強度	<p>電線サイズ 引張強度 「上記英文の数字を参照」</p>	<p>圧着したコンタクトを試験機に固定し、軸方向引張力を電線に加える。 操作速度 : 100 mm / 分 TE 規格 109-5205</p>																					
3.5.19	Durability (Repeated Mate / Unmating)	<p>10 mΩ Max. (Final) 10 mV / A Max. (Final)</p>	<p>Operation Speed : 100 mm / min No. of Cycles : 30 cycles TE Spec. 109-5213</p>																					
3.5.19	耐久性 (繰り返し挿抜)	<p>10 mΩ 以下 (終期) 10 mV / A 以下 (終期)</p>	<p>操作速度 100 mm / 分 挿抜回数 30 回 TE 規格 109-5213</p>																					
3.5.20	Resistance to "Kojiri"	<p>10 mΩ Max. (Final) 10 mV / A Max. (Final)</p>	<p>Repeated mating / unmating by hand, 30 cycles TE Spec. 109-5215</p>																					
3.5.20	こじり耐久性	<p>10 mΩ 以下 (試験後) 10 mV / A 以下 (試験後)</p>	<p>手指で 30 回の挿抜を行う。 TE 規格 109-5215</p>																					
3.5.21	Solderability	<p>Wet Solder Coverage : 95 % Min. (Plating area only)</p>	<table border="0"> <tr> <td>Solder Temperature : 230±5 °C</td> </tr> <tr> <td>Immersion Duration : 3±0.5 s</td> </tr> <tr> <td>Flux : Alpha 100</td> </tr> <tr> <td>TE Spec. 109-5203</td> </tr> <tr> <td>Matte Tin plating only</td> </tr> <tr> <td>Solder Temperature : 235±5 °C</td> </tr> <tr> <td>Immersion Duration : 3±0.5 s</td> </tr> <tr> <td>Flux : Alpha 100</td> </tr> <tr> <td>TE Spec. 109-5203</td> </tr> </table>	Solder Temperature : 230±5 °C	Immersion Duration : 3±0.5 s	Flux : Alpha 100	TE Spec. 109-5203	Matte Tin plating only	Solder Temperature : 235±5 °C	Immersion Duration : 3±0.5 s	Flux : Alpha 100	TE Spec. 109-5203												
Solder Temperature : 230±5 °C																								
Immersion Duration : 3±0.5 s																								
Flux : Alpha 100																								
TE Spec. 109-5203																								
Matte Tin plating only																								
Solder Temperature : 235±5 °C																								
Immersion Duration : 3±0.5 s																								
Flux : Alpha 100																								
TE Spec. 109-5203																								
3.5.21	はんだ付け性	<p>95 % 以上ぬれていること。 (破断面を除く)</p>	<table border="0"> <tr> <td>はんだ温度 230±5 °C</td> </tr> <tr> <td>はんだ浸漬時間 3±0.5 秒</td> </tr> <tr> <td>使用フラックス : アルファ 100</td> </tr> <tr> <td>TE 規格 109-5203</td> </tr> <tr> <td>マット錫めっき品のみ</td> </tr> <tr> <td>はんだ温度 235±5 °C</td> </tr> <tr> <td>はんだ浸漬時間 3±0.5 秒</td> </tr> <tr> <td>使用フラックス : アルファ 100</td> </tr> <tr> <td>TE 規格 109-5203</td> </tr> </table>	はんだ温度 230±5 °C	はんだ浸漬時間 3±0.5 秒	使用フラックス : アルファ 100	TE 規格 109-5203	マット錫めっき品のみ	はんだ温度 235±5 °C	はんだ浸漬時間 3±0.5 秒	使用フラックス : アルファ 100	TE 規格 109-5203												
はんだ温度 230±5 °C																								
はんだ浸漬時間 3±0.5 秒																								
使用フラックス : アルファ 100																								
TE 規格 109-5203																								
マット錫めっき品のみ																								
はんだ温度 235±5 °C																								
はんだ浸漬時間 3±0.5 秒																								
使用フラックス : アルファ 100																								
TE 規格 109-5203																								

Fig. 2 (続く) (To be continued)

Para. 項目	Test Items 試験項目	Requirements 規格値	Procedures 試験方法
3.5.22	Handling Ergonomics	No abnormalities allowed in manual mating / unmating handling.	Manually operated
3.5.22	挿抜フィーリング	コネクタ挿入引抜において異常がないこと。	操作 : 手作業
Environmental Requirements 環境的性能			
3.5.23	Thermal Shock	10 mΩ Max. (Final) 10 mV / A Max. (Final)	-30°C / 120 min, 80°C / 120 min Making this a cycle, repeat 5 cycles TE Spec. 109-5103
3.5.23	熱衝撃	10 mΩ 以下 (試験後) 10 mV / A 以下 (試験後)	-30 °C/ 120 分、80°C/ 120 分 これを 1 サイクルとし 5 サイクル行う。 TE 規格 109-5103
3.5.24	Humidity, Steady State	Termination resistance (Final) 10 mV / A Max. (Final) Low Level 10 mΩ Max. Current Leakege 3 mA Max.	Mated Connector, 90~95 % R.H. 60°C 48 h TE Spec. 109-5105-2
3.5.24	耐湿性 (定常状態)	総合抵抗 10 mV / A 以下 (終期) ローレベル 10 mΩ 以下 (終期) リーク電流 3 mA 以下 (終期)	嵌合したコネクタ 90~95 % R.H. 60°C 48 時間 TE 規格 109-5105-2
3.5.25	Salt Spray	10 mΩ Max. (Final) 10 mV / A Max. (Final)	Subject mated connectors to 5 % salt concentration for 24 hours : MIL-STD-202, Method 101 TE Spec. 109-5101
3.5.25	塩水噴霧	10 mΩ 以下 (終期) 10 mV / A 以下 (終期)	5 % の塩水噴霧に 24 時間さらすこと。 TE 規格 109-5101
3.5.26	Industrial Gas (SO ₂)	10 mΩ Max. (Final) 10 mV / A Max. (Final)	SO ₂ Gas : 10 ppm, 95 % R. H. namaltenperature 24 h TE Spec. 109-5107
3.5.26	工業ガス (SO ₂)	10 mΩ 以下 (終期) 10 mV / A 以下 (終期)	SO ₂ ガス 10 ppm. 95 % R.H. 常温 24 時間 TE 規格 109-5107

Fig. 2 (続く) (To be continued)

Para. 項目	Test Items 試験項目	Requirements 規格値	Procedures 試験方法
3.5.27	Temperature Life (Heat Aging)	10 mΩ Max. (Final) 10 mV / A Max. (Final)	120°C, Duration : 120 h TE Spec. 109-5104
3.5.27	温度寿命 (耐熱)	10 mΩ 以下 (終期) 10 mV / A 以下 (終期)	120°C, 期間 120 時間 TE 規格 109-5104
3.5.28	Resistance to Cold	10 mΩ Max. (Final) 10 mV / A Max. (Final)	-50°C±5°C, 120 h TE Spec. 109-5108
3.5.28	耐寒性	10 mΩ 以下 (終期) 10 mV / A 以下 (終期)	-50°C±5°C, 120 時間 TE 規格 109-5108
3.5.29	Icing	10 mΩ Max. (Final) 10 mV / A Max. (Final)	Immerse in boiling water for 60 minutes, freeze at -30°C
3.5.29	アイシング	10 mΩ 以下 (終期) 10 mV / A 以下 (終期)	沸騰水に浸漬を 60 分 氷結温度 -30°C
3.5.30	Resistance to Oil	10 mΩ Max. (Final) 10 mV / A Max. (Final)	Immerse mated connector in oil. 50°C See Fig. 8.
3.5.30	耐油性	10 mΩ 以下 (終期) 10 mV / A 以下 (終期)	嵌会コネクタを油中に浸漬 50°C Fig. 8 参照
3.5.31	Dust Bombardment	10 mΩ Max. (Final) 10 mV / A Max. (Final)	Subject JIS R5210 cement blow 1.5 kg per 10 seconds in 15 minutes intervals for 90 minutes. TE Spec. 109-5110
3.5.31	耐塵性	10 mΩ 以下 (終期) 10 mV / A 以下 (終期)	JIS R 5210 のセメント 1.5 kg を 15 分 毎に 10 秒拡散噴射 90 分 TE 規格 109-5110

Fig. 2 (終わり) End

3.6 Product Qualification Test Sequence

Test Items 試験項目	Test Group 試験グループ(a)						
	1	2	3	4	5	6	7
	Test Sequence 試験順序 (c)						
Confirmation of Product 製品の確認検査	1	1	1	1	1	1 (b)	1,13 22
Termination Resistance (Specified Current) 総合抵抗(規定電流)	4			4, 12 15, 18 22, 25	3, 6, 9 12, 16	3, 6 9	3,9,12 16,19
Termination Resistance (Low Level) 総合抵抗(ローレベル)	3			3, 11 14, 17 21, 24	2, 5, 8 11, 15	2, 5 8	2,8,11 15, 18
Dielectric Strength 耐電圧				7			6, 20
Insulation Resistance 絶縁抵抗				6			5
Current Leakage リーク電流				5, 19	13		4, 21
Temperature Rising 温度上昇				23			
Current Cycling 電流サイクル				20			
Vibration (High Frequency) 振動(高周波)						7	
Connector Mating Force コネクタ挿入力	2			2			
Connector Unmating Force コネクタ引抜き力	5			8			
Connector Locking Strength コネクタ・ロック強度				27		11	
Contact Insertion Force コンタクト装着力			2				
Contact Retention Force コンタクト保持力				28		12	
Crimp Tensile Strength 圧着部引張強度		2					
Resistance to "Kojiri" こじり耐久性				10		4	7
Handling Ergonomics 挿抜フィーリング	6			9, 26		10	23
Thermal Shock 熱衝撃					14		
Humidity (Steady State) 耐湿性(定常状態)					10		
Salt Spray 塩水噴霧							10
Industrial SO ₂ Gas 工業ガス							14
Temperture life (Heat Aging) 温度寿命(耐熱)					4		
Resistance to Cold 耐寒性					7		
Icing アイシング				16			
Resistance to Oil 耐油性							17
Dust Bombardment 耐塵性				13			

(a) See Para 4.1

(b) Numbers indicate scquence in which tests are performed.

(c) Discontinuities shall not take place in this test group, during tests.

(a) 第 4.1 項目参照

(b) この試験グループには試験中不連続導通が発生してはならない。

(c) 欄内の数字は試験を実施する順序をしめす。

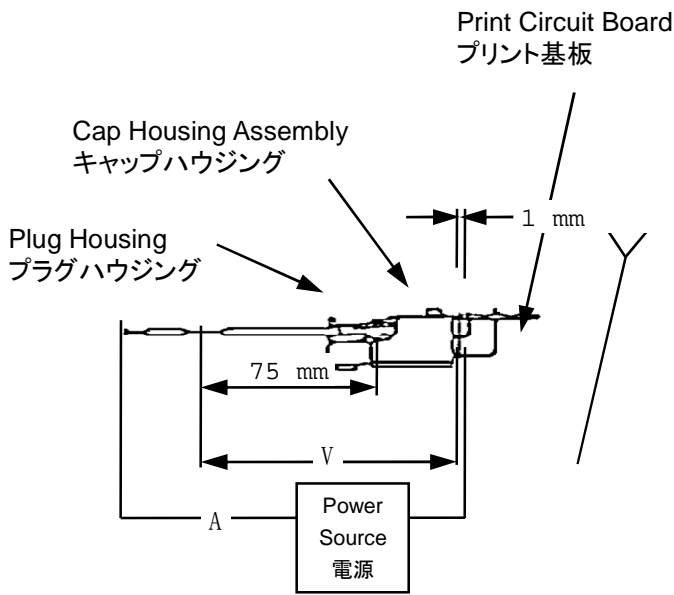

Fig. 3

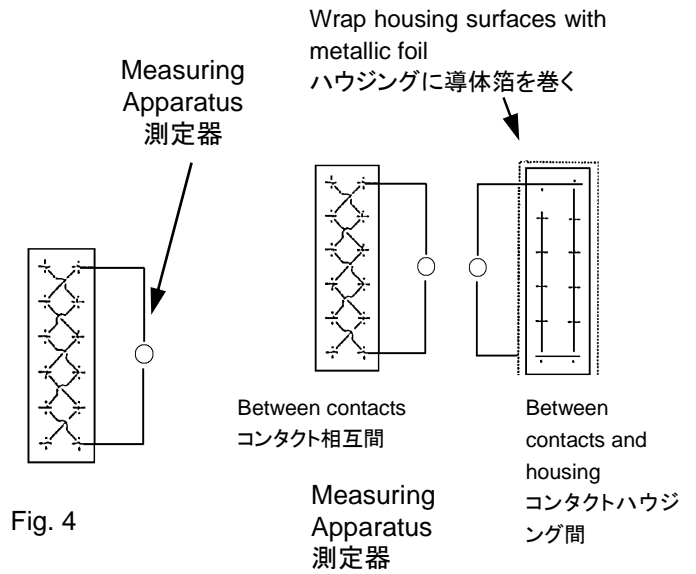

Fig. 4

Fig. 5

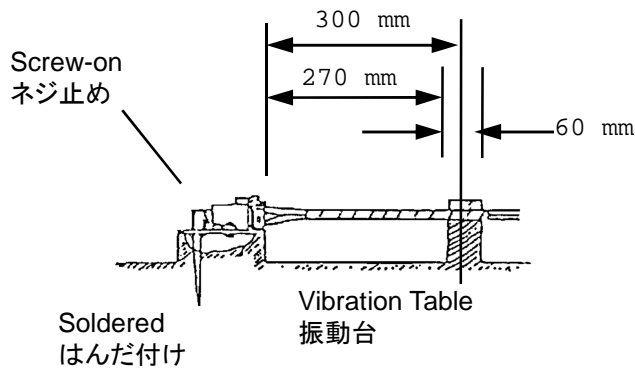

Fig.6

Wire Size 電線サイズ (mm ²)	Current Max. 電流値 (A)
0.2 mm ²	DC 6 A
0.3 mm ²	DC 8 A
0.5 mm ²	DC 11 A
0.85 mm ²	DC 15 A
1.25 mm ²	DC 19 A

No. of Pos. 極数	Reduction Coefficient 減少係数
1	1
2~3	0.75
4~5	0.6
6~8	0.55
9~12	0.5
13 & Over	0.4

通電電流 = 電流値 X 減少係数

Loaded Current = Current Max. X Reduction coefficient

Note : The acceptable current carrying capacity is obtained by the specified maximum coefficient obtained by the number of contacts above table.

注記： 通電電流は各電線サイズに対応する電流値と、極数に対応する減少係数との積から算出される。

Fig. 7

Type of oil 種類	Time of immersion 浸漬時間	Sequeunce of immersion 浸漬順序
T/C oil トルコンオイル	1 h	1
T/M oil トランスミッションオイル	1 h	3
engine oil エンジンオイル	1 h	5
cluten oil クラッチオイル	1 h	7
brake oil ブレーキオイル	1 h	9
white kerodsene 白灯油	5 min	2, 4, 6, 8, 10

Fig.8

4. Quality Assurance Provisions :

4.1. Sample Preparation

The test samples to be used for the tests shall be prepared by randomly selected from the current production, and terminated in accordance with 114-5091, Application Specification, Termination of 070 Series Receptacle Contacts.

No sample shall be reused, unless otherwise specified.

4.2. Test Conditions :

All the tests shall be performed under any combination of the following test conditions, unless otherwise specified.

Temperature : 15~35 °C

Relative Humidity : 45~75 %

Atmospheric Pressure : 86.7~107 kPa (650~800 mmHg)

4. 品質保証条件

4.1. 試料

性能試験に用いる試料は「.070 シリーズリセプタクルコンタクトの圧着条件 114-5091」に基づいて圧着した正規の試料であること。

4.2. 試験条件

特に指定のない場合は下記に示す環境条件のもとで性能試験を行うこと。

温度;15~35°C

相対湿度;45~75%

気圧;86.7~107kpa(650~800mmHg)

The applicable product descriptions and part numbers are as shown in Appendix
適用製品名と型番は付表 1 の通りである。

Appendix 1 付表 1

Part Number * 型番*	Description 名称
174921	3 Pos. Plug Housing. プラグハウジング
174922	4 Pos. Plug Housing
174923	6 Pos. Plug Housing
173850	8 Pos. Plug Housing
174464	10 Pos. Plug Housing
173851	12 Pos. Plug Housing
174481	12 Pos. Plug Housing (Combination Type for 42P) コンビネーションタイプ
173852	14 Pos. Plug Housing
173853	18 Pos. Plug Housing
174952	20 Pos. Plug Housing
175781	3 Pos. Cap Housing Horizontal Type
175783	6 Pos. Cap Housing Horizontal Type
175785	20 Pos. Cap Housing Horizontal Type
173856	8 Pos. Cap Housing Horizontal Type
174467	10 Pos. Cap Housing Horizontal Type
173858	12 Pos. Cap Housing Horizontal Type
173860	14 Pos. Cap Housing Horizontal Type
173862	18 Pos. Cap Housing Horizontal Type
173864	24 Pos. Cap Housing Horizontal Type
173866	30 Pos. Cap Housing Horizontal Type
174458	30 Pos. Cap Housing Horizontal Type (Stand Off Type)
174480	42 Pos. Cap Housing Horizontal Type (Stand Off Type) スタンドオフタイプ
174953	3 Pos. Cap Housing Vertical Type 垂直型
917048	3 Pos. Cap Housing Vertical Type (With Screw) 垂直型(ネジ付)
171581	4 Pos. Cap Housing Vertical Type
174954	6 Pos. Cap Housing Vertical Type
174955	8 Pos. Cap Housing Vertical Type
174957	12 Pos. Cap Housing Vertical Type
174960	20 Pos. Cap Housing Vertical Type
174961	30 Pos. Cap Housing Vertical Type
5175781	3 Pos. Cap Housing Horizontal Type
5174955	8 Pos. Cap Housing Vertical Type

* Note : Part number is consisted from listed base number and 1 digit numeric prefix and suffix with dash. Refer to catalog or customer drawing for specific part numbers for each base number. When prefix is zero, zero and dash are omitted.

*注記 : 型番(パーツナンバー)は、リスト中の親番号にダッシュ付きの1桁の数字をもって構成されます。各親番号に対するダッシュ付き型番の詳細は顧客用図面またはカタログを参照下さい。なお、接頭の数字がゼロの場合は、ゼロ及びダッシュは省略されます。