

THIS DRAWING IS UNPUBLISHED. RELEASED FOR PUBLICATION
 © COPYRIGHT BY TYCO ELECTRONICS CORPORATION. ALL RIGHTS RESERVED.

LOC		DIST		REVISIONS			
P	LTR	DESCRIPTION	DATE	DWN	APVD		
GP	00	L2	REVISED PER ECO-07-008164	10AUG07	JDP	CWR	

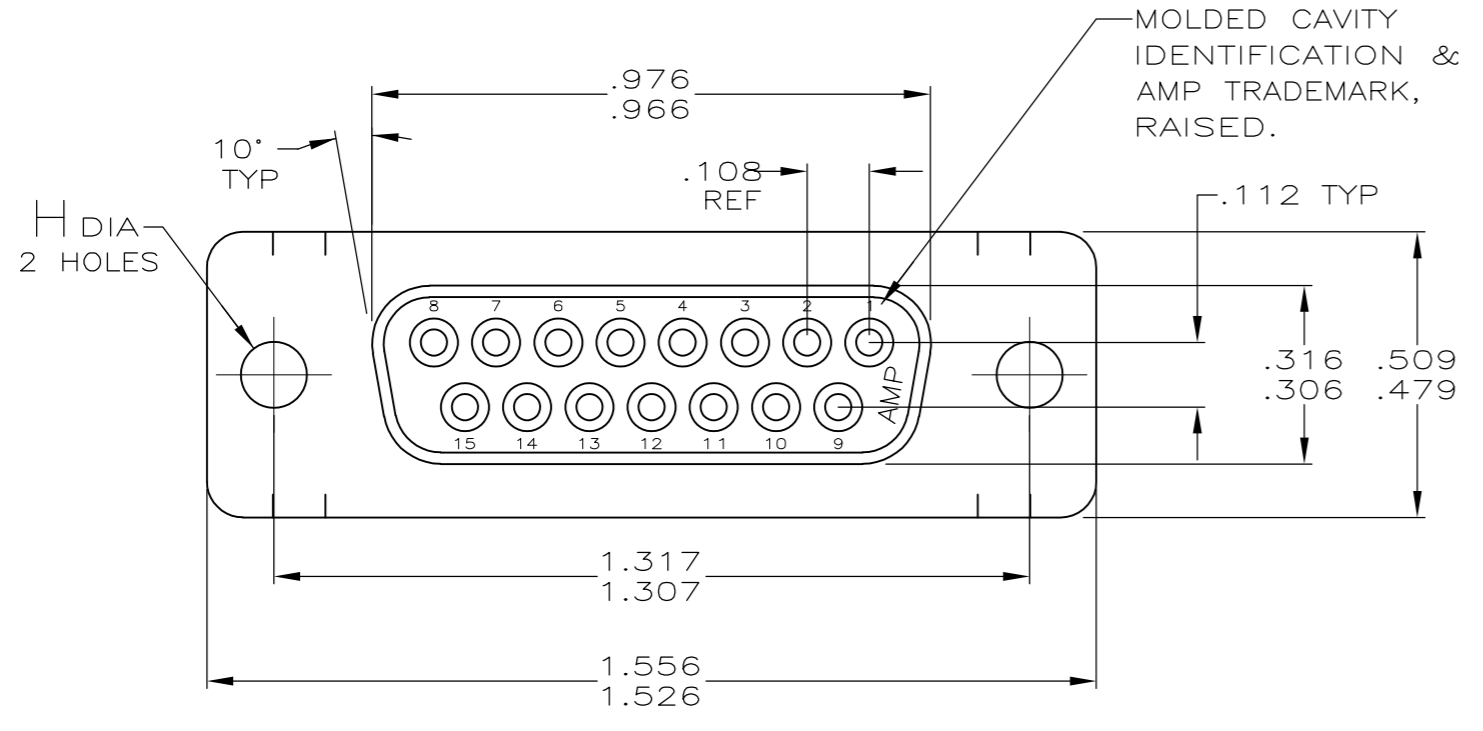

SHELL, STEEL, PER QQ-S-698 BRIGHT-TIN PLATED PER MIL-T-10727.

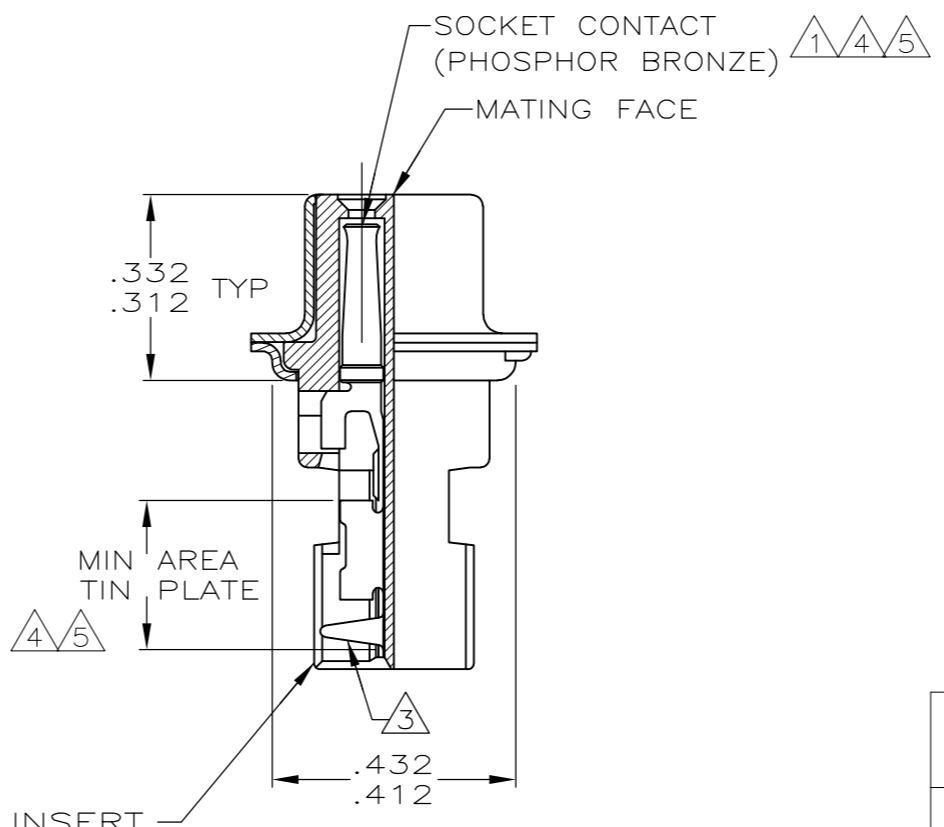
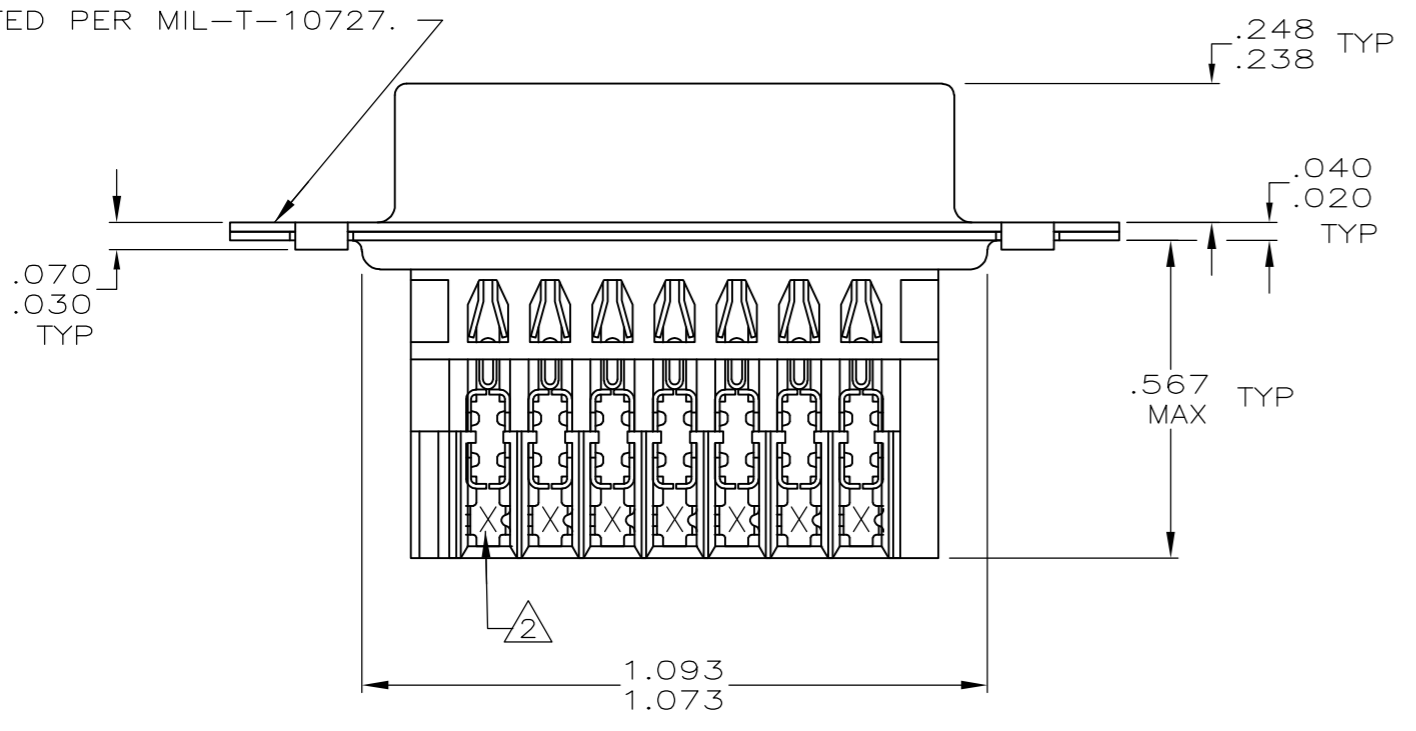

- ① HOUSING FULLY LOADED WITH CONTACTS.
- ② NUMBER ON CONTACT INDICATES WIRE RANGE.
- ③ CONTACT INSULATION RANGE: .060 MAXIMUM O.D.
- ④ .000030 GOLD ON MATING END FOR .100 MIN LENGTH. .000100-.000200 BRIGHT TIN OR BRIGHT TIN-LEAD IN AREA SHOWN. .000050 NICKEL UNDERPLATE ON ENTIRE CONTACT.
- ⑤ .000001 MIN GOLD ON MATING END FOR .100 MIN LENGTH. .000100-.000200 BRIGHT TIN OR BRIGHT TIN-LEAD IN AREA SHOWN. .000030 NICKEL UNDERPLATE ON ENTIRE CONTACT.
- ⑥ SUPERSEDED BY 745493-1
- ⑦ SUPERSEDED BY 745493-5
- ⑧ OBSOLETE
- ⑨ .000030 GOLD ON MATING END FOR .100 MIN LENGTH. .000100-.000200 MATTE TIN IN AREA SHOWN. .000050 NICKEL UNDERPLATE ON ENTIRE CONTACT.
- ⑩ .000001 MIN GOLD ON MATING END FOR .100 MIN LENGTH. .000100-.000200 MATTE TIN IN AREA SHOWN. .000030 NICKEL UNDERPLATE ON ENTIRE CONTACT.

STANDARD	SIZE	CONTACT FINISH	AWG WIRE RANGE	PART NUMBER	
STANDARD	.125 .115	⑨	1 #26-30	1-745493-6	
STANDARD	.125 .115	⑩	2 #22-26	1-745493-5	
STANDARD	.125 .115	⑨	2 #22-26	1-745493-4	
SMALL PACK	.125 .115	⑤	2 #22-26	⑦ 1-745493-3	
STANDARD	.156 .146	⑤	3 #20-22	⑧ 1-745493-2	
			2 #22-26	⑧ 1-745493-1	
			1 #26-30	⑧ 1-745493-0	
STANDARD	.156 .146	④	3 #20-22	⑧ 745493-9	
			2 #22-26	⑧ 745493-8	
			1 #26-30	⑧ 745493-7	
STANDARD	.125 .115	⑤	3 #20-22	⑧ 745493-6	
			2 #22-26	⑧ 745493-5	
			1 #26-30	⑥ 745493-4	
STANDARD	.125 .115	④	3 #20-22	⑧ 745493-3	
			2 #22-26	⑧ 745493-2	
			1 #26-30	⑧ 745493-1	
PACKAGING	H	CONTACT FINISH	②	AWG WIRE RANGE	PART NUMBER

THIS DRAWING IS A CONTROLLED DOCUMENT.

DIMENSIONS: INCHES	TOLERANCES UNLESS OTHERWISE SPECIFIED:	DWN L. VARELA - DOCK5 11-16-04	CHK J. GERACE 11-16-04	Tyco Electronics Corporation Harrisburg, PA 17105-3608	
	0 PLC ± -	APVD M. WALMSLEY 11-16-04	NAME RECEPTACLE ASSEMBLY, METAL SHELL, SIZE 2, 15 POSITION, SERIES HDE-20 FOR MASS TERMINATION		
	1 PLC ± -	PRODUCT SPEC 108-40011	SIZE A2	CAGE CODE 00779	DRAWING NO C=745493
MATERIAL SEE CALL OUT	FINISH SEE TABLE	2 PLC ± -	RESTRICTED TO -		
		3 PLC ± -	WEIGHT -	SCALE 3:1	SHEET 1 OF 1
		4 PLC ± .005	CUSTOMER DRAWING		
		4 ANGLES ± 2°	REV L2		