

2. Applicable Documents :

The following documents form a part of this specification to the extent specified herein. In the event of conflict between the requirements of this specification and the product drawing, the product drawing shall take precedence. In the event of conflict between the requirements of this specification and the referenced documents, this specification shall take precedence.

2.1 AMP Specifications :

114-5094, 5162 Application Specification, .040 Series Receptacle Contact

114-5109 Application Specification, .070 Series Receptacle Contact

2.2 Military Standard and Specifications :

MIL-STD-202 Test Methods for Electronic and Electrical Component Parts
208 : Test Method for Soldering of Parts

3. Requirements :

3.1 Design and Construction :

Product shall be of the design, construction and physical dimensions specified in the applicable product drawing.

3.2 Materials :

A. Contact :

Tab Contact - Pre-tinned brass strip, or plain brass strip with selective gold plating over nickel underplate.

Receptacle Contact - Pre-tinned phosphor bronze strip, or plain phosphor bronze strip with selective gold plating over nickel underplating.

B. Housing :

Plug Housing and Cap Housing - Polybutylene terephthalate

Wire Cover - Polypropylene

C. Accessories and Hardware :

Bolt, Nut and Washer - Steel

| | | | | |
|---|------------|----------|-----------------|-------------------|
| SHEET | AMP | | | AMP (Japan), Ltd. |
| | | | | Kawasaki, Japan |
| 2 OF 8 | LOC J | LOC A | NO. 108-5301 | REV. 0 |
| NAME .040 SERIES CENTER LOCK CONNECTOR | | | | |

108-5301

NUMBER:

CUSTOMER
RELEASE

SECURITY
CLASSIFICATION:

3.3 Temperature Rating (Mated condition)
- 30 °C to 105 °C (Including temperature rising in addition to the ambient temperature)

3.4 Performance and Test Descriptions :

The product shall be designed to meet the electrical, mechanical and environmental performance requirements specified in Fig. 2. All tests shall be performed in the room temperature unless otherwise specified.

3.5 Test Requirements and Procedures Summary :

| Para. | Test Items | Requirements | Procedures |
|-------------------------|------------------------------------|---|--|
| 3.5.0 | Confirmation of Product | Product shall be conforming to the requirements of applicable product drawing and Application Specification 114-5094, -5162, -5109. | Visually, dimensionally and functionally inspected per applicable inspection plan. |
| Electrical Requirements | | | |
| 3.5.1 | Termination Resistance (Low Level) | .040 10 mΩ max. (Initial) 20 mΩ max. (Final) .070 3 mΩ max. (Initial) 10 mΩ max. (Final) | Subject mated contacts assembled in housing to closed circuit current of 10 mA max. at open circuit voltage of 20 mV max. Fig. 3. |
| 3.5.2 | Dielectric Strength | Connector must withstand test potential of 1 kVAC for 1 minute. | Measure by applying test potential between the adjacent contacts, and between the contacts and ground in the mated connectors. Fig. 4 |
| 3.5.3 | Insulation Resistance | 100 MΩ min. (Initial) 100 MΩ min. (Final) | Measure by applying test potential between the adjacent contacts, and between the contacts and ground in the mated connector. Condition DC 500 V Fig. 4 |

Fig. 2 (To be continued)

| | | | | |
|---|------------|----------|--------------------------------------|-----------|
| SHEET 3 OF 8 | AMP | | AMP (Japan), Ltd. Kawasaki, Japan | |
| | LOC J | LOC A | NO. 108-5301 | REV. 0 |
| NAME .040 SERIES CENTER LOCK CONNECTOR | | | | |

108-5301

NUMBER:

Customer Release

RELIABILITY CLASSIFICATION:

| Para. | Test Items | Requirements | Procedures | | | | | | | | | | | | |
|-------|-------------------------|--|--|-----------|-----------|-----------|-----------|------|------|------|---------------------|------|------|------|----------------------|
| 3.5.4 | Current Leakage | 10 μ A max. (Initial) 1 mA max. (Final) | After exposing mated connector in test chamber (60 ± 5 °C, 90-95 % R.H.) for 1 hour, measure by applying DC 13 V to the circuit. See Fig. 5 | | | | | | | | | | | | |
| 3.5.5 | Temperature Rising | 30 °C max. under loaded specified current. | After having a half number of the contacts series-wired, apply the specified current to the connector in the draft-free test chamber, and after reaching the stabilized temperature, measure the temperature of the wire crimp of the contact. .040-5 A (0.5 mm ² wire) .070-10 A (1.25 mm ² wire) | | | | | | | | | | | | |
| 3.5.6 | Current Cycling | Termination resistance (low level) .040 20 m Ω max. (Final) .070 10 m Ω max. (Final) | After having a half number of contacts series-wired, apply the following test current for 45 minutes and deenergize for 15 minutes, in ambient temperature of 60 °C, making this a cycle, repeat for 1,000 cycles. .040-5 A (0.5 mm ² wire) .070-10 A (1.25 mm ² wire) | | | | | | | | | | | | |
| 3.5.7 | Fuse Matching Ability | Fusion of the housing or ignition of the connector must not occur. | After having a half number of contacts series-wired, apply the test current "α" for 24 hours, then apply current "β" for 1 hour. | | | | | | | | | | | | |
| | | | <table border="1"> <thead> <tr> <th></th> <th>Current α</th> <th>Current β</th> <th>Wire Size</th> </tr> </thead> <tbody> <tr> <td>.040</td> <td>11 A</td> <td>14 A</td> <td>0.5 mm²</td> </tr> <tr> <td>.070</td> <td>22 A</td> <td>27 A</td> <td>1.25 mm²</td> </tr> </tbody> </table> | | Current α | Current β | Wire Size | .040 | 11 A | 14 A | 0.5 mm ² | .070 | 22 A | 27 A | 1.25 mm ² |
| | | | | Current α | Current β | Wire Size | | | | | | | | | |
| .040 | 11 A | 14 A | 0.5 mm ² | | | | | | | | | | | | |
| .070 | 22 A | 27 A | 1.25 mm ² | | | | | | | | | | | | |
| | | | | | | | | | | | | | | | |
| 3.5.8 | Contact Engaging, Force | .040 0.98~5.88 N (0.1~0.6 kgf) .070 1.96~7.84 N (0.2 ~0.8 kgf) | Operation Speed : 100 mm / minute | | | | | | | | | | | | |

Fig. 2 (To be continued)

| | | | | |
|-----------------------------------|------------|----------|----------|--------------------------------------|
| SHEET | AMP | | | AMP (Japan), Ltd. Kawasaki, Japan |
| | 4 OF 8 | LOC J | LOC A | NO. 108-5301 |
| NAME | | | | REV. 0 |
| .040 SERIES CENTER LOCK CONNECTOR | | | | |

| | | | | | | |
|---|--------|---------------------------------------|--|------------------------------|---|----|
| NUMBER: 108-5301 SECURITY CLASSIFICATION: Customer Release | Para. | Test Items | Requirements | | Procedures | |
| | 3.5.9 | Contact Separating Force | .040 | 0.98~5.88 N (0.1~0.6 kgf) | Operation Speed : 100 mm / minute | |
| | | .070 | 1.96~7.84 N (0.2 ~0.8 kgf) | | | |
| | 3.5.10 | Tightening Torque of Bolt | 4.9 N · m {50 kgf · cm} Max. | | After connector to be pre-locked, tight bolt until fully mated and measure the maximum torque. | |
| Physical Requirements | | | | | | |
| | 3.5.11 | Contact Retention Force | 49 N (5 kgf) Min. | | Apply an axial pull off load to crimped wire. Operation Speed : 100 mm / minute | |
| | 3.5.12 | Contact Retention Force | 98 N (10 kgf) Min. | | Measure contact retention force with secondary lock set in effect. Operation Speed : 100 mm / minute | |
| | 3.5.13 | Crimp Tensile Strength | Wire Size | | Crimp Tensile (min.) | |
| | | | mm ² | (AWG) | | N |
| | | | 0.3 | #22 | 58.8 | 6 |
| | | | 0.5 | #20 | 88.2 | 9 |
| | | | 0.85 | #18 | 127.4 | 13 |
| | | | 1.25 | #16 | 166.6 | 17 |
| | | | 2 | #14 | 196 | 20 |
| | 3.5.14 | Durability (Repeated Mate / Unmating) | Termination Resistance (Low Level) (Final) .040 20 mΩ Max. .070 10 mΩ Max. | | No. of Cycles : 50 cycles | |

Fig. 2 (To be contend)

| | | | | |
|---|---|----------|-----------------|-----------|
| SHEET | AMP AMP (Japan), Ltd. Kawasaki, Japan | | | |
| 5 OF 8 | LOC J | LOC A | NO. 108-5301 | REV. 0 |
| NAME .040 SERIES CENTER LOCK CONNECTOR | | | | |

108-5301

NUMBER:

Customer
ReleaseSECURITY
CLASSIFICATION:

| Para. | Test Items | Requirements | Procedures |
|--------|--|---|--|
| 3.5.15 | Vibration Sinusoidal Low Frequency | No electrical discontinuity greater than 10 microsecond (s) shall occur. Termination Resistance (Low Level) (Final) .040 20 mΩ Max. .070 10 mΩ Max. | Connect serially all poles of the connector, and give vibration after DC 12 V 0.1 A is energized. Vibration accelation : 66.7 m/s ² (6.8 G) Vibration frequency : 10-50-10 Hz Cycle / min. Duration : Up and down directions for 4 hours as shown in figure 6, and in forward and rearward directions for 2 hours respectively. |
| 3.5.16 | Solderability | Solderable area shall have a solder coverage of 95 % minimum. (However, excepting sheared surface) | After immersing a soldering area of the cap assembly posts in flux (rosineous methanol solution) for 5 to 10 seconds, immerse it in a soldering bath of 230 °C ± 5 °C (tin 60 %, lead 40 %) for 3 ± 0.5 seconds, and then inspect the connector by using approx X10 magnifying glass. |
| 3.5.17 | Temperature Life (Heat Aging) | Termination resistance (Low Level) (Final) .040 20 mΩ Max. .070 10 mΩ Max. | Subject mated connectors to exposure of 100 °C for 24 hours. |
| 3.5.18 | Resistance to Cold | Termination resistance (Low Level) (Final) .040 20 mΩ Max. .070 10 mΩ Max. | Subject mated connectors to exposure of - 40 °C for 24 hours. |
| 3.5.19 | Humidity, Steady State | Termination resistance (Low level) (Final) .040 20 mΩ Max. .070 10 mΩ Max. Current Leakage (Final) : 1 mA max. Insulation resistance (Final) : 100 MΩ min. | Mated Connector, 90~95 % R.H., 40 °C 96 hours. |

Fig. 2 (To be continued)

| | | | | |
|---|------------|----------|----------|--------------------------------------|
| SHEET | AMP | | | AMP (Japan), Ltd. Kawasaki, Japan |
| | 6 OF 8 | LOC J | LOC A | NO. 108-5301 |
| REV. 0 | | | | |
| NAME .040 SERIES CENTER LOCK CONNECTOR | | | | |

| SECURITY CLASSIFICATION: Customer Release | NUMBER: 108-5301 | Para. 3.5.20 Test Items: Dust Bombardment Requirements: Termination resistance (Low Level) .040 20 mΩ Max. .070 10 mΩ Max. | Procedures: Subject mated connectors to a spray of Portland cement (JIS R 5210) propelled by compressed air at a rate of 1.5 kg in 10 seconds in every 15 minutes, in a closed chamber of 1,000 mm cube with the sample connector hung 150 mm away the chamber wall. This test must be continued for 1 hour, and after completion of this test, repeat insertion and extraction for 3 cycles. | | | | | | | | | | | | | | | | | | | | | | | | | | | | | | | | | | | | | | | | |
|---|---|---|--|--------------------|--------------------|--------------------|--|---------|---------|---|------|--------|---|--|----------------|------------|---------|--|---|-----------|------------|-------|---|---|---|------------|-------|---|---|--|------------|-------|---|---|--------------|------------|-------|---|---|----------|------------|--------|-------------|
| | Para. 3.5.21 Test Items: Resistance to Oil and Liquid Requirements: Termination resistance (Low Level) (Final) .040 20 mΩ Max. .070 10 mΩ Max. No abnormalities in the appearance | <table border="1"> <thead> <tr> <th rowspan="2">Kinds</th> <th rowspan="2">Liquid Temperature</th> <th rowspan="2">Immersion Duration</th> <th colspan="2">Immersion Sequence</th> </tr> <tr> <th>Group A</th> <th>Group B</th> </tr> </thead> <tbody> <tr> <td>Mixed Solution of Equal Mixing Ratio of Engine Oil & Kerosene</td> <td>50°C</td> <td>2 hrs.</td> <td>1</td> <td></td> </tr> <tr> <td>Motor Gasoline</td> <td>Room Temp.</td> <td>10 mins</td> <td></td> <td>1</td> </tr> <tr> <td>Brake Oil</td> <td>Room Temp.</td> <td>1 hr.</td> <td>3</td> <td>3</td> </tr> <tr> <td>Coolant Anti-freeze Liquid (5 % aqueous solution)</td> <td>Room Temp.</td> <td>1 hr.</td> <td>5</td> <td>5</td> </tr> <tr> <td>Cooling Water Anti-freeze Liquid (50 % aqueous solution)</td> <td>Room Temp.</td> <td>1 hr.</td> <td>7</td> <td>7</td> </tr> <tr> <td>Washer Fluid</td> <td>Room Temp.</td> <td>1 hr.</td> <td>9</td> <td>9</td> </tr> <tr> <td>Kerosene</td> <td>Room Temp.</td> <td>5 mins</td> <td>2·4 ·6·8</td> <td>2·4 ·6·8</td> </tr> </tbody> </table> <p>Note: Engine oil : SAE 10 W Kerosene : JIS K 2203 No. 2 Motor gasoline : JIS K 2202 For other tests, use genuine car manufacture's liquid products.</p> | Kinds | Liquid Temperature | Immersion Duration | Immersion Sequence | | Group A | Group B | Mixed Solution of Equal Mixing Ratio of Engine Oil & Kerosene | 50°C | 2 hrs. | 1 | | Motor Gasoline | Room Temp. | 10 mins | | 1 | Brake Oil | Room Temp. | 1 hr. | 3 | 3 | Coolant Anti-freeze Liquid (5 % aqueous solution) | Room Temp. | 1 hr. | 5 | 5 | Cooling Water Anti-freeze Liquid (50 % aqueous solution) | Room Temp. | 1 hr. | 7 | 7 | Washer Fluid | Room Temp. | 1 hr. | 9 | 9 | Kerosene | Room Temp. | 5 mins | 2·4 ·6·8 |
| Kinds | Liquid Temperature | Immersion Duration | | | | Immersion Sequence | | | | | | | | | | | | | | | | | | | | | | | | | | | | | | | | | | | | | |
| | | | Group A | Group B | | | | | | | | | | | | | | | | | | | | | | | | | | | | | | | | | | | | | | | |
| Mixed Solution of Equal Mixing Ratio of Engine Oil & Kerosene | 50°C | 2 hrs. | 1 | | | | | | | | | | | | | | | | | | | | | | | | | | | | | | | | | | | | | | | | |
| Motor Gasoline | Room Temp. | 10 mins | | 1 | | | | | | | | | | | | | | | | | | | | | | | | | | | | | | | | | | | | | | | |
| Brake Oil | Room Temp. | 1 hr. | 3 | 3 | | | | | | | | | | | | | | | | | | | | | | | | | | | | | | | | | | | | | | | |
| Coolant Anti-freeze Liquid (5 % aqueous solution) | Room Temp. | 1 hr. | 5 | 5 | | | | | | | | | | | | | | | | | | | | | | | | | | | | | | | | | | | | | | | |
| Cooling Water Anti-freeze Liquid (50 % aqueous solution) | Room Temp. | 1 hr. | 7 | 7 | | | | | | | | | | | | | | | | | | | | | | | | | | | | | | | | | | | | | | | |
| Washer Fluid | Room Temp. | 1 hr. | 9 | 9 | | | | | | | | | | | | | | | | | | | | | | | | | | | | | | | | | | | | | | | |
| Kerosene | Room Temp. | 5 mins | 2·4 ·6·8 | 2·4 ·6·8 | | | | | | | | | | | | | | | | | | | | | | | | | | | | | | | | | | | | | | | |

Fig. 2 (end)

| | | | | |
|---|---|----------|----------|-----------------|
| SHEET | AMP AMP (Japan), Ltd. Kawasaki, Japan | | | |
| | 7 OF 8 | LOC J | LOC A | NO. 108-5301 |
| NAME .040 SERIES CENTER LOCK CONNECTOR | | | | |

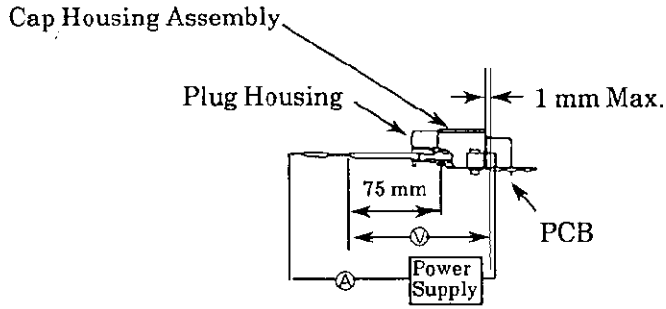

Fig. 3

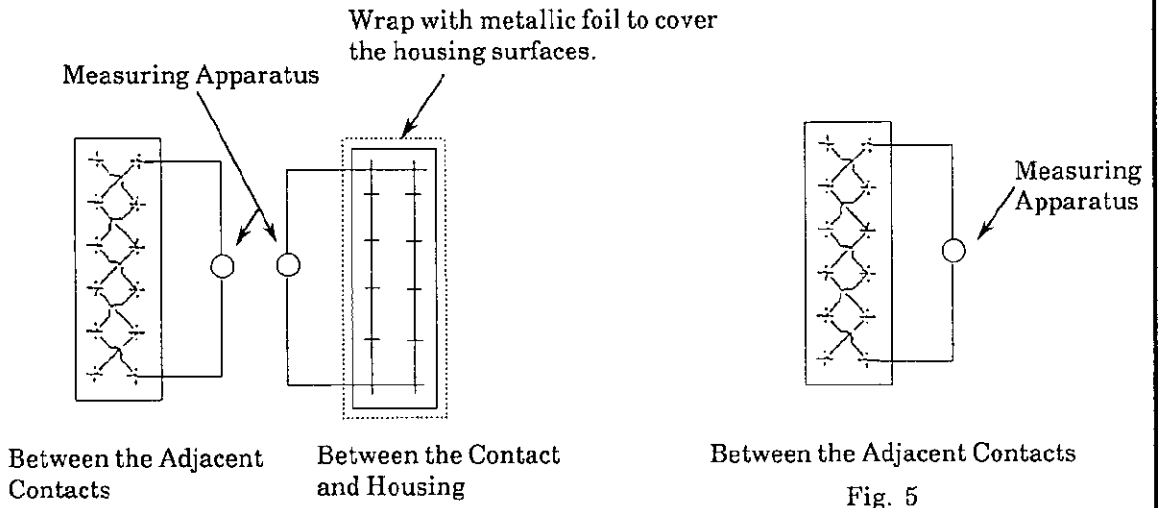

Fig. 4

Fig. 5

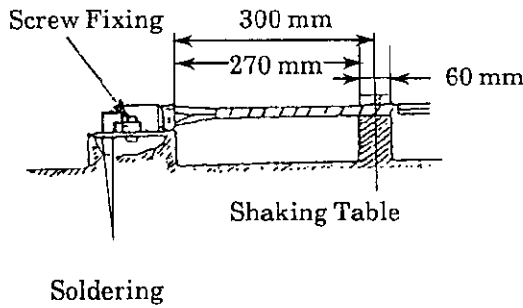

Fig. 6

| | | | | |
|---|------------|----------|--------------------------------------|-----------------|
| SHEET | AMP | | AMP (Japan), Ltd. Kawasaki, Japan | |
| | 8 OF 8 | LOC J | LOC A | NO. 108-5301 |
| | | | | REV. 0 |
| NAME .040 SERIES CENTER LOCK CONNECTOR | | | | |