

REVISIONS				
P.	LTN	DESCRIPTION	DATE	APP'D
A4		REVISED PER ECO-12-009257	29MAY2012	DD DS
A5		REVISED PER ECO-13-020287	16JAN2014	DD DS

- 1 ACCEPTS #4 SELF TAPPING THREAD FORMING SCREWS OR METRIC EQUIVALENT. DRIVE TO 0.4 N-m MINIMUM
- 2 DATE CODE TO BE BRANDED IN THIS LOCATION PER TE SPEC 102-60. USE 5 DIGIT CODE: FIRST 2 DIGITS = YEAR, SECOND 2 DIGITS = WEEK, LAST DIGIT = DAY.
- 3 MATERIALS: HEADER HOUSING - GLASS FILLED PBT
PINS - TIN OR GOLD PLATED BRASS
GASKET - SILICONE
- 4 HOUSING COLORS ARE MECHANICALLY KEYED TO MATE ONLY WITH IDENTICALLY COLORED PLUG ASSEMBLIES.
- 5. HEADER MATES TO PLUG ASSEMBLY 776273 WHICH USES REELED TERMINAL 770520 OR LOOSE PIECE TERMINAL 770854

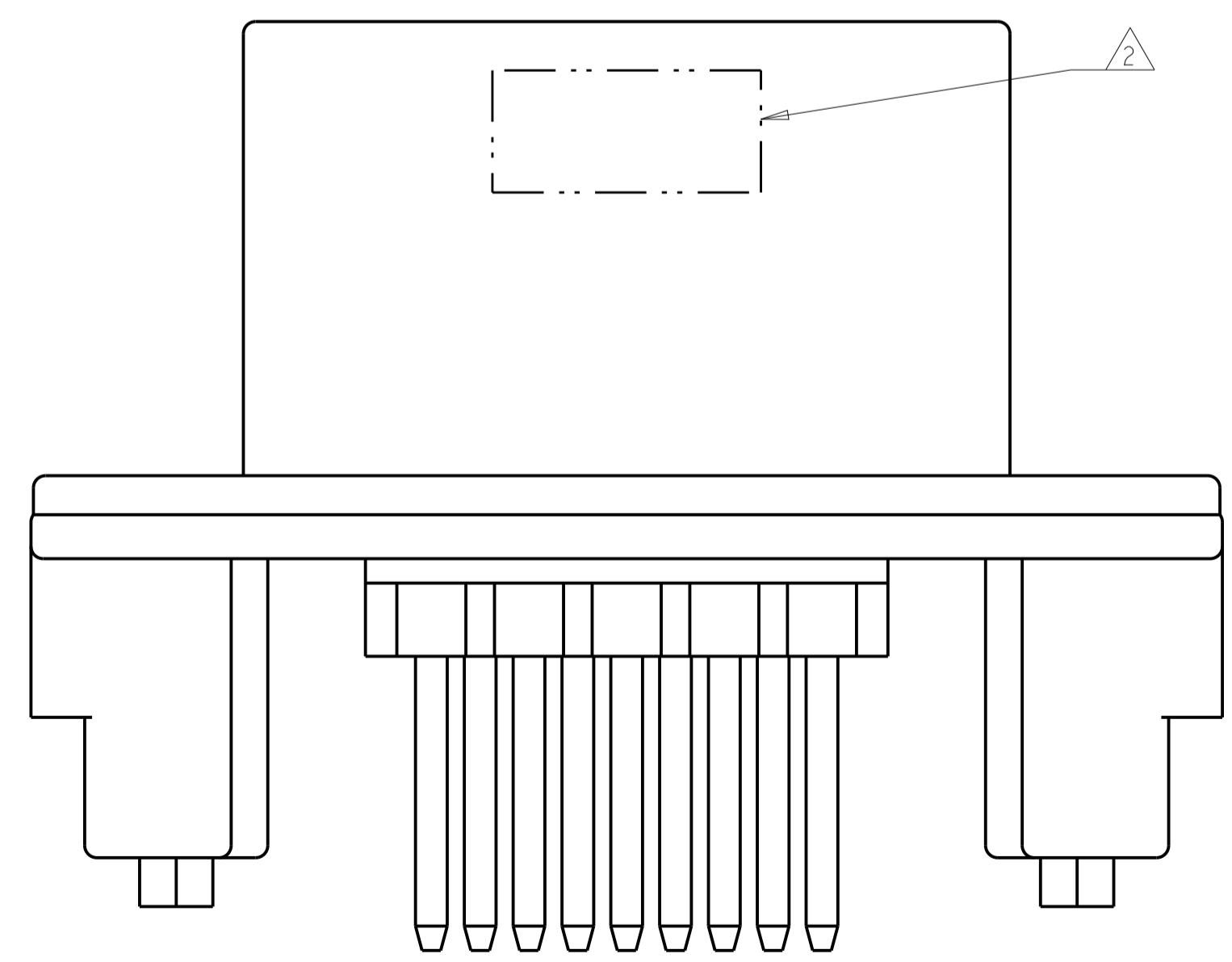
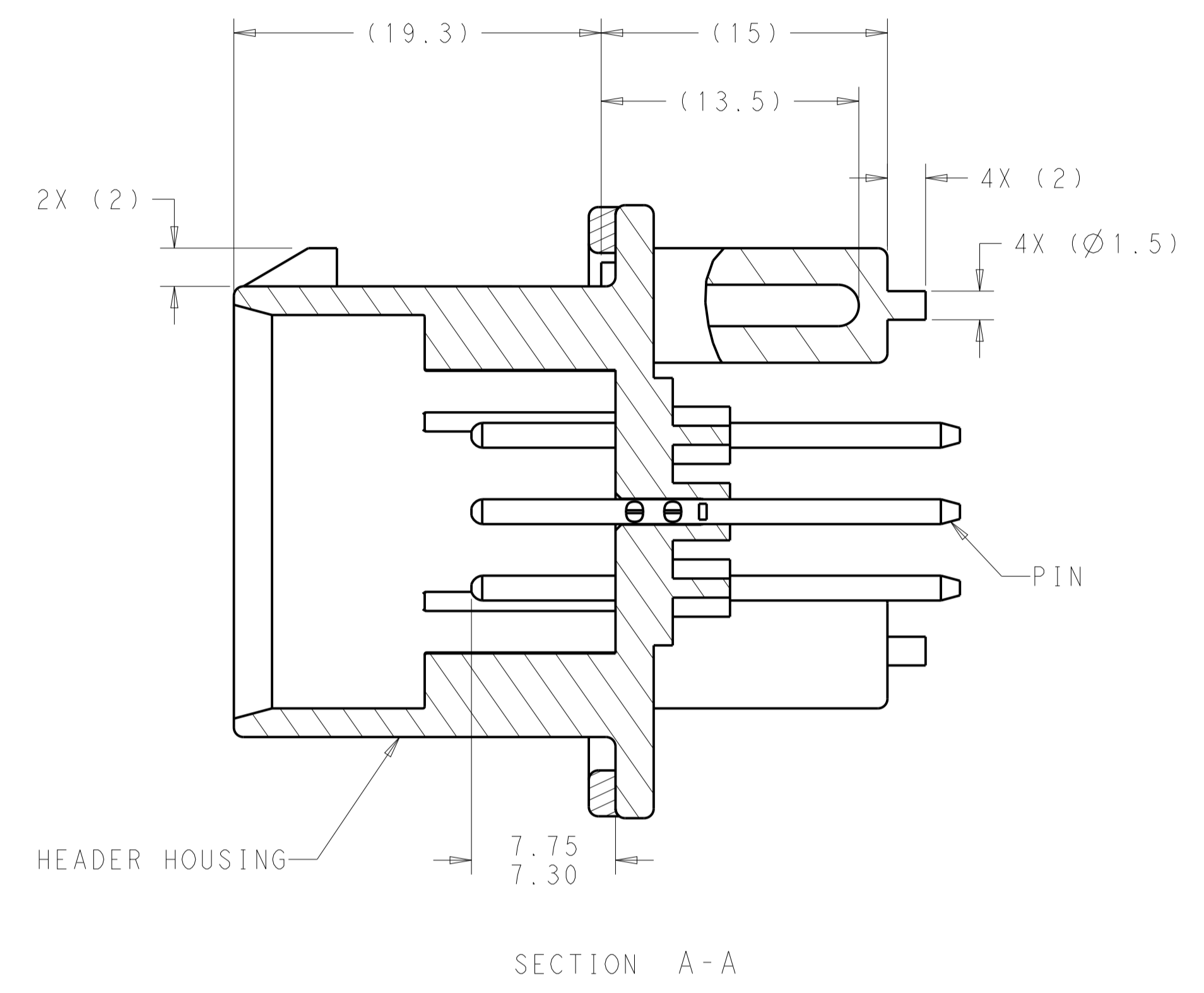
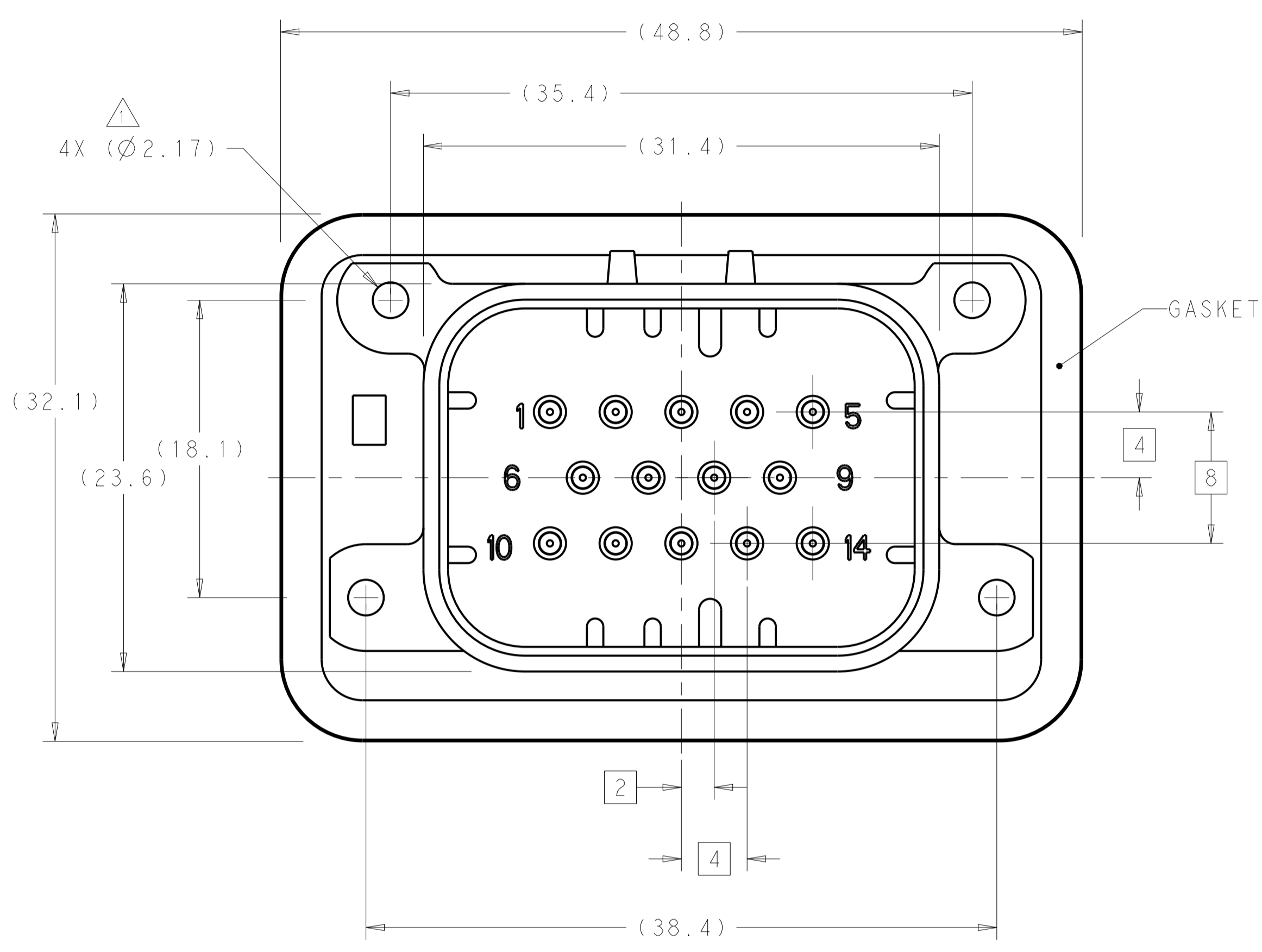

776262-1 & 1-776262-1 SHOWN

BLUE	DURAGOLD	1-776262-5
GRAY	DURAGOLD	1-776262-4
NATURAL	DURAGOLD	1-776262-2
BLACK	DURAGOLD	1-776262-1
BLUE	TIN	776262-5
GRAY	TIN	776262-4
NATURAL	TIN	776262-2
BLACK	TIN	776262-1
HEADER COLOR	PLATING	PART NUMBER

THIS DRAWING IS A CONTROLLED DOCUMENT.		OWN: D. STRAUSSER 03MAR2010	TE Connectivity	
DIMENSIONS: mm		CHK: D. STRAUSSER 22MAR2010		
TOLERANCES UNLESS OTHERWISE SPECIFIED:		APVD: D. STRAUSSER 27APR2010		
0 PLC ±0.2	1 PLC ±0.13	PRODUCT SPEC 108-1329	NAME ASSEMBLY, HEADER, 14 POSITION, VERTICAL, AMPSEAL WITH FLANGE SEAL	
2 PLC ±0.13	3 PLC ±0.13	APPLICATION SPEC 114-16016	SIZE CAGE CODE DRAWING NO. RESTRICTED TO	
4 PLC ±0.13	ANGLES ±0.4°	WEIGHT	A100779C=776262	
MATERIAL	FINISH	CUSTOMER DRAWING	SCALE 4:1	SHEET 1 OF 2

REVISIONS				
P.	LTH	DESCRIPTION	DATE	APVD
-	-	SEE SHEET 1	-	-

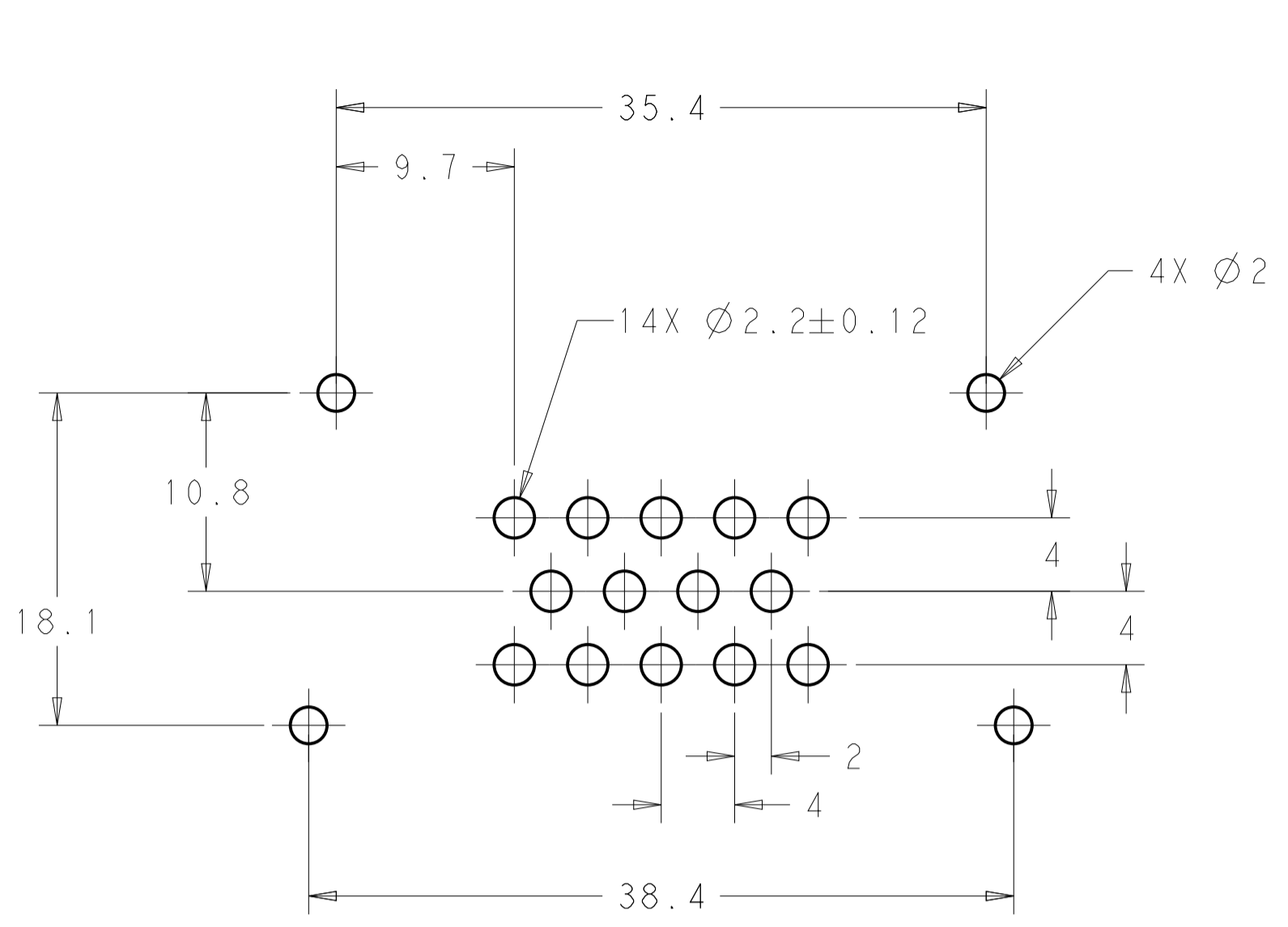

RECOMMENDED P.C. BOARD LAYOUT FOR 1.57 THICK P.C. BOARD

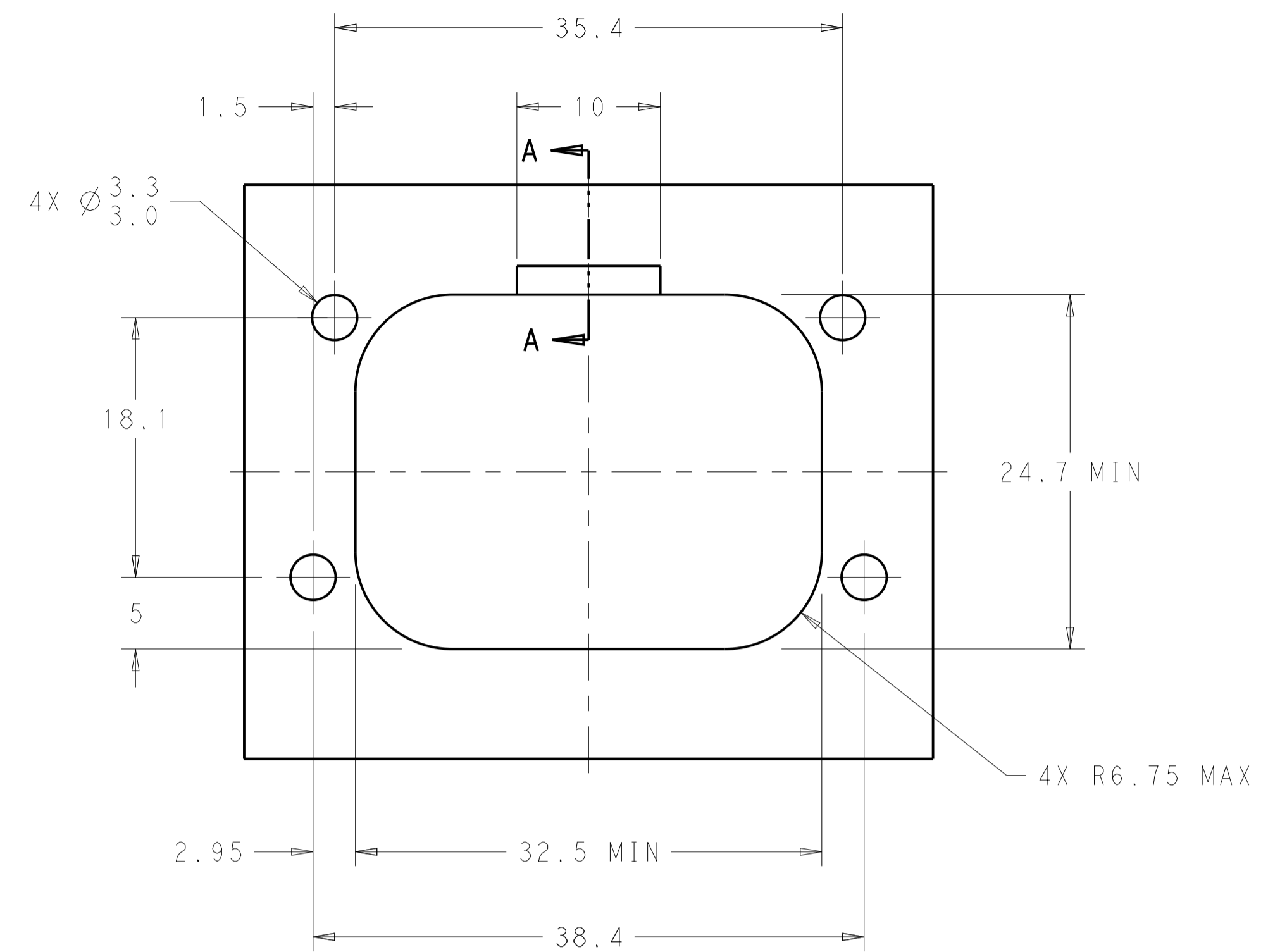

RECOMMENDED MOUNTING HOLE LAYOUT FOR 5.0 MAX THICK PANEL

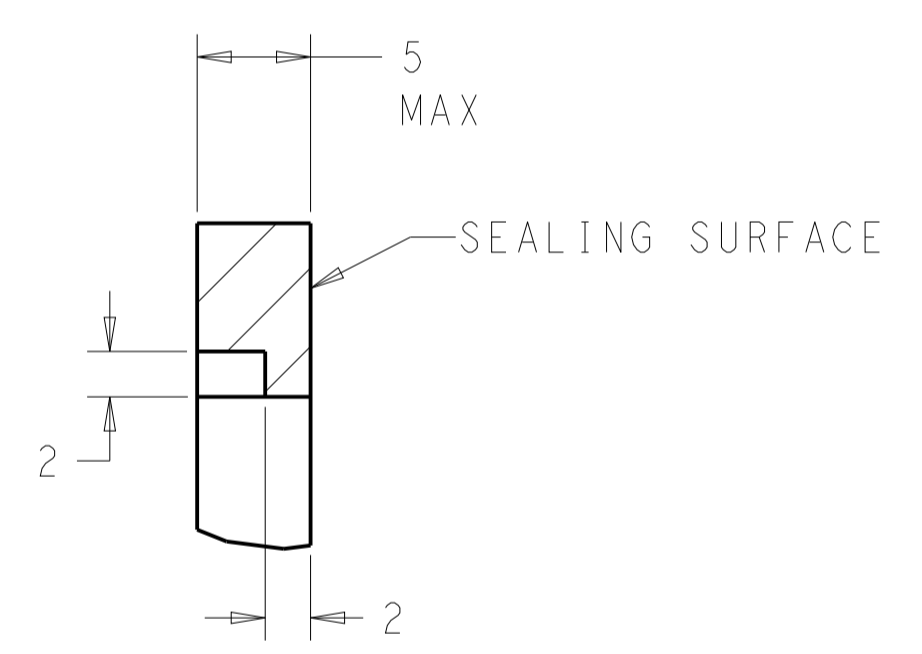

SECTION A-A OPTIONAL CONSTRUCTION IF PANEL THICKNESS IS GREATER THAN 2.0

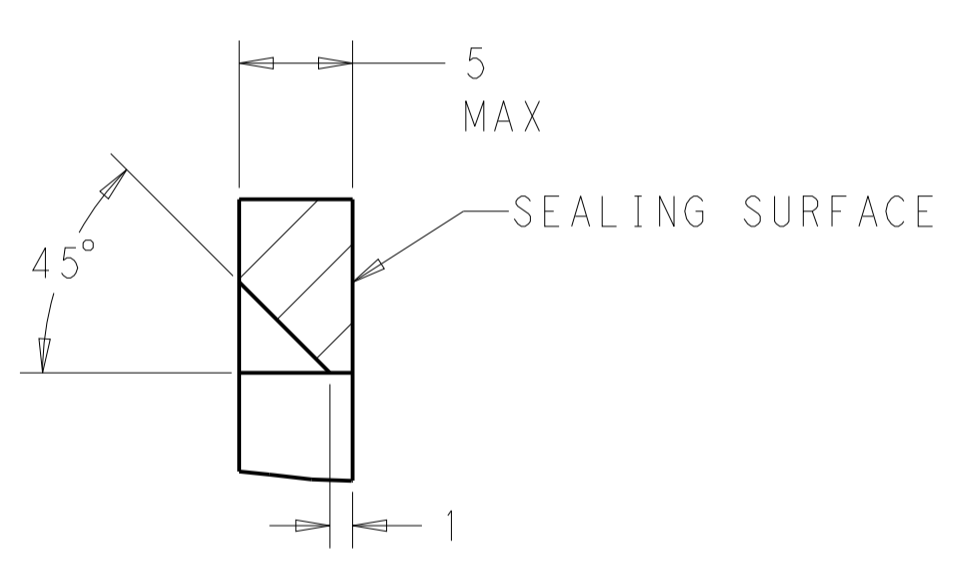

SECTION A-A OPTIONAL CONSTRUCTION IF PANEL THICKNESS IS GREATER THAN 2.0

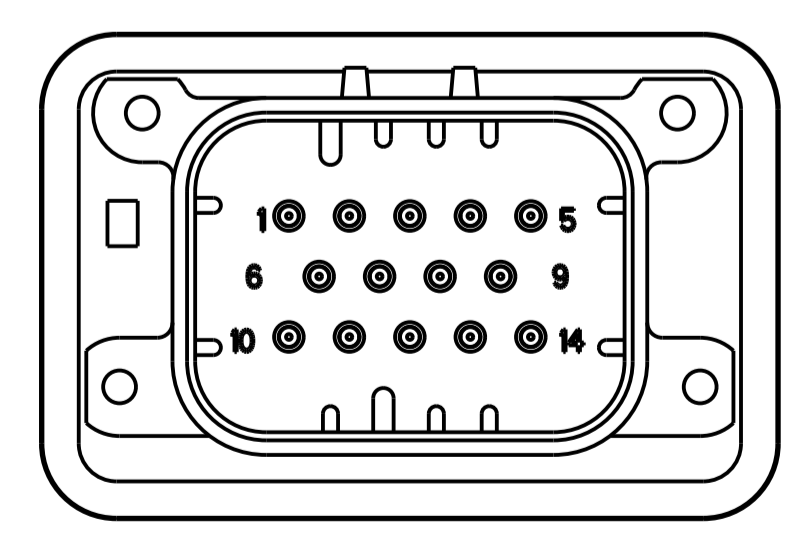

776262-2 & 1-776262-2 KEY LOCATION SCALE 2:1

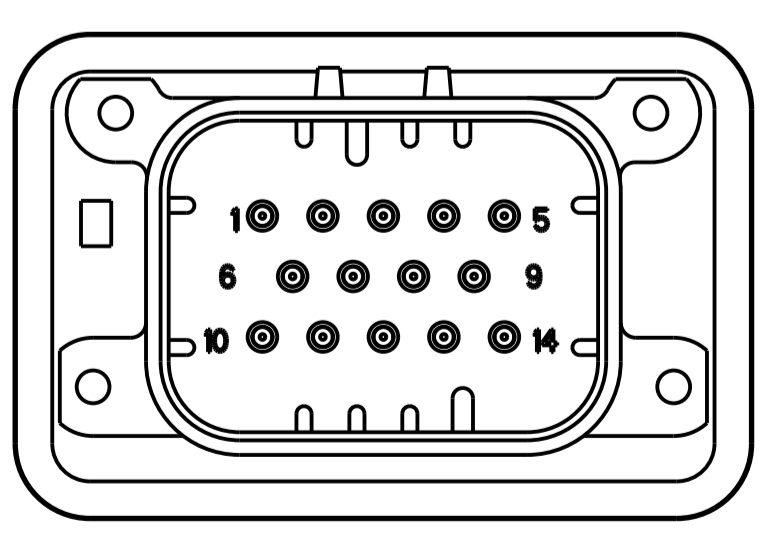

776262-4 & 1-776262-4 KEY LOCATION SCALE 2:1

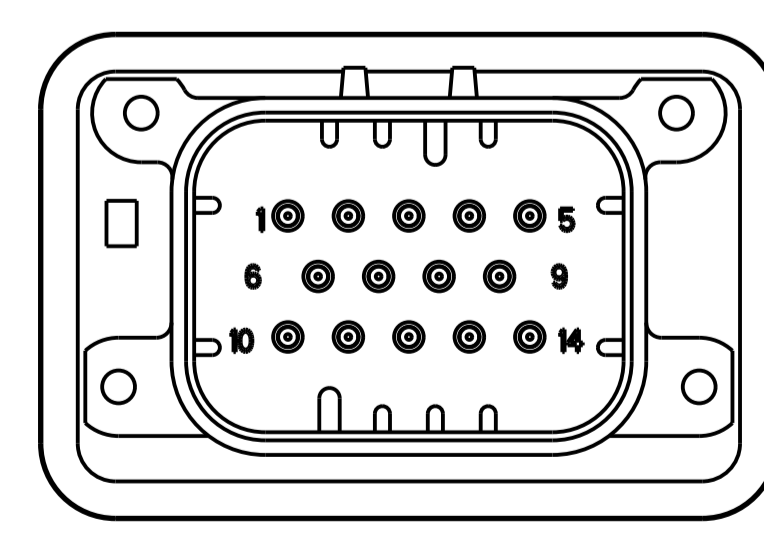

776262-5 & 1-776262-5 KEY LOCATION SCALE 2:1

THIS DRAWING IS A CONTROLLED DOCUMENT.		OWN: D. STRAUSSER 03MAR2010	TE Connectivity
DIMENSIONS: mm		CHK: D. STRAUSSER 22MAR2010	
TOLERANCES UNLESS OTHERWISE SPECIFIED:		APVD: D. STRAUSSER 27APR2010	NAME: ASSEMBLY, HEADER, 14 POSITION, VERTICAL, AMPSEAL WITH FLANGE SEAL
0 PLC ±0.2	1 PLC ±0.13	PRODUCT SPEC: 108-1329	SIZE: A1
2 PLC ±0.13	3 PLC ±0.13	APPLICATION SPEC: 114-16016	CAGE CODE: 776262
4 PLC ±0.13	ANGLES ±4°	WEIGHT: -	RESTRICTED TO: -
MATERIAL: -	FINISH: -	CUSTOMER DRAWING	SCALE: 2:1 SHEET 2 OF 2 REV: A5