

Note: All part numbers are RoHS Compliant.

10mm [.394] Pitch, 30A with Wire Protector—Series TSB500



Material & Finish

- Housing Material**—Polyamide 6
- Flammability**—UL94V-2
- Color**—Natural (off white)
- Tubular Contact**—Brass, tin plated
- Screw**—Steel, M3
- Screw Plating**—Zinc with chromate
- Wire Protector**—Stainless steel

Mechanical Properties

- Pitch (terminal spacing)**—10mm [.394]
- Wire Strip Length**—5mm [0.20"]
- Min. Wire Pull-Out Force**—75lbs.
- Recommended Tightening Torque**—5 in.-lbs.
- Recommended Screwdrivers**—Stanley 1016, Sears Craftsman 41429, Xcelite R184

Electrical Properties

- UL Maximum Current**—30A; 10-22 AWG
- CSA Maximum Current**—25A; 12-24 AWG
- Operating Voltage**—250V
- Dielectric Withstand**—3500V

Environmental Properties

- Continuous Working Temperature**—-35°C to +100°C [-31°F to +212°F]

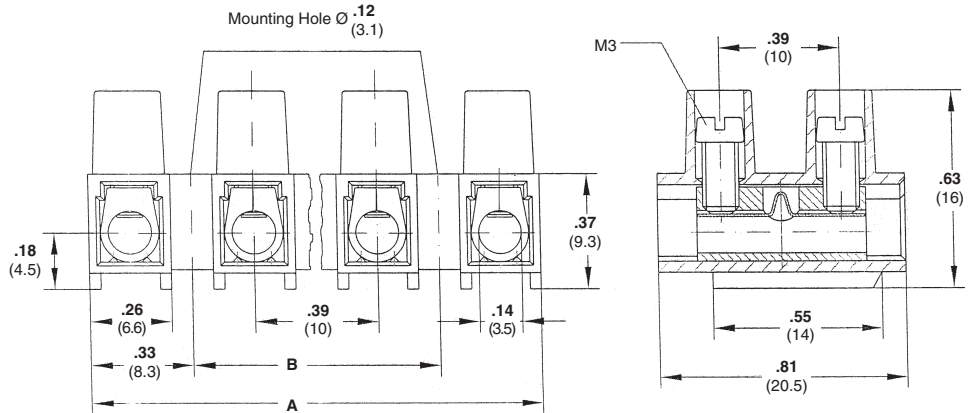

No. of Positions	Dimensions		Wire Protector	
	A	B	Part Number	Catalog Number
1	6.6 (.26)	—	1776296-1	TSB500 0131DS
2	16.6 (.65)	—	1776296-2	TSB500 0231DS
3	26.6 (1.05)	10 (.39)	1776296-3	TSB500 0331DS
4	36.6 (1.44)	20 (.79)	1776296-4	TSB500 0431DS
5	46.6 (1.83)	30 (1.18)	1776296-5	TSB500 0531DS
6	56.6 (2.23)	40 (1.57)	1776296-6	TSB500 0631DS
7	66.6 (2.62)	50 (1.97)	1776296-7	TSB500 0731DS
8	76.6 (3.02)	60 (2.36)	1776296-8	TSB500 0831DS
9	86.6 (3.41)	70 (2.76)	1776296-9	TSB500 0931DS
10	96.6 (3.80)	80 (3.15)	1-1776296-0	TSB500 1031DS
11	106.6 (4.20)	90 (3.54)	1-1776296-1	TSB500 1131DS
12	116.6 (4.59)	100 (3.94)	1-1776296-2	TSB500 1231DS

Europa Terminal Blocks
5

