

**NOTE**



All numerical values are in metric units [with U.S. customary units in brackets]. Dimensions are in millimeters [and inches]. Unless otherwise specified, dimensions have a tolerance of  $\pm 0.13$  [ $\pm .005$ ] and angles have a tolerance of  $\pm 2^\circ$ . Figures and illustrations are for identification only and are not drawn to scale.

**1. INTRODUCTION**

This specification covers the requirements for application of Mini-Universal MATE-N-LOK 2 Connectors for free-hanging and printed circuit (pc) board applications. These connectors provide a reliable and economical means of grouping multiple-lead connections in computers, computer/peripheral equipment, business machines, entertainment centers, and appliances. Mini-Universal MATE-N-LOK 2 Connectors are mateable with existing Mini-Universal MATE-N-LOK Connectors.

Housings are available in 2-, 3-, 4-, 6-, 8-, 9-, 10-, 12- (dual row and matrix), 14-, 15-, 16-, 18-, 20-, 22-, and 24- circuit positions for free-hanging applications. Vertical pc board pin headers are available in 2-, 3-, 4-, 6-, 8-, 9-, 10-, 12-, 14-, 15-, 16-, 18-, 20-, 22-, and 24-circuit configurations. Right-angle pc board pin headers are available in 2-, 3-, 4-, 6-, 8-, 10-, 12-, 14-, 16-, 18-, 20-, 22-, and 24-circuit configurations.

When corresponding with TE Connectivity (TE) Personnel, use the terminology provided on this specification to help facilitate your inquiry for information. Basic terms and features of components are provided in Figure 1.

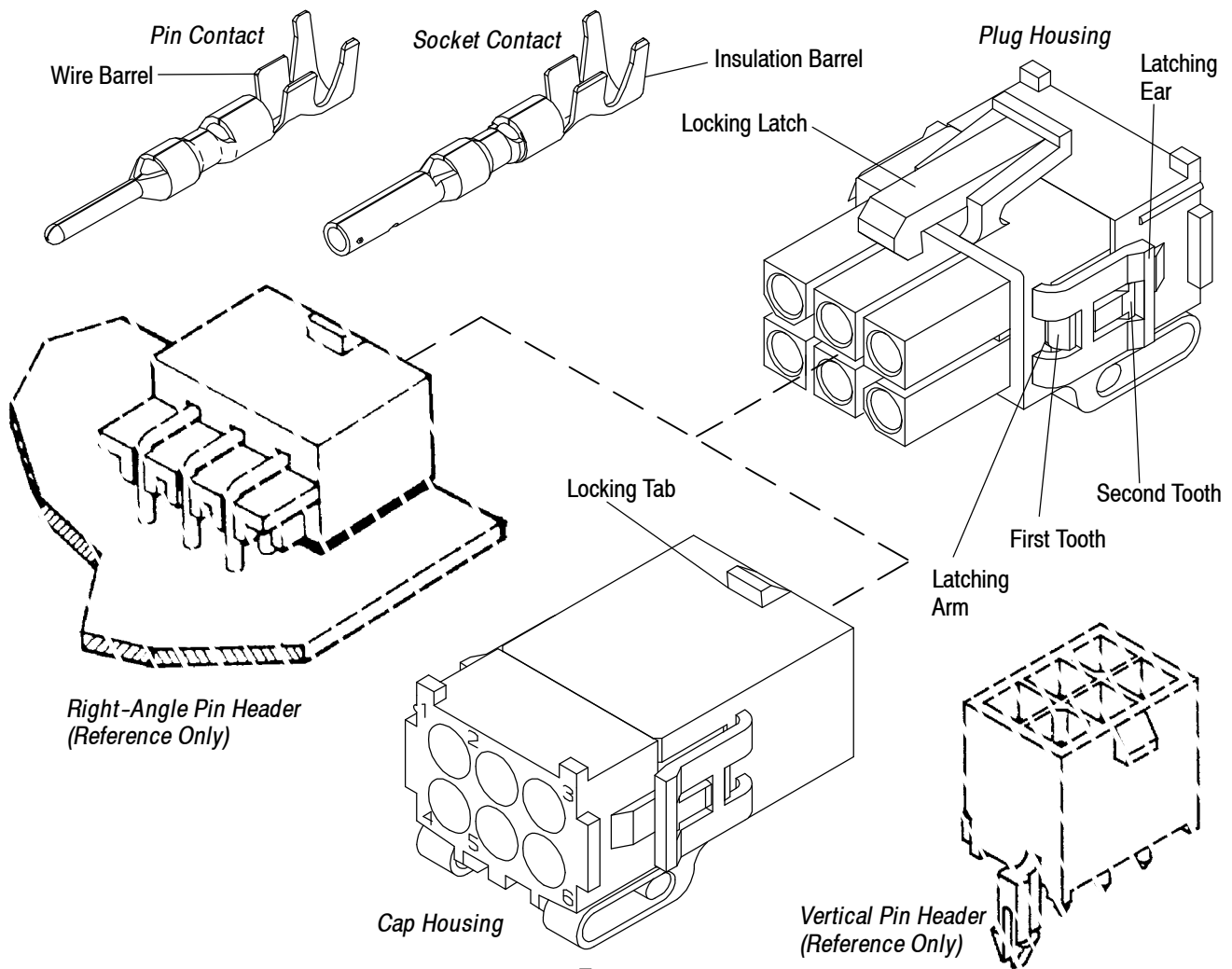

Figure 1

---

## 2. REFERENCE MATERIAL

### 2.1. Revision Summary

- Updated document to corporate requirements
- New logo

### 2.2. Customer Assistance

Reference Base Part Number 794220 and Product Code 0957 are representative numbers of Mini-Universal MATE-N-LOK 2 Connectors. Use of these numbers will identify the product line and expedite your inquiries through a service network established to help you obtain product and tooling information. Such information can be obtained through a local TE Representative or, after purchase, by calling the Tooling Assistance Center or the Product Information number at the bottom of page 1.

### 2.3. Drawings

Customer Drawings for specific products are available from the responsible TE Engineering Department via the service network. The information contained in the Customer Drawings takes priority if there is a conflict with this specification or with any other technical documentation supplied by TE.

### 2.4. Specifications

Product Specification 108-1693 provides performance tests for Mini-Universal MATE-N-LOK 2 Connectors. Product Specification 108-1694 provides performance tests for Mini-Universal MATE-N-LOK 2 Headers. Application Specification 114-16017 provides application instructions for Mini-Universal MATE-N-LOK Connectors and Headers.

### 2.5. Instructional Material

The following list includes instruction sheets (408-series) that provide assembly procedures for product, operation, maintenance and repair of tooling; and customer manuals (409-series) that provides setup, operation, and maintenance of machines.

<u>Document Number</u>	<u>Document Title</u>
408-3295	Preparing Reel of Contacts for Application Tooling
408-3393	Mini-Universal MATE-N-LOK 2 Connectors
408-4118	Extraction Tool 189727-1 for Mini-Universal MATE-N-LOK Contacts
408-4443	Straight Action Hand Crimping Tool 90717-2
408-4489	Straight Action Hand Crimping Tool 90707-2
408-7424	Checking Terminal Crimp Height or Gaging Die Closure
408-7984	Insertion Tool 455830-1
408-8040	Heavy Duty Miniature Quick-Change Applicators (Side-Feed)
408-8059	General Preventive Maintenance for Applicators
408-8547	CERTI-CRIMP* II Straight Action Hand Tools
408-9640	Crimp Quality Monitor Applicators for Side-Feed and End-Feed Applications
408-9816	Handling of Reeled Products
408-9930	PRO-CRIMPER* III Hand Crimping Tool Frame Assembly 354940-1
408-9965	PRO-CRIMPER III Hand Crimping Tool 90870-1
409-5128	AMP-O-LECTRIC* Model "K" Terminating Machine 565435-5
409-5842	AMP-O-LECTRIC Model "G" Terminating Machine 354500-[ ]
409-5852	AMPOMATOR* CLS III-G Lead Making Machine 122500-[ ]
409-5866	AMPOMATOR CLS IV Lead-Making Machine 217500-[ ]
409-5878	AMPOMATOR CLS IV Lead Making Machine 356500-[ ]
409-10012	AMP-O-MATIC* Side Feed Stripper-Crimper III Machine 1320895-[ ]
409-10016	Entry Level Terminator (ELT) Machine 1338600-[ ]
409-10027	Stripping Modules 1490500 and 1490502
409-10029	Stripping Modules 1490501 and 1490503

## 3. REQUIREMENTS

### 3.1. Storage

#### A. Ultraviolet Light

Prolonged exposure to ultraviolet light may deteriorate the chemical composition used in the contacts.

**B. Reeled Contacts**

When using reeled contacts, store coil wound reels horizontally and traverse wound reels vertically.

**C. Shelf Life**

The contacts should remain in the shipping containers until ready for use to prevent deformation to the contacts and/or damage to the housings. The contacts should be used on a first in, first out basis to avoid storage contamination that could adversely affect signal transmissions.

**D. Chemical Exposure**

Do not store contacts near any chemicals listed below, as they may cause stress corrosion cracking in the contacts.

Alkalies	Ammonia	Citrates	Phosphates	Citrates	Sulfur Compounds
Amines	Carbonates	Nitrites	Sulfur Nitrites		Tartrates



Where the above environmental conditions exist, phosphor-bronze contacts are recommended instead of brass if available.

**3.2. Wire Selection and Preparation**

Contacts are available for the wire sizes and insulation diameters specified in the table in Figure 2. Insulation shall be stripped for a length of 3.20 to 3.70 mm [.126 to .146 in.] for one-wire crimping and 3.50 to 3.90 mm [.138 to .157 in.] for two-wire crimping.

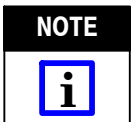

The applied crimp dimension (within the functional range of the product) is dependent on the termination tooling being used. Refer to the documentation (applicator logs and instruction sheets) supplied with the termination tooling for the applied crimp height. See Section 5, TOOLING.

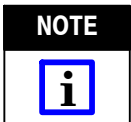

The wire strip length is approximately 0.79 mm [.031 in.] longer than the contact wire barrel. DO NOT nick, scrape, or cut the wire conductor during the stripping operation.

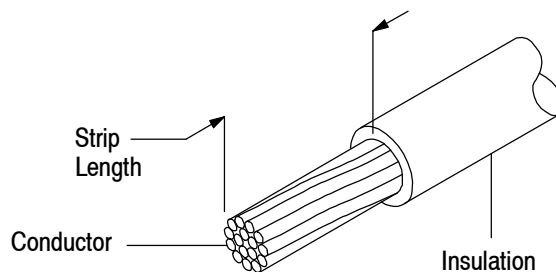

**AUTOMATIC MACHINE WIRE CRIMP DIMENSION**

WIRE (Stranded Only)		WIRE BARREL CRIMP		INSULATION BARREL CRIMP WIDTH (REF)
SIZE (AWG)	INSULATION DIAMETER	HEIGHT $\pm 0.05$ [.002]	WIDTH	
30	0.88-1.27 [.035-.050]	0.50 [.020]	1.06 [.042]	1.78 [.070]
28		0.55 [.022]		
26		0.60 [.024]		
26	1.20-1.75 [.047-.069]	0.63 [.025]●	1.22 [.048]	2.03 [.080]
24		0.69 [.027]		
22		0.78 [.031]		

● When crimping tin-coated 26 AWG wire (0.15 mm [.006 in.] dia., 7 strands) control crimp height to +0.03/-0.05 mm [+0.001/-0.002 in.].

Figure 2 (cont'd)

AUTOMATIC MACHINE WIRE CRIMP DIMENSION				
WIRE (Stranded Only)		WIRE BARREL CRIMP		INSULATION BARREL CRIMP WIDTH (REF)
SIZE (AWG)	INSULATION DIAMETER	HEIGHT $\pm 0.05$ [.002]	WIDTH	
22	1.49-2.39 [.059-.094]	0.91 [.036]	1.78 [.070]	2.79 [.110]
20		0.99 [.039]		
18		1.14 [.045]		
22 x (2)		0.99 [.039]		
20	2.0-3.20 [.079-.126]	1.07 [.042]	1.78 [.070]	3.30 [.130]
18		1.21 [.048]		
16		1.30 [.051]		
20 x (2)		1.30 [.051]		
HAND TOOL WIRE CRIMP DIMENSIONS				
WIRE (Stranded Only)		WIRE BARREL CRIMP		INSULATION BARREL CRIMP WIDTH (REF)
SIZE (AWG)	INSULATION DIAMETER	HEIGHT $\pm 0.05$ [.002]	WIDTH	
30	1.52 [.060] Max.	0.58 [.023]	1.07 [.042]	1.78 [.070]
28		0.58 [.023]		
26		0.64 [.025]		
26	1.20-1.75 [.047-.069]	0.69 [.027]	1.07 [.042]	2.03 [.080]
24		0.69 [.027]		
22		0.78 [.031]		
22	1.50-2.39 [.059-.094]	0.79 [.031]	1.58 [.062]	2.79 [.110]
20		0.79 [.031]		
18		1.04 [.041]		
22 x (2)	1.70 [.067] x (2) Max.	1.04 [.041]	1.78 [.070]	3.30 [.130]
20	2.00-3.20 [.079-.126]	1.07 [.042]		
18		1.07 [.042]		
20 x (2)	1.91 [.075] x (2) Max.	1.30 [.051]		
16	2.48-3.20 [.098-.126]	1.30 [.051]		

Figure 2 (end)

### 3.3. Contact Crimp Requirements

The contact must be crimped onto the wire according to instructions packaged with applicable tooling. After crimping, the contact should appear as shown in Figure 3. A typical pin contact is shown as it should appear after crimping; these requirements apply equally to the socket contact.



*The wire insulation must not be damaged during the crimping process.*

#### A. Wire Barrel Crimp

The crimp applied to the wire portion of the contact is the most compressed area and is most critical in ensuring optimum electrical and mechanical performance of the crimped contact. The contact wire barrel crimp height must be within the dimension provided in Figure 2.

#### B. Effective Crimp Length

For optimum crimp effectiveness, the crimp must be within the area shown in Figure 3 and must meet the crimp dimensions provided in Figure 2. Effective crimp length shall be defined as that portion of the wire barrel, excluding bellmouth(s), fully formed by the crimping tool. Instructions for adjusting, repairing, and inspecting tools are packaged with the tools. See Section 5, TOOLING.

#### C. Bellmouths

Front and rear bellmouths shall be evident and conform to the dimensions given in Figure 3.

**D. Cutoff Tabs**

The cutoff tab shall be cut to the dimensions shown in Figure 3.

**E. Burrs**

The cutoff burr shall not exceed the dimensions shown in Figure 3.

**F. Wire Barrel Flash**

The wire barrel flash shall not exceed the dimensions shown in Figure 3, Section X-X.

**G. Insulation Barrel Crimp**

The insulation barrel shall grip the insulation firmly. A slight cut in the insulation by the insulation barrel is permissible as this causes no problems in actual use. Insulation crimp shall comply to width and height provided in Figure 3.

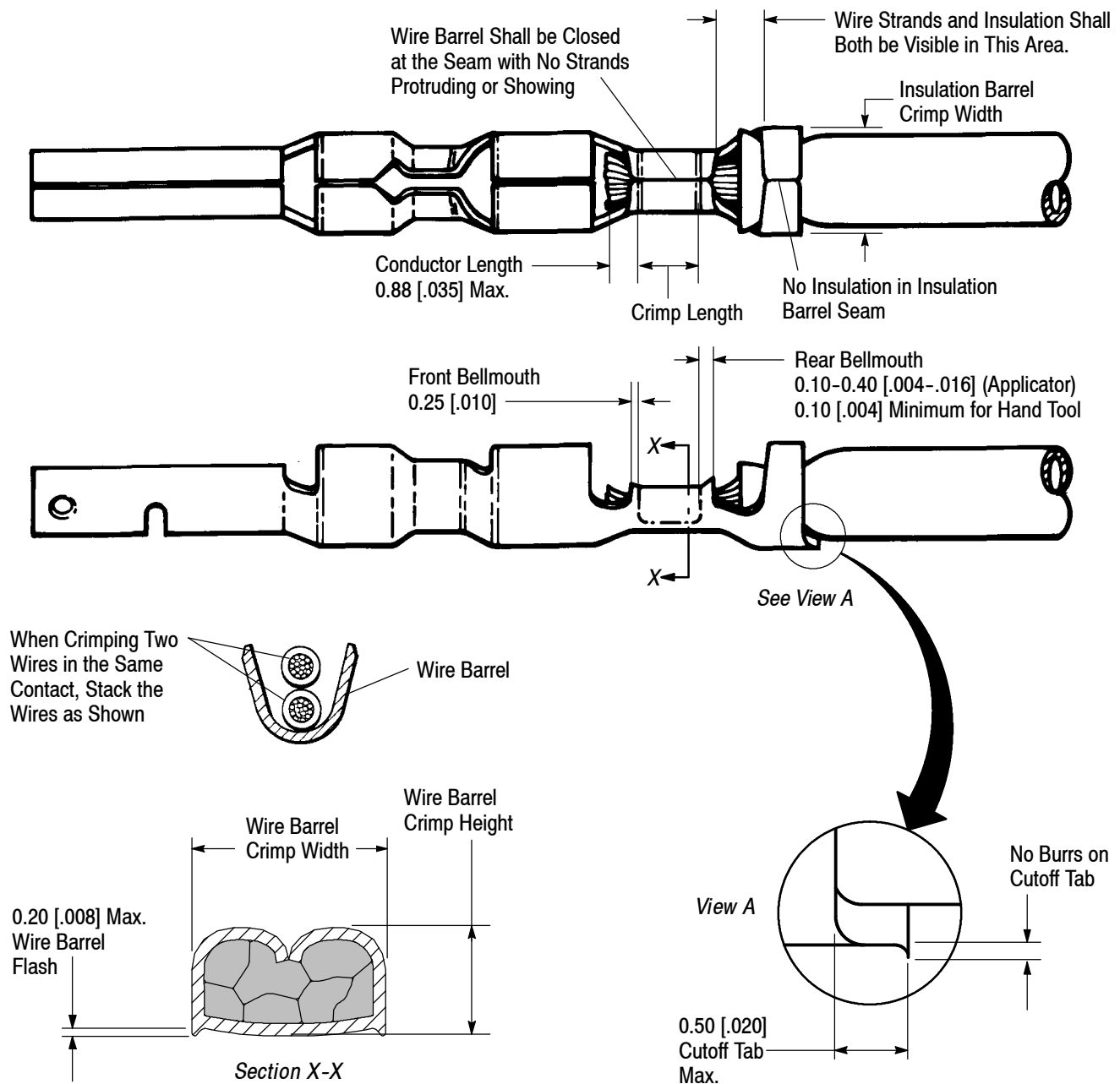

Figure 3

## H. Wire Location

The wire conductor and insulation must be visible in the transition area between the wire and insulation barrels.

## I. Conductor Extension

The conductor may extend beyond the wire barrel to the maximum shown.

## J. Wire Barrel Seam

The wire barrel seam must be closed with no evidence of loose wire strands visible in the seam.

1. The carrier cutoff tab length shall not exceed the dimensions given in Figure 3.
2. The wire barrel seam shall be closed adequately to confine all strands of the wire. There shall be no loose strands. Wire strands should not be embedded in the outside of the wire barrel.

## K. Straightness

The force applied during crimping may cause some bending between the crimped wire barrel and the mating portion of the contact. Such deformation is acceptable within the following limits, as shown in Figure 4.

*NOTE:* Angles are drawn for clarification only and are not to scale.

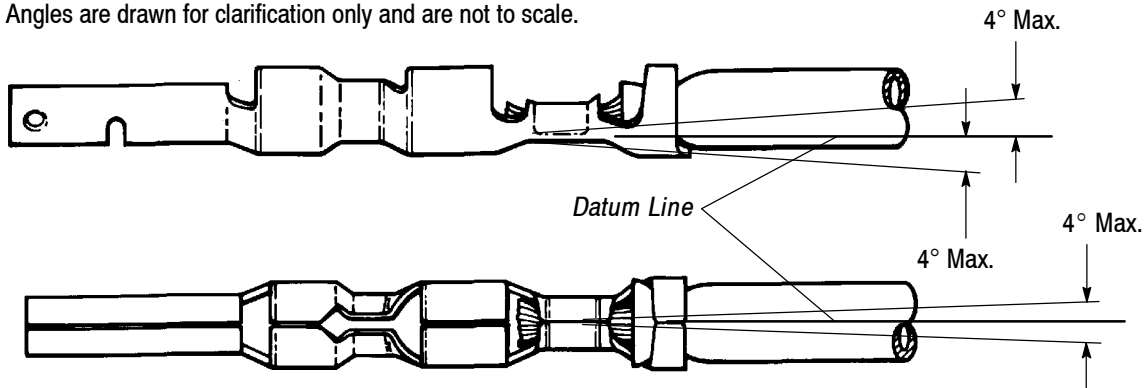

Figure 4

## L. Twist and Roll

There shall be no twist, roll, deformation or other damage to the mating portion of the crimped contact that will prevent proper mating. See Figure 5.

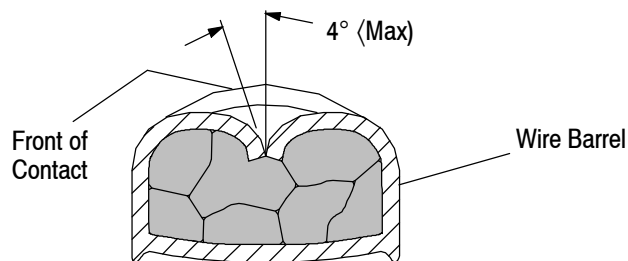

Figure 5

## 3.4. Assembly Procedures

1. Rotate (wire end) back side of connector housing 180° along the pivot track, until the first tooth of both latching arms engage; this is called the open position. See Figure 6.

**NOTE**

*The wire end of the housing must be in the open position before insertion of terminated contacts.*



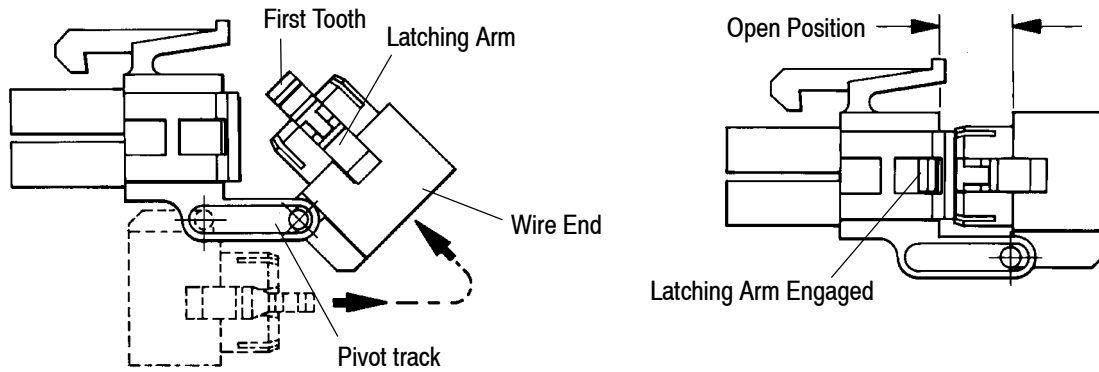

Figure 6

2. Select the appropriate contact cavities. Insert terminated pin or socket contacts into wire side of housing by grasping the wire directly behind the insulation barrel and pushing the contact with a twisting motion into the contact cavity until the contact stops and the housing cone fingers engage. See Figure 7.

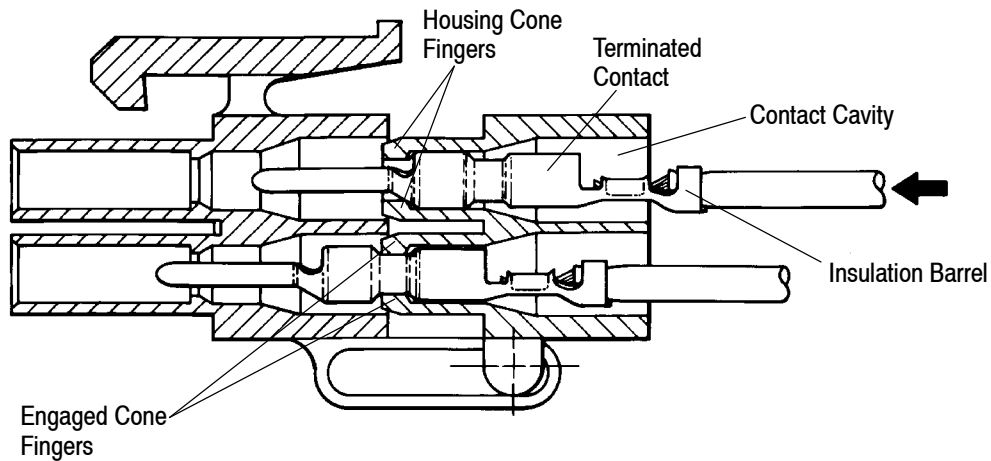

Figure 7

**NOTE**



Terminated pin and socket contacts are interchangeable between the plug and cap housing. This feature can be used as an additional polarization.

3. After all required contacts have been inserted, the wire end of the connector must be closed. To close the wire end of the connector housing, grasp the wire end and push forward until the second tooth of both latching arms engage as shown in Figure 8.

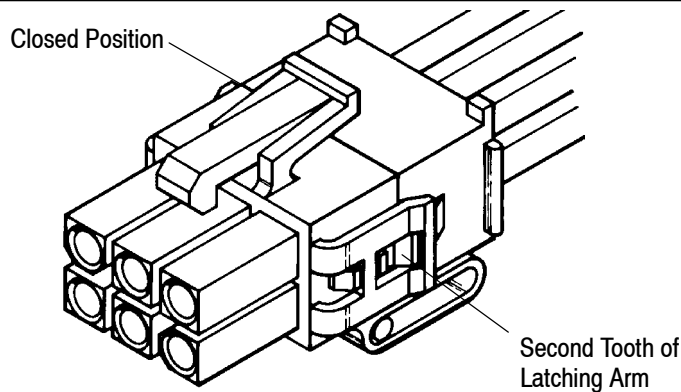

Figure 8

### 3.5. Disassembly Procedures.



To prevent damage to the connector assembly, the wire end must be in the open position before the removal of contacts.

1. Deflect latching ears one at a time, then lightly pull wire end of the plug assembly away from housing until the first tooth of the latching arms engage. See Figure 9.

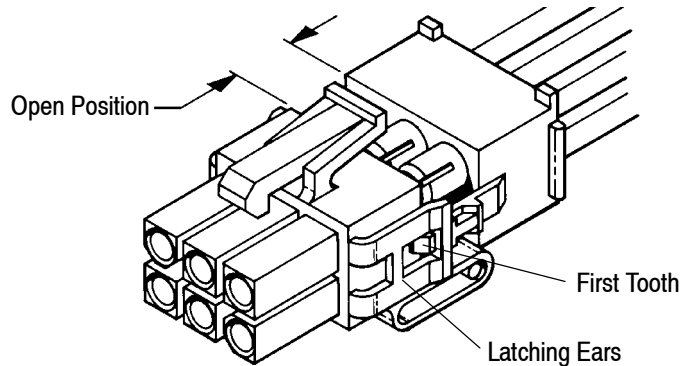

Figure 9

2. Grasp the selected wire by the insulation barrel and pull using a twisting motion, until terminated contact is free from housing as shown in Figure 10.
3. Follow step 2 for the remaining contacts.

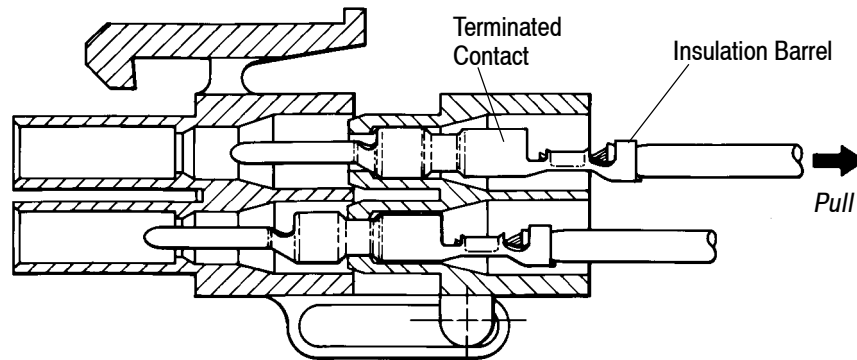

Figure 10

### 3.6. Polarization, Engagement, and Disengagement

#### A. Polarization

The housings are fully polarized (ribs and slots) to provide proper plug/cap mating using a positive locking mechanism to prevent accidental disengagement of mated connectors.

#### B. Engagement

The plug and cap must have an identical number of circuit positions. Polarizing features must be properly oriented. Insert cap connector straight toward plug connector until it bottoms and the locking latch engages the locking tab. The same technique can be used for the header-plug assembly.

#### C. Disengagement

For free hanging assemblies, depress locking latch on plug housing and pull straight out.

### 3.7. Repair/Replacement

Damaged crimped contacts or housings must be removed, discarded, and replaced with new components. Remove any damaged contacts by referring to the procedures given in Paragraph 3.5.



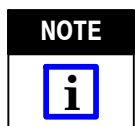

If a damaged contact is apparent before the contacts are inserted into the housing, cut the wire in back of the contact and reterminate the wire end. If contacts or housing are damaged after insertion, the wire must be cut directly in back of the housing and reterminated with new contacts and housing. See Section 5, TOOLING.

**4. QUALIFICATION**

Mini-Universal MATE-N-LOK 2 Connectors are Recognized by Underwriters Laboratories Inc. in File E28476, and Certified with CSA International in File LR7189.

**5. TOOLING**

Figure 11 provides tool part numbers and instructional material related to wire size.

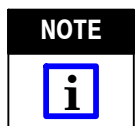

TE Tooling Engineers have designed machines for a variety of application requirements. For assistance in setting up prototype and production line equipment, contact TE Tool Engineering through your local TE Representative or call the Tooling Assistance Center number at the bottom of page 1.

- **Hand Crimping Tools**

Hand crimping tools that accommodate the full wire size range are designed for prototype and low-volume applications such as repair of damaged contacts.

- **Applicator**

Applicators are designed for the full wire size range of strip-fed, precision formed contacts, and provide for high volume, heavy duty, production requirements. The applicators can be used in bench or floor model power units.

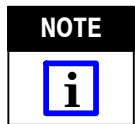

Each applicator is shipped with a metal identification tag attached. DO NOT remove this tag or disregard the information on it. Also, a packet of associated paperwork is included in each applicator shipment. This information should be read before using the applicator; then it should be stored in a clean, dry area near the applicator for future reference. Some changes may have to be made to the applicators to run in all related power units. Contact the Tooling Assistance Center number located at the bottom of page 1 for specific changes.

- **Power Units**

A power unit is an automatic or semi-automatic device used to assist in the application of a product. Power unit includes the power source used to supply the force or power to an applicator.

- **Insertion/Extraction Tooling**

Insertion Tools are designed for contacts crimped to small fragile wire. They are designed to stabilize the contact during insertion. For use of Insertion Tool 455830-1 which may be used with these contacts, refer to Instruction Sheet 408-7984. Extraction Tools are designed to release the locking lance inside the connector housing without damaging the housing or contacts. For use of Extraction Tool 189727-1 which may be used with these contacts, refer to Instruction Sheet 408-4118.

SIZE, AWG	INSULATION DIAMETER	APPLICATOR (408-8040)	POWER UNIT (DOCUMENT)	ANVIL LETTER	HAND TOOL (DOCUMENT)	INSERTION TOOL (408-7984)	EXTRACTION TOOL (408-4118)
30-26	0.88-1.27 [.035-.050]	567418-1	122500-2, -3 (409-5852)	---	90717-2 (408-4443)	455830-1	189727-1
			217500-1, -2 (409-5866)				
			356500-1, -2 (409-5878)				
		567418-2	354500-1 (409-5842)				
			565435-5 (409-5128)				
			1338600-3, -4 (409-10016)				
		567418-3	354500-1 (409-5842)				

Figure 11 (cont'd)

SIZE, AWG	INSULATION DIAMETER	APPLICATOR (408-8040)	POWER UNIT (DOCUMENT)	ANVIL LETTER	HAND TOOL (DOCUMENT)	INSERTION TOOL (408-7984)	EXTRACTION TOOL (408-4118)
26-22	1.20-1.75 [.047-.069]	466990-2▲	1320895-1, -3 (409-10012)	26-24 (A)  and  22 (B)	90758-1 (408-9938) or 91529-1 (408-8547)	455830-1	189727-1
		567066-3	122500-2, -3 (409-5852)				
			217500-1, -2 (409-5866)				
			356500-1, -2 (409-5878)				
26-22	1.20-1.75 [.047-.069]	567066-4	354500-1 (409-5842)	26-24 (A)  and  22 (B)	90758-1 (408-9938) or 91529-1 (408-8547)	455830-1	189727-1
			565435-5 (409-5128)				
			1338600-3, -4 (409-10016)				
		567066-5	354500-[] (409-5842)				
			1338600-[] (409-10016)				
			567829-1▲				
22†-18	1.50-2.39 [.059-.094]	680854-1	122500-2, -3 (409-5852)	22-20 (A)  and  18 & 22 x (2) (B)	90759-1 (408-9962) or 91522-1 (408-8547)	455830-1	189727-1
			217500-1, -2 (409-5866)				
			356500-1, -2 (409-5878)				
		680854-2	354500-1 (409-5842)				
			565435-5 (409-5128)				
			680854-3				
20‡-16	2.00-3.20 [.079-.126]	680582-1	122500-2, -3 (409-5852)	20-18 (A)  and  16 & 20 x (2) (B)	58707-1 (408-4503) or 90707-2 (408-4489) or 91594-1 (408-8547)	455830-1	189727-1
			217500-1, -2 (409-5866)				
			356500-1, -2 (409-5878)				
		680582-2	354500-1 (409-5842)				
			565435-5 (409-5128)				
			1338600-3, -4 (409-10016)				
		680582-3	354500-[] (409-5842)				
			1338600-[] (409-10016)				

†For wire size 22 x (2), insulation diameter 1.70 mm [.067 in.] is maximum. ‡For wire size 20 x (2), insulation diameter 1.91 mm [.075 in.] is maximum. ▲No documents listed.

Figure 11 (cont'd)

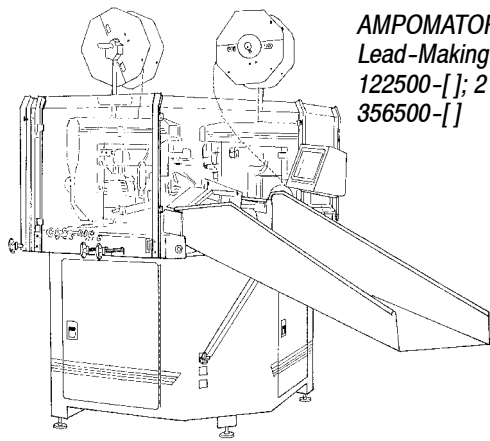

**AMPOMATOR CLS**  
Lead-Making Machines  
122500-[]; 217500-[];  
356500-[]

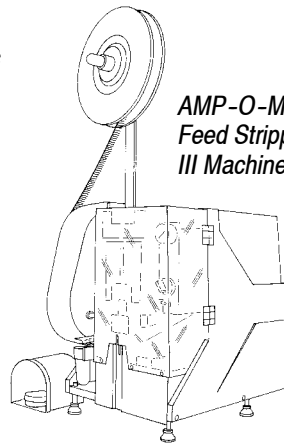

**AMP-O-MATIC Side**  
Feed Stripper-Crimper  
III Machine 1320895-[]

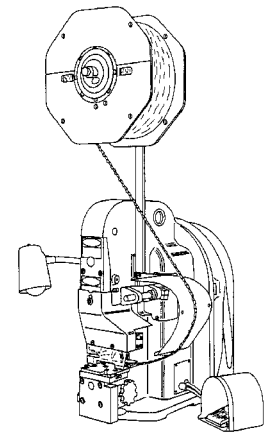

**AMP-O-LECTRIC Model "K"**  
Terminating Unit 565435-[]

*Typical Quick-Change  
Miniature Applicator*

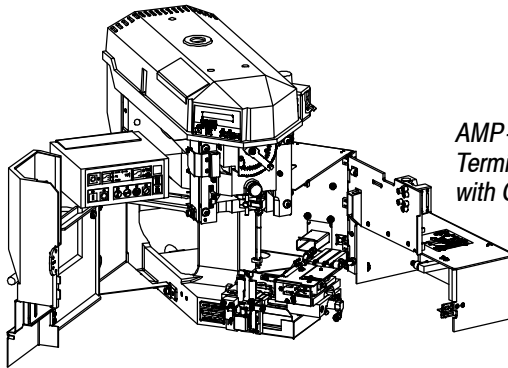
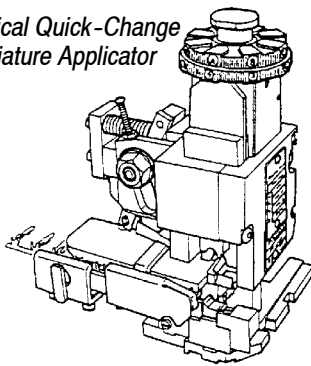

**AMP-O-LECTRIC Model "G"**  
Terminating Machine 354500-[]  
with Optional Stripping Module

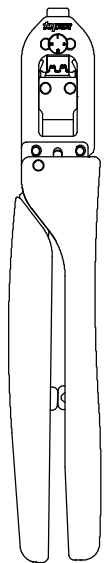

*Typical CERTI-CRIMP II*  
Straight Action Hand Tool

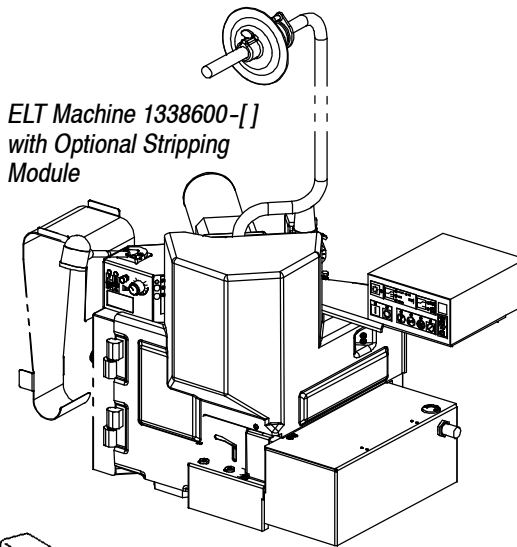

**ELT Machine 1338600-[]**  
with Optional Stripping  
Module

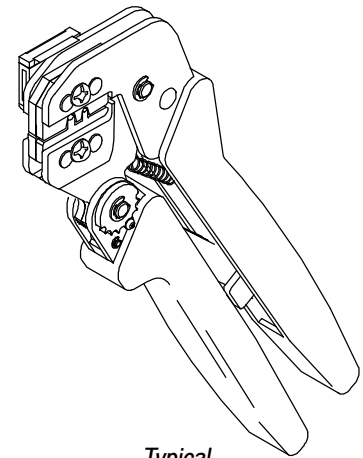

*Typical*  
**PRO-CRIMPER**  
Hand Tool

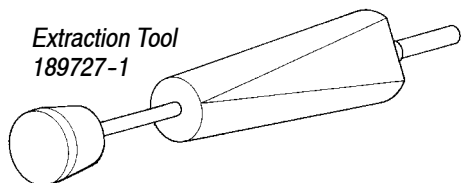

**Extraction Tool**  
189727-1

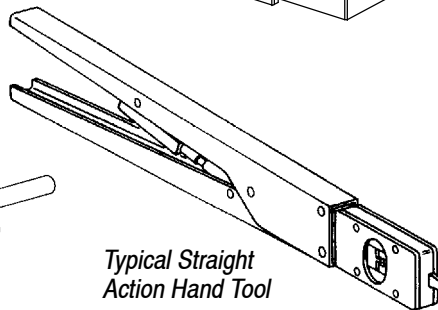

*Typical Straight*  
Action Hand Tool

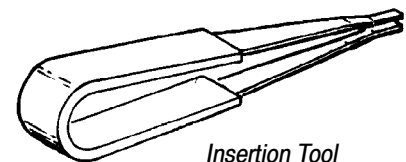

**Insertion Tool**  
455830-1

Figure 11 (end)

**6. VISUAL AID**

Figure 12 shows a typical application of Mini-Universal MATE-N-LOK 2 Connectors. This illustration should be used by production personnel to ensure a correctly applied product. Applications which DO NOT appear correct should be inspected using the information in the preceding pages of this specification and in the instructional material shipped with the product.

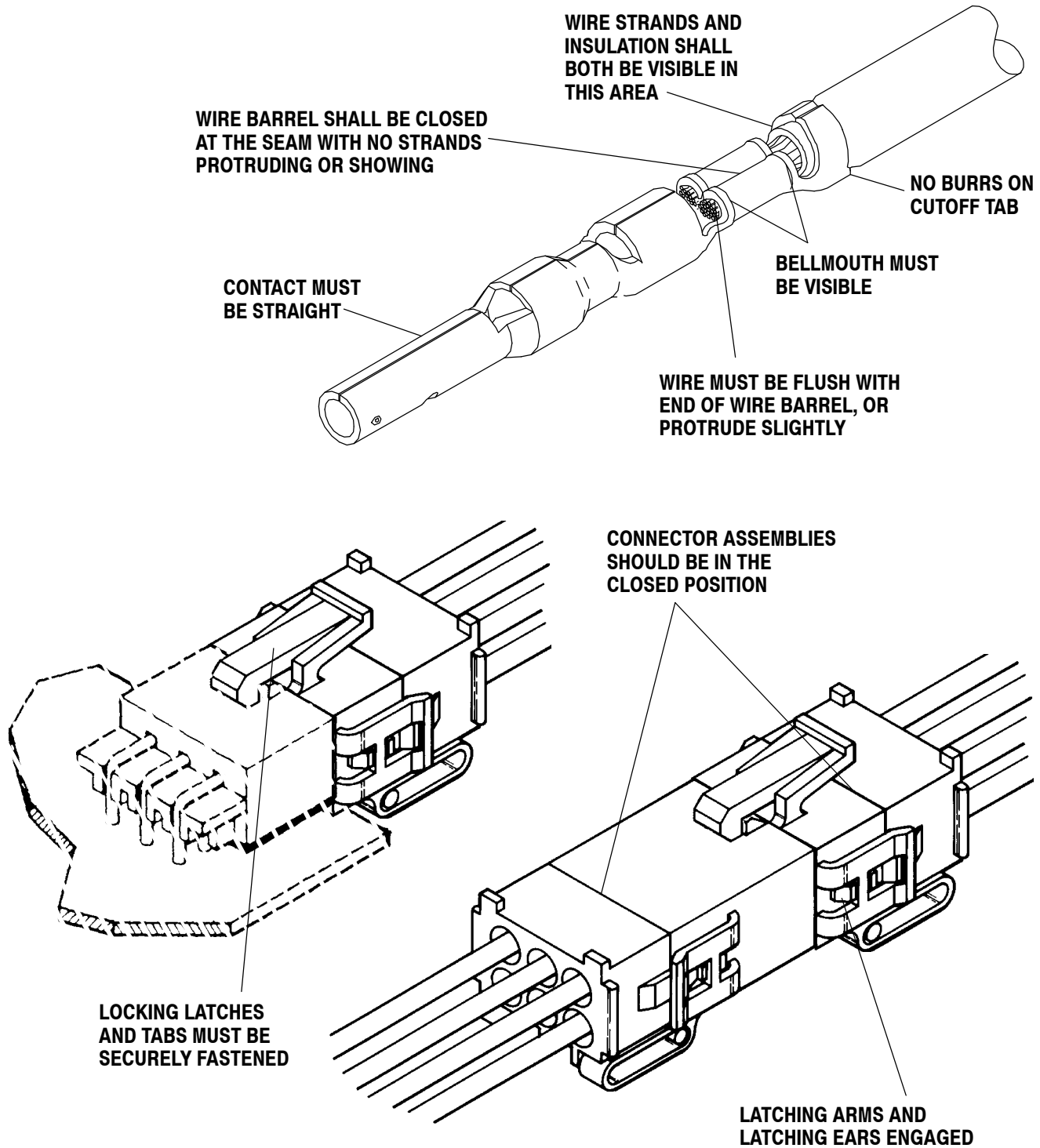

**FIGURE 12. VISUAL AID**