3 mm Micro MATE-N-LOK* Connector

1. SCOPE

1.1. Content

This specification covers performance, tests and quality requirements for the 3 mm Micro MATE-N-LOK* connector family. This connector family has wire-to-board and wire-to-wire configurations. The connectors are available in 2 to 24 positions in a double row configuration, and 2 to 12 positions in a single row configuration, with both configurations using 20 to 30 AWG wire.

1.2. Qualification

When tests are performed on the subject product line, procedures specified in Figure 1 shall be used. All inspections shall be performed using the applicable inspection plan and product drawing.

1.3. Qualification Test Results

Successful qualification testing on the subject product line was completed on 16Jan02. The Qualification Test Report number for this testing is 501-526. This documentation is on file at and available from Engineering Practices and Standards (EPS).

2. APPLICABLE DOCUMENTS

The following documents form a part of this specification to the extent specified herein. Unless otherwise specified, the latest edition of the document applies. In the event of conflict between the requirements of this specification and the product drawing, the product drawing shall take precedence. In the event of conflict between the requirements of this specification and the referenced documents, this specification shall take precedence.

2.1. TE Connectivity (TE) Documents

- 109 Series: Test Specifications as indicated in Figure 1
- 109-197: Test Specification (TE Test Specifications vs EIA and IEC Test Methods)
- 501-526: Qualification Test Report (3 mm Micro MATE-N-LOK* Connector)

2.2. Commercial Standard

EIA-364: Electrical Connector/Socket Test Procedures Including Environmental Classifications

3. REQUIREMENTS

3.1. Design and Construction

Product shall be of the design, construction and physical dimensions specified on the applicable product drawing.

3.2. Materials

Materials used in the construction of this product shall be as specified on the applicable product drawing.

3.3. Ratings

- Voltage: 250 volts AC or DC
- Current: See Figure 1 for applicable current carrying capability
- Temperature: -40 to 105°C

3.4. Performance and Test Description

Product is designed to meet the electrical, mechanical and environmental performance requirements specified in Figure 1. Unless otherwise specified, all tests shall be performed at ambient environmental conditions per EIA-364.

3.5. Test Requirements and Procedures Summary

Test Description	Requirement	Procedure															
Initial examination of product.	Meets requirements of product drawing.	EIA-364. Visual and dimensional (© of C) inspection per product drawing.															
Final examination of product.	Meets visual requirements.	EIA-364. Visual inspection.															
ELECTRICAL																	
Termination resistance.	20 milliohms maximum.	EIA-364-23. Subject specimens to 100 milliamperes maximum and 20 millivolts maximum open circuit voltage. See Figure 3.															
Insulation resistance.	1000 megohms initial. 100 megohms final.	EIA-364-21. Test between adjacent contacts of mated specimens.															
Dielectric withstanding voltage.	1 minute hold with no breakdown, flashover, or .5 milliampere maximum leakage.	EIA-364-20, Condition I. 1500 volts AC at sea level. Test between adjacent contacts of mated specimens.															
Temperature rise vs current.	30°C maximum temperature rise at specified current (100% energized). <table border="1" style="margin-left: auto; margin-right: auto;"> <thead> <tr> <th>Wire Size (AWG)</th> <th>Connector Position</th> <th>Amperes</th> </tr> </thead> <tbody> <tr> <td>20</td> <td>2 to 6</td> <td>5</td> </tr> <tr> <td>20</td> <td>8 to 24</td> <td>4.25</td> </tr> <tr> <td>28</td> <td>2 to 20</td> <td>2</td> </tr> <tr> <td>28</td> <td>22 to 24</td> <td>1.8</td> </tr> </tbody> </table>	Wire Size (AWG)	Connector Position	Amperes	20	2 to 6	5	20	8 to 24	4.25	28	2 to 20	2	28	22 to 24	1.8	EIA-364-70, Method 1. Stabilize at a single current level until 3 readings at 5 minute intervals are within 1°C.
Wire Size (AWG)	Connector Position	Amperes															
20	2 to 6	5															
20	8 to 24	4.25															
28	2 to 20	2															
28	22 to 24	1.8															

Figure 1 (continued)

Test Description	Requirement	Procedure														
MECHANICAL																
Solderability, dip test.	Solderable area shall have a minimum of 95% solder coverage.	EIA-364-52, Category 3 For thru-hole. EIA-638 for surface mount. Subject contacts to solderability.														
Crimp tensile.	<table border="1"> <thead> <tr> <th>Wire Size (AWG)</th> <th>Crimp Tensile (kg [lb] minimum)</th> </tr> </thead> <tbody> <tr> <td>20</td> <td>7.95 [17.5]</td> </tr> <tr> <td>22</td> <td>5.00 [11]</td> </tr> <tr> <td>24</td> <td>3.60 [7.9]</td> </tr> <tr> <td>26</td> <td>2.05 [4.5]</td> </tr> <tr> <td>28</td> <td>1.40 [3.1]</td> </tr> <tr> <td>30</td> <td>0.77 [1.7]</td> </tr> </tbody> </table>	Wire Size (AWG)	Crimp Tensile (kg [lb] minimum)	20	7.95 [17.5]	22	5.00 [11]	24	3.60 [7.9]	26	2.05 [4.5]	28	1.40 [3.1]	30	0.77 [1.7]	EIA-364-8. Determine crimp tensile at a maximum rate of 25 ± 6 mm [$.98 \pm .24$ in] per minute.
Wire Size (AWG)	Crimp Tensile (kg [lb] minimum)															
20	7.95 [17.5]															
22	5.00 [11]															
24	3.60 [7.9]															
26	2.05 [4.5]															
28	1.40 [3.1]															
30	0.77 [1.7]															
Vibration, random.	No discontinuities of 1 microsecond or longer duration. See Note.	EIA-364-28, Test Condition VII, Condition D. Subject mated specimens to 3.10 G's rms between 20-500 Hz. 15 minutes in each of 3 mutually perpendicular planes. See Figure 4.														
Mechanical shock.	No discontinuities of 1 microsecond or longer duration. See Note.	EIA-364-27, Method A. Subject mated specimens to 50 G's half-sine shock pulses of 11 milliseconds duration. 3 shocks in each direction applied along 3 mutually perpendicular planes, 18 total shocks. See Figure 4.														
Durability.	See Note.	EIA-364-9. Mate and unmate specimens for 30 cycles for tin plated specimens, 75 cycles for 15 μ m gold plated specimens, and 150 cycles for 30 μ m gold plated specimens at a maximum rate of 500 cycles per hour.														
Header contact retention.	Contact shall not dislodge. See Note.	EIA-364-29. Apply an axial load of 1.4 kg [3.1 lb] to contacts at a rate of 0.45 kg [1 lb] per second and hold for 6 seconds.														
Crimp contact retention.	Contact shall not dislodge. See Note.	EIA-364-29. Apply an axial load of 1.81 kg [4 lb] to contacts at a rate of 0.45 kg [1 lb] per second and hold for 6 seconds.														

Figure 1 (continued)

Test Description	Requirement	Procedure
Crimp contact insertion force.	0.7 kg [1.5 lb] maximum. See Note.	TE Spec 109-41. Measure force necessary to insert crimped contacts into housing.
Mating force (contacts only).	0.7 kg [1.5 lb] maximum per contact.	EIA-364-13. Measure axial force necessary to mate specimens without locking latches at a maximum rate of 5.08 mm [.2 in] per minute.
Unmating force (contacts only).	0.07 kg [0.15 lb] minimum per contact.	EIA-364-13. Measure axial force necessary to unmate specimens without locking latches at a maximum rate of 12.7 mm [.5 in] per minute.
Housing lock strength.	2.7 kg [6 lb] minimum.	EIA-364-98. Determine housing lock strength at a maximum rate of 12.7 mm [.5 in] per minute.
ENVIRONMENTAL		
Thermal shock.	See Note.	EIA-364-32, Test Condition VIII. Subject specimens to 5 cycles between -40 and 105°C.
Humidity/temperature cycling.	See Note.	EIA-364-31, Method III. Subject specimens to 10 cycles (10 days) between 25 and 65°C at 80 to 100% RH.
Temperature life.	See Note.	EIA-364-17, Method A, Test Condition 4, Test Time Condition C. Subject mated specimens to 105°C for 500 hours.
Mixed flowing gas.	See Note.	EIA-364-65, Class IIA. Subject mated specimens to environmental Class IIA for 20 days.

NOTE

Shall meet visual requirements, show no physical damage, and meet requirements of additional tests as specified in the Product Qualification and Requalification Test Sequence shown in Figure 2.

Figure 1 (end)

3.6. Product Qualification and Requalification Test Sequence

Test or Examination	Test Group (a)				
	1	2	3	4	5
	Test Sequence (b)				
Initial examination of product	1	1	1	1	1
Termination resistance	3,7	2,6			
Insulation resistance			3,7		
Dielectric withstanding voltage			4,8		
Temperature rise vs current		3,7			
Solderability, dip test				2	
Crimp tensile					2
Vibration, random	5				
Mechanical shock	6				
Durability	4				
Header contact retention			10(c)		
Crimp contact retention			11		
Crimp contact insertion force			2		
Mating force (contacts only)	2				
Unmating force (contacts only)	8				
Housing lock strength			9		
Thermal shock			5		
Humidity/temperature cycling		4(d)	6		
Temperature life		5			
Mixed flowing gas		4(d)			
Final examination of product	9	8	12	3	3

- NOTE**
- (a) See paragraph 4.1.A.
 - (b) Numbers indicate sequence in which tests are performed.
 - (c) Test omitted when testing wire-to-wire connectors.
 - (d) The fourth test in this sequence will be either humidity/temperature cycling for tin plated specimens or mixed flowing gas for gold plated specimens. Precondition specimens with 10 cycles of durability.

Figure 2

4. QUALITY ASSURANCE PROVISIONS

4.1. Qualification Testing

A. Specimen Selection

Specimens shall be prepared in accordance with applicable Instruction Sheets and shall be selected at random from current production. All test groups shall each consist of a minimum of 5 specimens.

B. Test Sequence

Qualification inspection shall be verified by testing specimens as specified in Figure 2.

4.2. Requalification Testing

If changes significantly affecting form, fit or function are made to the product or manufacturing process, product assurance shall coordinate requalification testing, consisting of all or part of the original testing sequence as determined by development/product, quality and reliability engineering.

4.3. Acceptance

Acceptance is based on verification that the product meets the requirements of Figure 1. Failures attributed to equipment, test setup or operator deficiencies shall not disqualify the product. If product failure occurs, corrective action shall be taken and specimens resubmitted for qualification. Testing to confirm corrective action is required before resubmittal.

4.4. Quality Conformance Inspection

The applicable quality inspection plan shall specify the sampling acceptable quality level to be used. Dimensional and functional requirements shall be in accordance with the applicable product drawing and this specification.

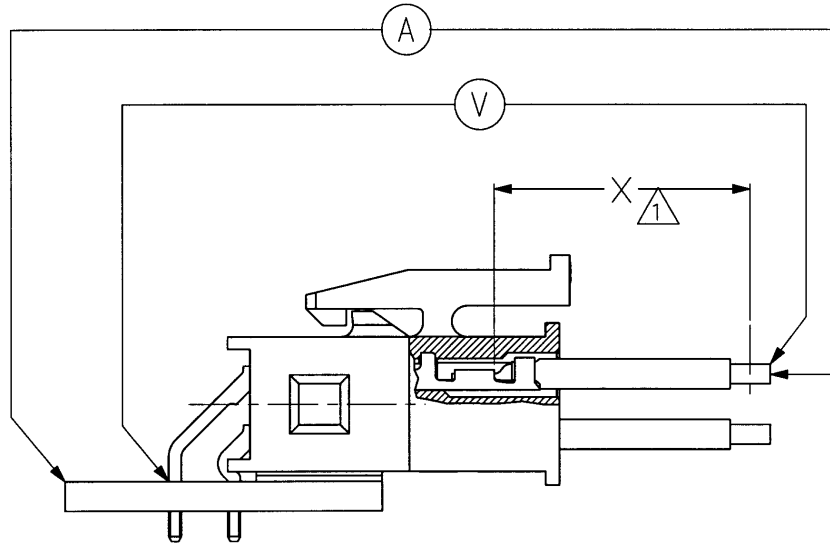

NOTE Resistance due to X length of wire is to be removed from all readings.

Figure 3
Termination Resistance Measurement Points

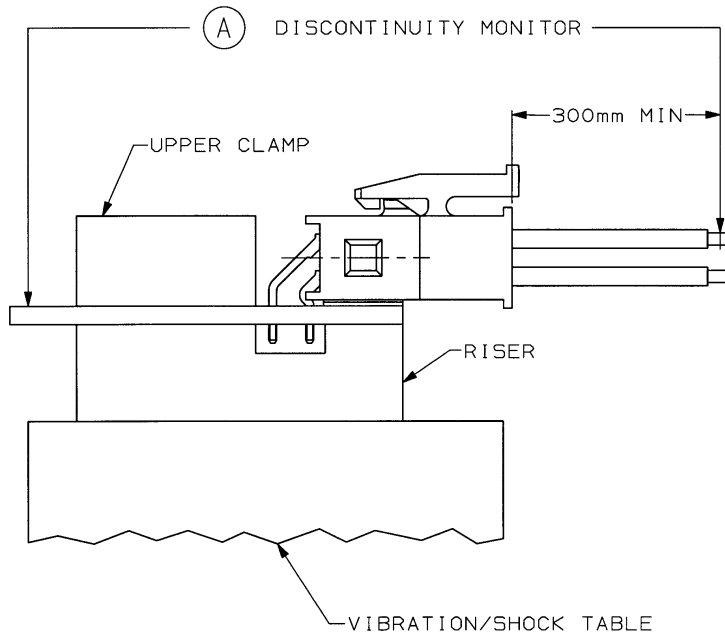

Figure 4
Vibration & Mechanical Shock Mounting Fixture