



Have a Question?
Chat with a Product Information Specialist

What can we help you find?

[Products](#) [Industries](#) [Resources](#) [About TE](#) [My Account](#) [Innovation](#) [Support Center](#)

1838891-2 Product Details

[Share](#) [Print](#) [Email](#)



1838891-2

TE Internal Number: 1838891-2

Active

[View 3D PDF](#)

M8/M12 Connector System

Always EU RoHS/ELV Compliant (Statement of Compliance)

Product Highlights:

- Connector
- Receptacle
- Not Field Serviceable
- 4 Positions
- Connector Color = Black

[View all Features](#)

Quick Links

- ▶ [Pricing & Availability](#)
- ▶ [Search for Tooling](#)
- ▶ [Product Feature Selector](#)
- ▶ [Contact Us About This Product](#)

[Add to My Part List](#) [Request Sample](#) [Find Similar Products](#) [Buy Product](#)

Documentation & Additional Information

Product Drawings:

- [M12 METAL FEMALE PANEL MOUNT CONNECTOR, SOLDER, STRA... \(PDF, English\)](#)

Catalog Pages/Data Sheets:

- None Available

Product Specifications:

- None Available

Application Specifications:

- None Available

Instruction Sheets:

- None Available

CAD Files: [\(CAD Format & Compression Information\)](#)

- [2D Drawing \(DXF, Version C\)](#)
- [3D Model \(IGES, Version C\)](#)
- [3D Model \(STEP, Version C\)](#)

[List all Documents](#)

Additional Information:

- [Product Line Information](#)

Related Products:

- [Tooling](#)

Product Features (Please use the Product Drawing for all design activity)

Product Type Features:

- [Product Type](#) = Connector
- Connector Type = Receptacle
- Thread Size = M12
- [LED](#) = Without

Mechanical Attachment:

- Mount = Panel

Body Features:

- Connector Color = Black
- Mount Style = Rear Mount

Configuration Features:

- [Number of Positions](#) = 4

Industry Standards:

- [RoHS/ELV Compliance](#) = RoHS compliant, ELV compliant
- [Lead Free Solder Processes](#) = Wave solder capable to 240°C, Wave solder capable to 260°C, Wave solder capable to 265°C
- [RoHS/ELV Compliance History](#) = Always was RoHS compliant

Conditions for Usage:

- Field Serviceable = No

Operation/Application:

- Application = Sensors

Packaging Features:

- Packaging Quantity = 50

Other:

- Brand = TE Connectivity

Corporate Information

- [About TE](#)
- [Investors](#)
- [News Room](#)
- [Supplier Portal](#)
- [Careers](#)
- [Terms & Conditions](#)
- [Privacy Policy](#)

Quick Links

- [Distributor Inventory](#)
- [Product Cross Reference](#)
- [Documents & Drawings](#)
- [Product Compliance Support Center](#)
- [Site Map](#)

Customer Support

- [Email or Chat With Us](#)
- [Find a Phone Number](#)
- [Knowledge Base](#)
- [Manage Your Account](#)

Keep Me Informed

THIS DRAWING IS UNPUBLISHED.

RELEASED FOR PUBLICATION

© COPYRIGHT - By -

ALL RIGHTS RESERVED.

LOC	DIST	REVISIONS					
E	B	P	LTR	DESCRIPTION	DATE	DWN	APVD
		C1		REVISED PER ECO-11-005150	21MAR11	RK	HMR

NOTES:

- ELECTRICAL DATA: CONTACT RESISTANCE: 10 mOhm MAX
INSULATION RESISTANCE: 100 MOhm MIN at 500VDC
CURRENT RATING: 5 AMPS (FOR 3, 4 AND 5 POSITIONS) AND 2 AMPS (FOR 8 POSITION ONLY)
BREAKDOWN VOLTAGE: 500 VAC MIN PER MINUTE
- ENVIRONMENTAL: OPERATING TEMPERATURE: -25°C TO +90°C
SEALING REQUIREMENTS: IP67
- PROD SPEC: 108-3641
- PACKAGING: 107-3334
- FOR TECHNICAL DATA REFER TO YOUR LOCAL TE CONNECTIVITY SALES OFFICE.
- ALL DIMENSIONS ARE NOMINAL FOR REFERENCE ONLY UNLESS OTHERWISE STATED.

ITEM	DESCRIPTION	MATERIAL	FINISH/COLOUR	QUANTITY / ITEM			
				-1	-2	-3	-4
1	CONNECTOR HOUSING	GF NYLON	BLACK	1	1	1	1
2	SOCKET CONTACT	BRASS	0.15µm GOLD OVER NICKEL	3	4	5	8
3	CONNECTOR BODY	ZINC DIE CAST	2.5µm NICKEL PLATED	1	1	1	1
4	'O' RING	VITON	GREEN	1	1	1	1
5	'O' RING	EPDM	BLACK	1	1	1	1
6	SCREW NUT	ZINC DIE CAST	2.5µm NICKEL PLATED	1	1	1	1

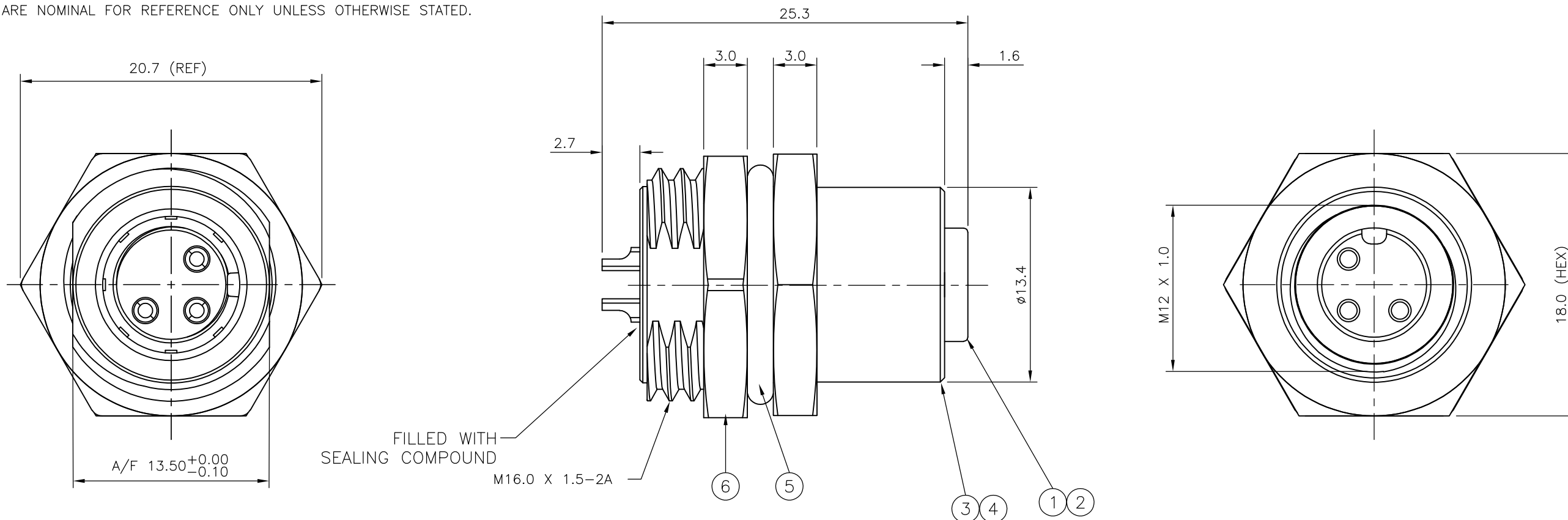

DESCRIPTION	NO. OF POS	PART NUMBER
M12 METAL FEMALE PANEL MOUNT CONNECTOR, SOLDER, STRAIGHT, REAR (HEXAGONAL) MOUNTING	8	1838891-4
M12 METAL FEMALE PANEL MOUNT CONNECTOR, SOLDER, STRAIGHT, REAR (HEXAGONAL) MOUNTING	5	1838891-3
M12 METAL FEMALE PANEL MOUNT CONNECTOR, SOLDER, STRAIGHT, REAR (HEXAGONAL) MOUNTING	4	1838891-2
M12 METAL FEMALE PANEL MOUNT CONNECTOR, SOLDER, STRAIGHT, REAR (HEXAGONAL) MOUNTING	3	1838891-1

THIS DRAWING IS A CONTROLLED DOCUMENT.		DWN A.Morey 22FEB06	STE TE Connectivity	
DIMENSIONS: mm		CHK F.Wheeler-King 01MAR07		
TOLERANCES UNLESS OTHERWISE SPECIFIED:		APVD F.Wheeler-King 01MAR07	NAME M12 METAL FEMALE PANEL MOUNT CONNECTOR, SOLDER, STRAIGHT, REAR (HEXAGONAL) MOUNTING	
0 PLC ± -		PRODUCT SPEC	SIZE	
1 PLC ± -		APPLICATION SPEC	CAGE CODE	
2 PLC ± -		WEIGHT	DRAWING NO	
3 PLC ± -			RESTRICTED TO	
4 PLC ± -			A3 00779 C-1838891	
ANGLES ± -			SCALE	
FINISH			SHEET	
MATERIAL			1 OF 2	
			REV	
			C1	

THIS DRAWING IS UNPUBLISHED. RELEASED FOR PUBLICATION
 © COPYRIGHT - By - ALL RIGHTS RESERVED.

LOC	DIST	REVISIONS			
P	LTR	DESCRIPTION	DATE	DWN	APVD
		SEE SHEET 1	-	-	-

1838891-1

1838891-2

1838891-3

1838891-4

PIN ASSIGNMENTS
FRONT VIEW

PIN ASSIGNMENTS
FRONT VIEW

PIN ASSIGNMENTS
FRONT VIEW

PIN ASSIGNMENTS
FRONT VIEW

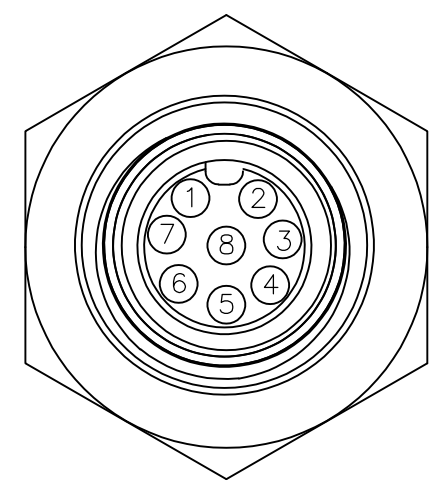
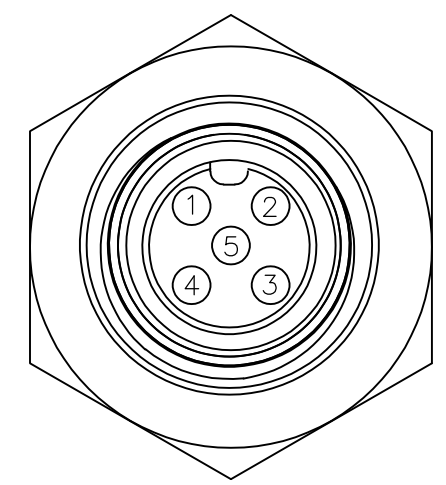
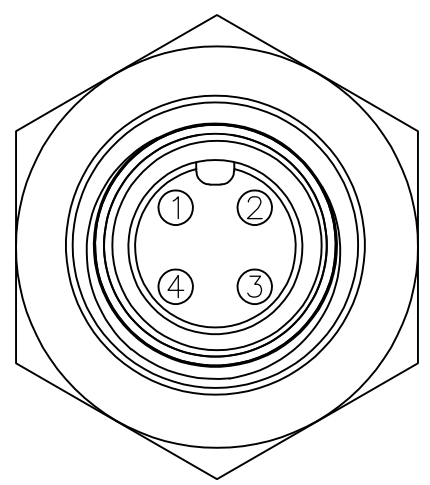
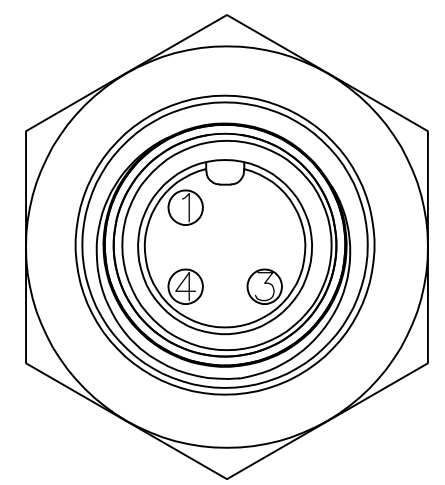

RECOMMENDED PANEL CUT-OUT
(MAX PANEL THICKNESS 4.5mm)

RECOMMENDED PANEL CUT-OUT
(MAX PANEL THICKNESS 4.5mm)

RECOMMENDED PANEL CUT-OUT
(MAX PANEL THICKNESS 4.5mm)

RECOMMENDED PANEL CUT-OUT
(MAX PANEL THICKNESS 4.5mm)

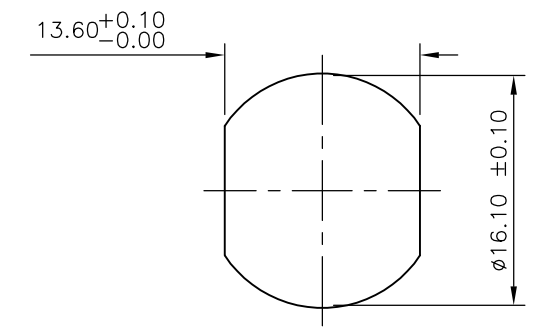
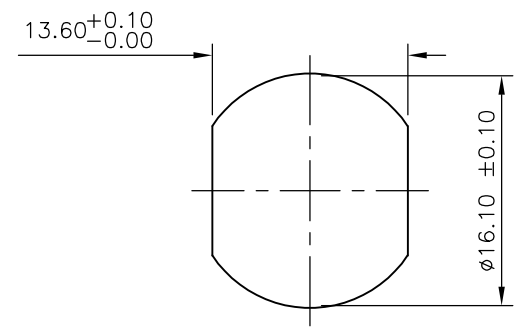
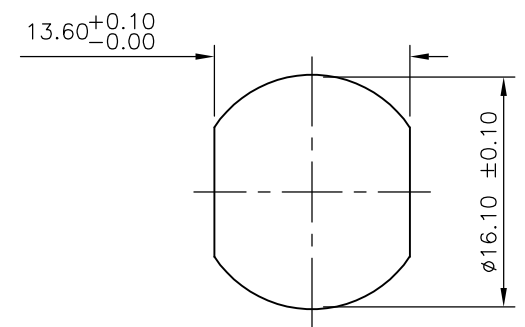
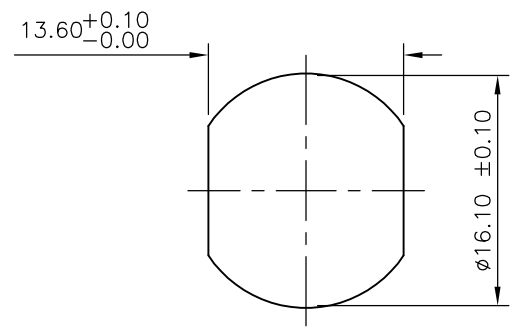

THIS DRAWING IS A CONTROLLED DOCUMENT.

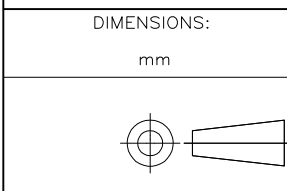

DIMENSIONS:	TOLERANCES UNLESS OTHERWISE SPECIFIED:
mm	
0 PLC	± -
1 PLC	± -
2 PLC	± -
3 PLC	± -
4 PLC	± -
ANGLES	± -
FINISH	-

MATERIAL -

DWN	A. Morey	28FEB07
CHK	F. Wheeler-King	01MAR07
APVD	F. Wheeler-King	01MAR07
PRODUCT SPEC	-	-
APPLICATION SPEC	-	-
WEIGHT	-	-



NAME: M12 METAL FEMALE PANEL MOUNT CONNECTOR, SOLDER, STRAIGHT, REAR (CIRCULAR) MOUNTING

SIZE	CAGE CODE	DRAWING NO	RESTRICTED TO
A3	00779	C-1838891	-

CUSTOMER DRAWING SCALE NTS SHEET 2 OF 2 REV C1