

LOC		DIST		REVISIONS			
P	LTR	DESCRIPTION	DATE	DRN	APVD		
E		SEE PCN EGA0-1080-04-03	06MAY2004	MD	TK		
F		SEE PCN EGA0-1860-04-01	17AUG2004	PK	TK		
F1		CONTACT CHART MODIFIED	25JUL2005	SC	MP		
F2		SEE E-05-009128	13OCT2005	MP	TK		

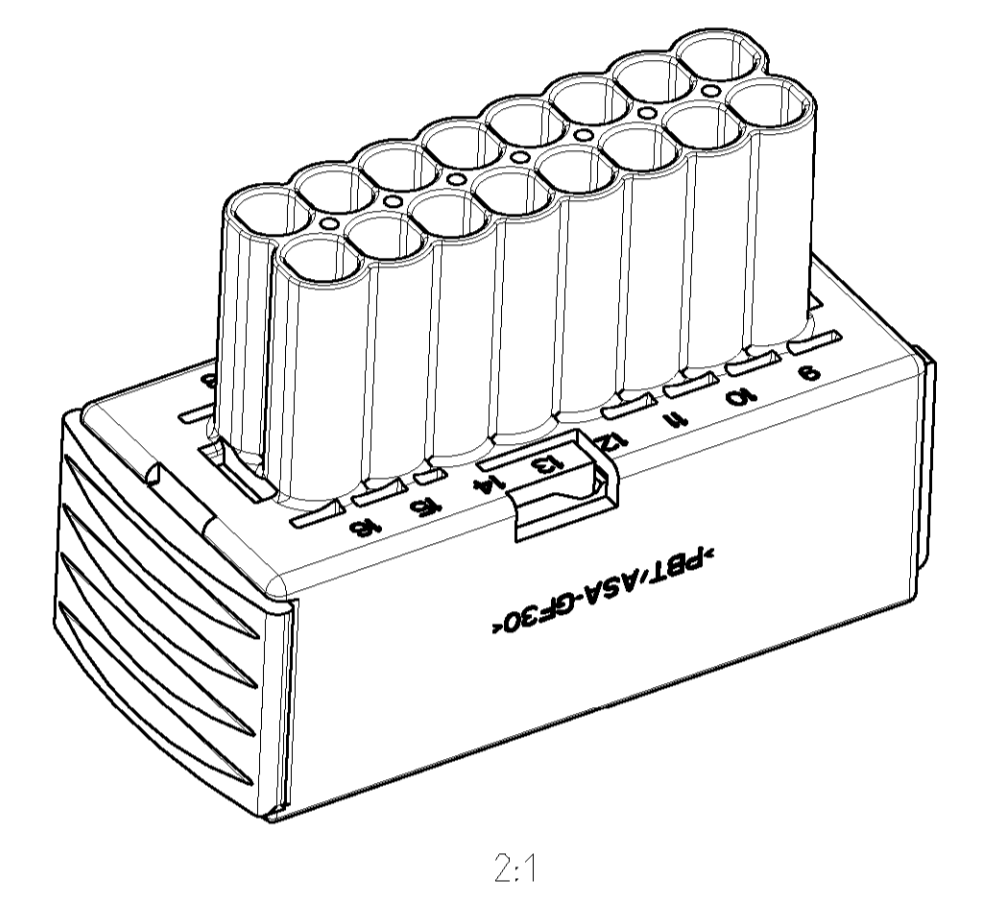

NOTES :

- 1 Au-VERSION OF CONTACT IS 1-xxxxxx-1
Au-Version des Kontaktes ist 1-xxxxxx-1
- F1 2 WATER TIGHTNESS ACC. GMI 12590; 5.10.3
FURTHER INFORMATIONS SEE PRODUCT SPECIFICATION 108-18102-1/...-9
Wasserdichtheit nach GMI 12590, 5.10.3
Weitere Informationen siehe Produktspezifikation 108-18102-1/...-9
- 3 Einfall bis auf 23.5mm zulässig
SHRINKAGE UP TO 23.5MM ALLOWED

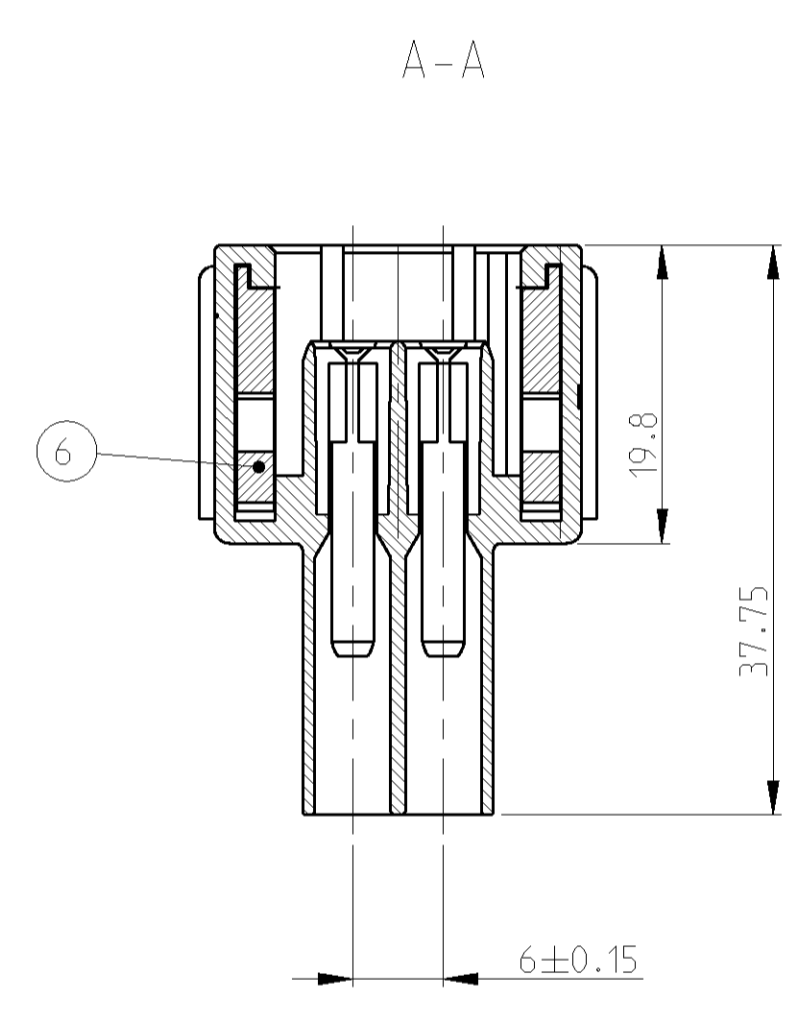
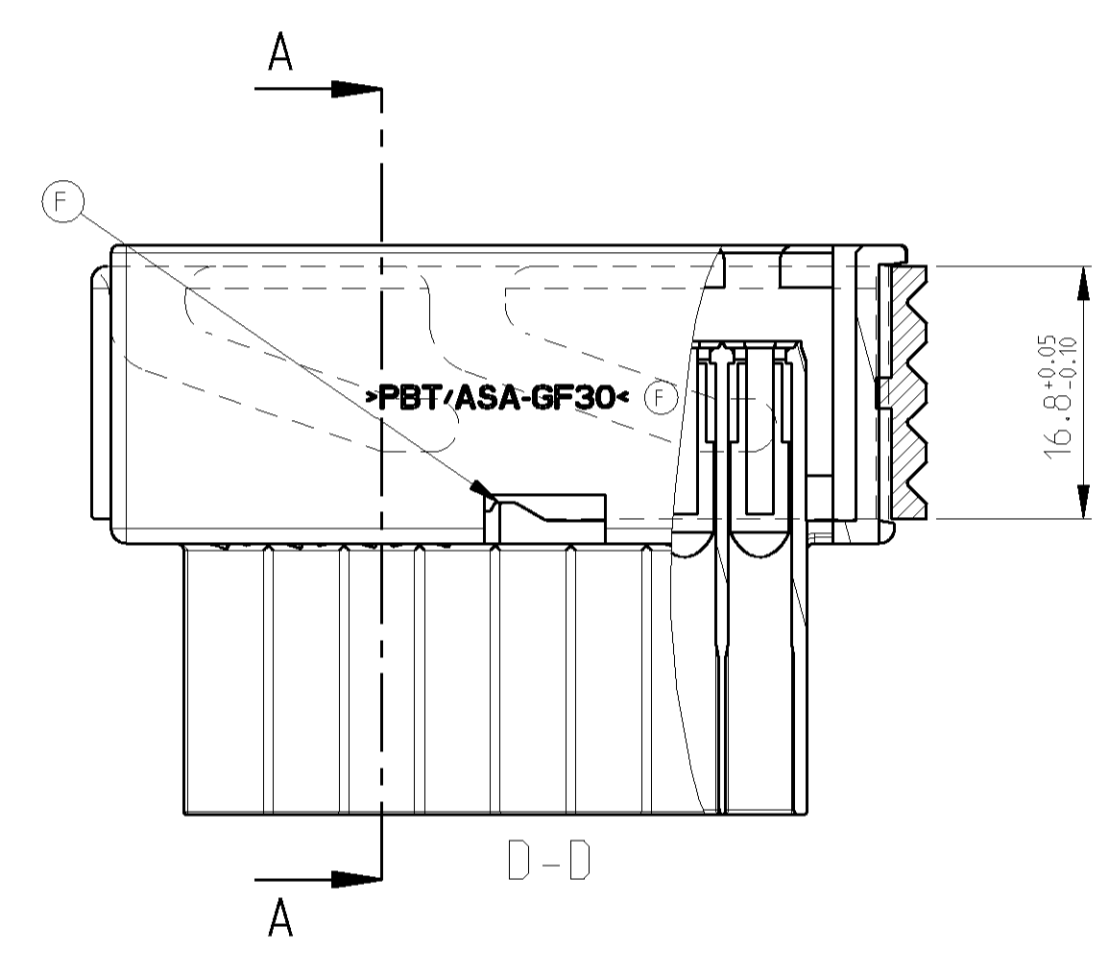
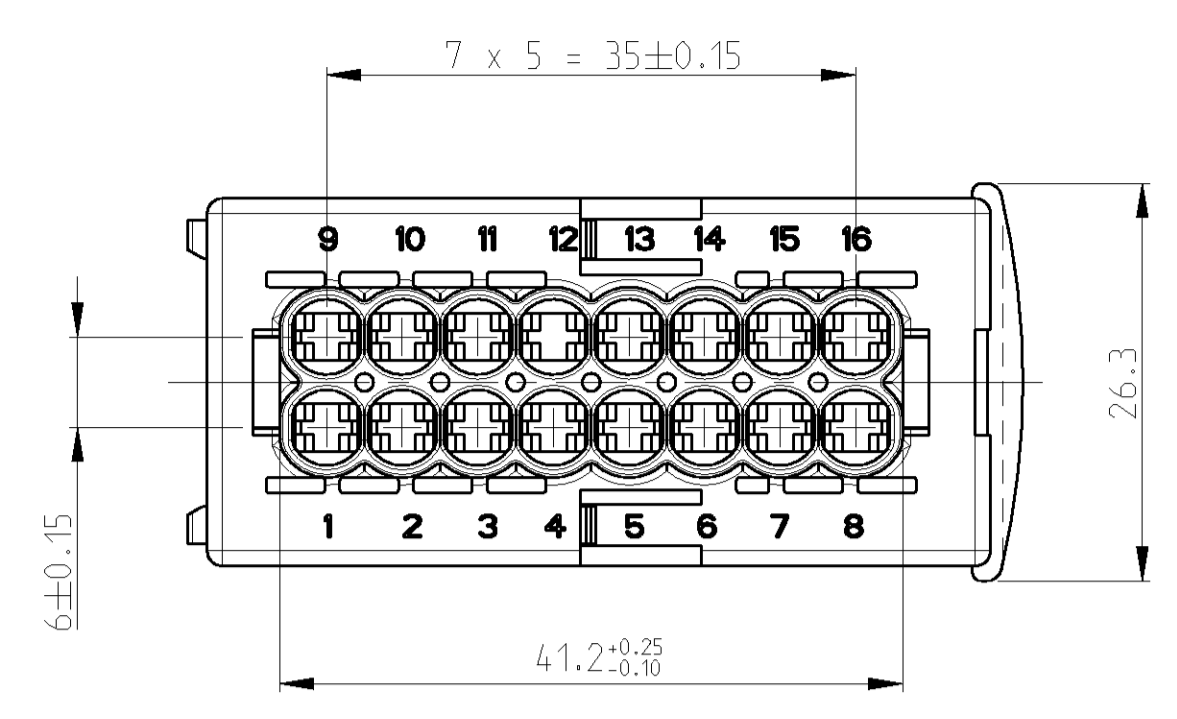
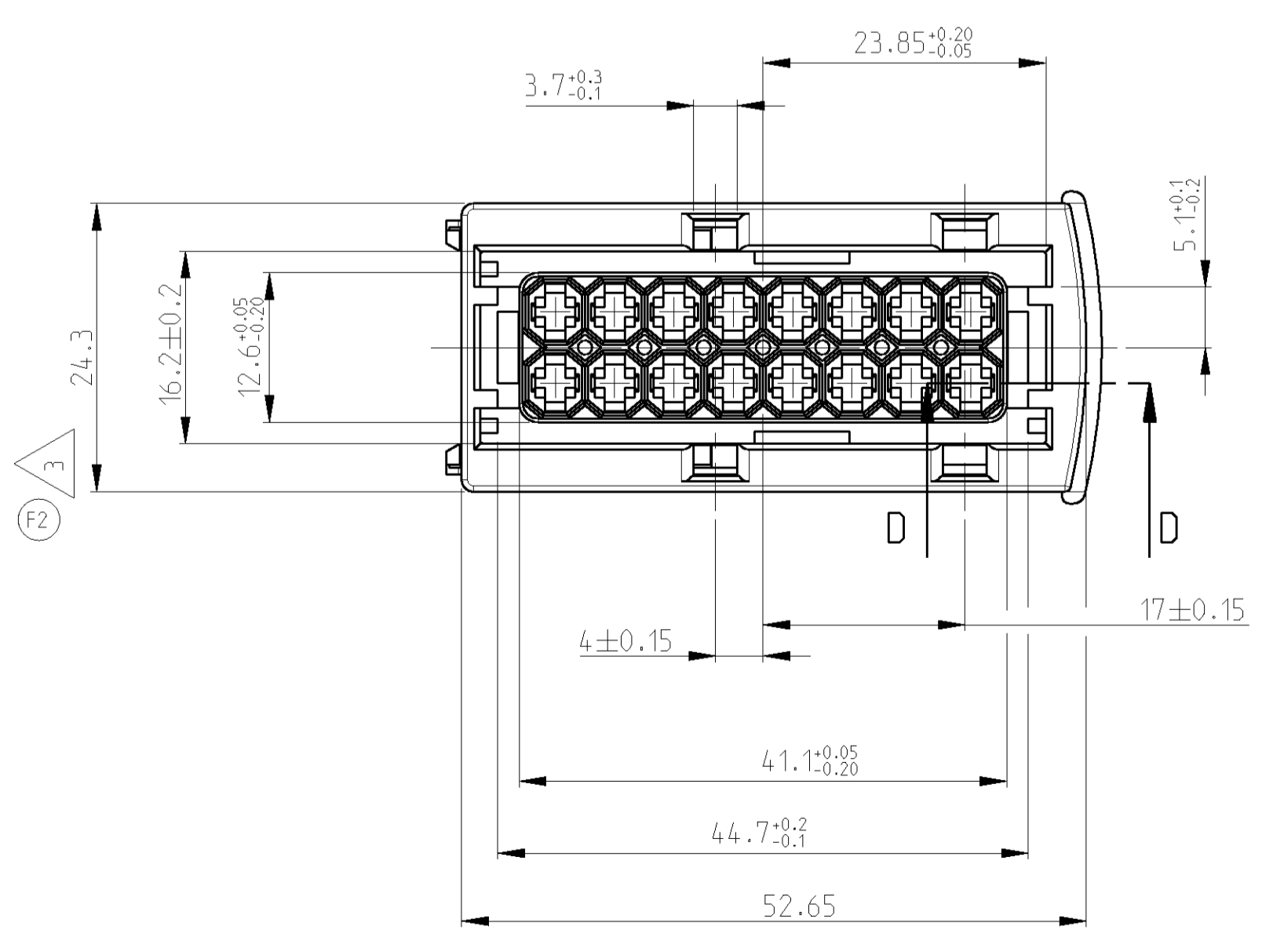

JPT	ORDER-NO.	WIRE SIZE [mm ²]	MATERIAL	FINISH	SINGLE WIRE SEAL	COLOR	WATER-TIGHTNESS
JPT	0-0929937-1	1.5 - 2.5	CuFe 2	TINNED	0-0828905-1	WHITE	IPX 9K
JPT	0-0929939-1	0.75 - 1.0	CuFe 2	TINNED	0-0828904-1	LIGHT BLUE	IPX 9K
JPT	0-0929939-1	0.5	CuFe 2	TINNED	0-0963294-1	BLUE	IPX 9K
JPT	0-0929941-1	0.35	CuFe 2	TINNED	0-0963294-1	BLUE	IPX 9K

MATED WITH	AMP PART NO.	REV.	PCS	MATERIAL	COLOR	DESCRIPTION	ITEM NO.
-	-	-	-	-	-	-	-
-	-	-	-	-	-	-	-
-	-	-	-	-	-	-	-
-	-	-	-	-	-	-	-
1-964449-1	1-967242-1	F	1	PBT/ASA-GF30	RED	SLIDE	2
	CODING A1		1	PBT/ASA-GF30	BLACK	JPT HSG., 16POS.	1

DIMENSIONS: mm		TOLERANCES UNLESS OTHERWISE SPECIFIED:		DWG: S. GARCIA 27-SEP-1993		tyco Electronics		Tyco Electronics AMP GmbH	
0 PLC ±		0.3		ENR: A. MACHILL 27-SEP-1993		APVD: -		0-64625 Bensheim	
1 PLC ±		0.3		NAME: -		PRODUCT SPEC: 108-18102		JPT Rec.-HOUSING, 16POS., ASSY	
2 PLC ±		0.3		APPLICATION SPEC: 114-18175		WEIGHT: -		JPT Bu.-Gehäuse, 16pol., Assy	
3 PLC ±		0.3		MATERIAL: -		FINISH: -		SIZE: CAGE CODE: DRAWING NO: RESTRICTED TO	
4 PLC ±		0.3		CUSTOMER DRAWING		SCALE: 2:1		SHEET 1 OF 1 REV: F2	