

201047-2 Product Details



201047-2

TE Internal Number: 201047-2



M Series Connectors

 Always EU RoHS/ELV Compliant (Statement of Compliance)

Product Highlights:

- Product Series = M Series
- Hardware
- Hardware Type = Guide Socket Kit
- Guide Pin/Socket Type = Corner
- Thread Size = 6-32

Documentation & Additional Information

Product Drawings:

- [GUIDE SOCKET KIT, UNASSEMBLED RECTANGULAR, MINIATURE...](#) (PDF, English)

Catalog Pages/Data Sheets:

- [M_SERIES_PIN_AND_SOCKET_CONNECTORS](#) (PDF, English)

Product Specifications:

- None Available

Application Specifications:

- None Available

Instruction Sheets:

- [Corner Guide and Center Guide Pin and socket Kits Fo...](#) (PDF, English)
- [AMP* 29 POSITION \(MIXED\) SERIES M CONNECTOR](#) (PDF, English)

CAD Files: (CAD Format & Compression Information)

- [2D Drawing](#) (DXF, Version W)
- [3D Model](#) (IGES, Version W)
- [3D Model](#) (STEP, Version W)

Additional Information:

- [Product Line Information](#)

Related Products:

- [Tooling](#)

Product Features (Please use the Product Drawing for all design activity)

Product Type Features:

- Product Series = M Series
- [Product Type](#) = Hardware
- Thread Size = 6-32
- Strain Relief = Without
- Sealed = No

Mechanical Attachment:

- Hardware Type = Guide Socket Kit
- [Mounting Hardware](#) = Nuts and Lockwashers

Dimensions:

- Length (X-Axis) (mm [in]) = 20.19 [0.795]
- Width (Z-Axis) (mm [in]) = 6.48 [0.255]
- Profile Height (Y-Axis) (mm [in]) = 7.35 [0.289]

Body Features:

- Guide Pin/Socket Type = Corner
- Mating Retention = Without

Housing Features:

- Mating Alignment = Without

Industry Standards:

- [RoHS/ELV Compliance](#) = RoHS compliant, ELV compliant
- [Lead Free Solder Processes](#) = Not relevant for lead free process
- RoHS/ELV Compliance History = Always was RoHS compliant

Conditions for Usage:

- For Use With = 28 Position High Voltage Connectors, 75, 104 and 160 Cf Position Standard Connectors, 75, 104 and 160 Cf Position Posted Connectors, 29 Position Mixed Connectors, 12 Position High Current Connectors

Packaging Features:

- Packaging Method = Bag
- Packaging Quantity = 100

Other:

- Brand = AMP
- Comment = Hardware supplied unassembled.

THIS DRAWING IS UNPUBLISHED. RELEASED FOR PUBLICATION ,19 .
 © COPYRIGHT 19 BY AMP INCORPORATED. ALL RIGHTS RESERVED.

LOC	DIST	REVISIONS			
P	LTR	DESCRIPTION	DATE	DWN	APVD
BD	36	W	REDRAWN PER EC 0020-1178-94	14 JUL 95	-

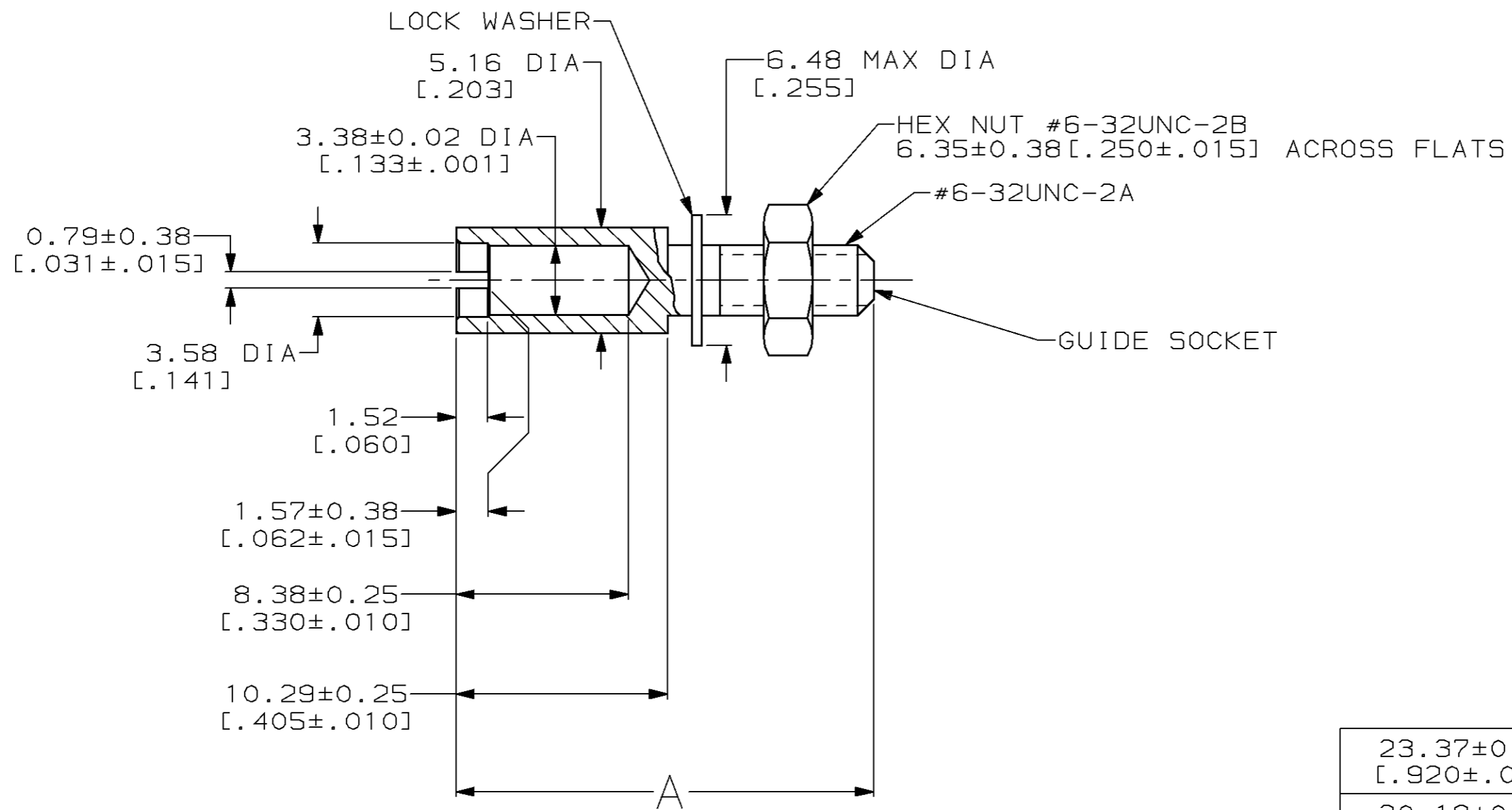

ASSEMBLED VIEW

23.37±0.25 [.920±.010]	201047-7
20.19±0.25 [.795±.010]	201047-2
A	PART NUMBER

- ① GUIDE SOCKET: STAINLESS STEEL.
LOCK WASHER: STAINLESS STEEL.
HEX NUT: CRS.
- ② HEX NUT: ZINC PLATED.

DIMENSIONS:		TOLERANCES UNLESS OTHERWISE SPECIFIED:		DWN		AMP Incorporated	
mm [INCHES]				CHK	DATE	NAME	Harrisburg, PA 17105-3608
		0 PLC	±-	C. REIFSNYDER	14 JUL 95	GUIDE SOCKET KIT, UNASSEMBLED RECTANGULAR, MINIATURE, CORNER, COMPLETE, M SERIES	DRAWING NO C-201047
		1 PLC	±-	R. STONE	17 JUL 95		
		2 PLC	±0.13 [.005]	G. STEINHAEUER	20 SEP 95		
		3 PLC	±-	PRODUCT SPEC		SIZE	CAGE CODE
		4 PLC	±-	APPLICATION SPEC		A3	00779
		ANGLES	±-	WEIGHT		SCALE 4:1	
MATERIAL ①	FINISH ②	CUSTOMER DRAWING		SHEET 1 OF 1		REV W	