

REVISIONS				
P	LTR	DESCRIPTION	DATE	DWN APD
T		REVISED PER ECO-13-016365	19OCT2013	KH MZ
U		REVISED PER ECO-19-011232	07AUG2019	RS MZ

- 1 HOUSING: NYLON, BLACK.
PERIPHERAL SEAL: ELASTOMER, BLACK.
THREADED INSERTS: BRASS.
- 2 CAVITY IDENTIFICATION ON FRONT AND REAR FACE.
- 3 WILL ACCEPT (16) MULTIMATE PIN CONTACTS.
- 4 HOUSING: NYLON, BLUE.
PERIPHERAL SEAL: ELASTOMER, BLACK.
THREADED INSERTS: BRASS.
- 5 OBSOLETE PARTS: OBSOLETE CIS STREAMLINING PER D.RENAUD/D.SINISI

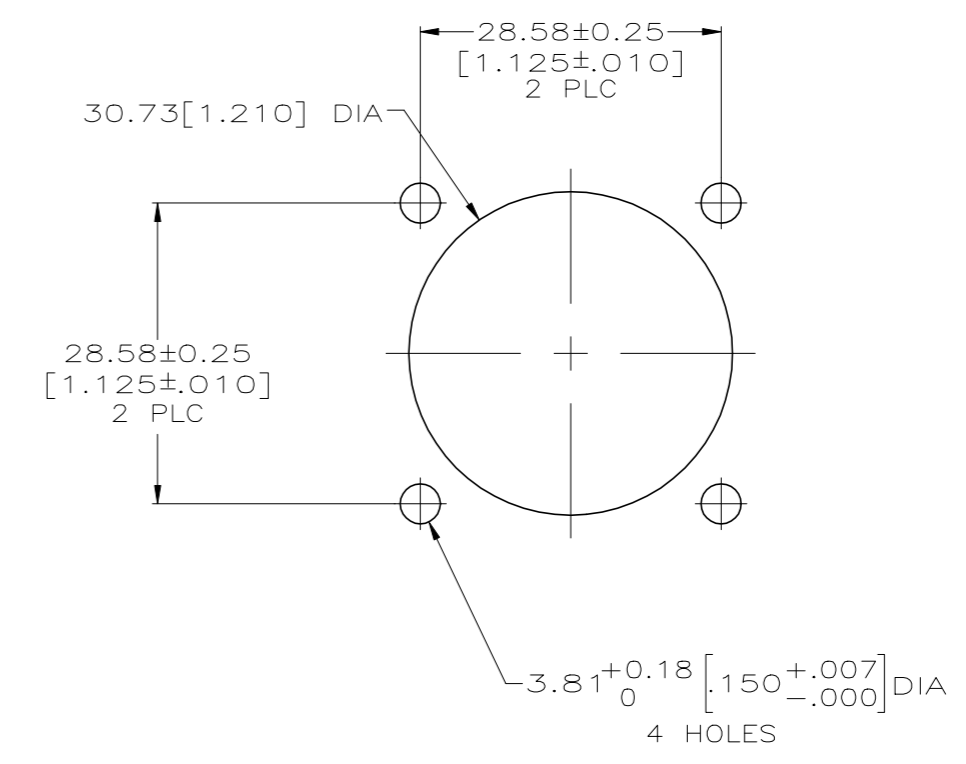
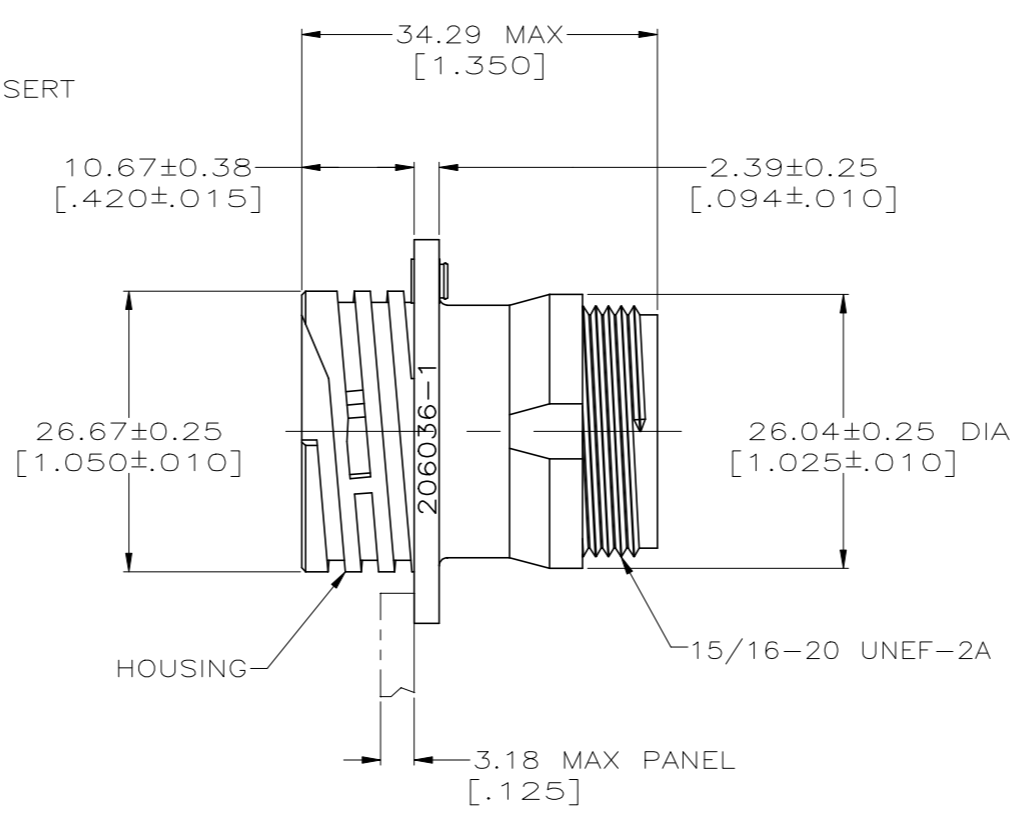
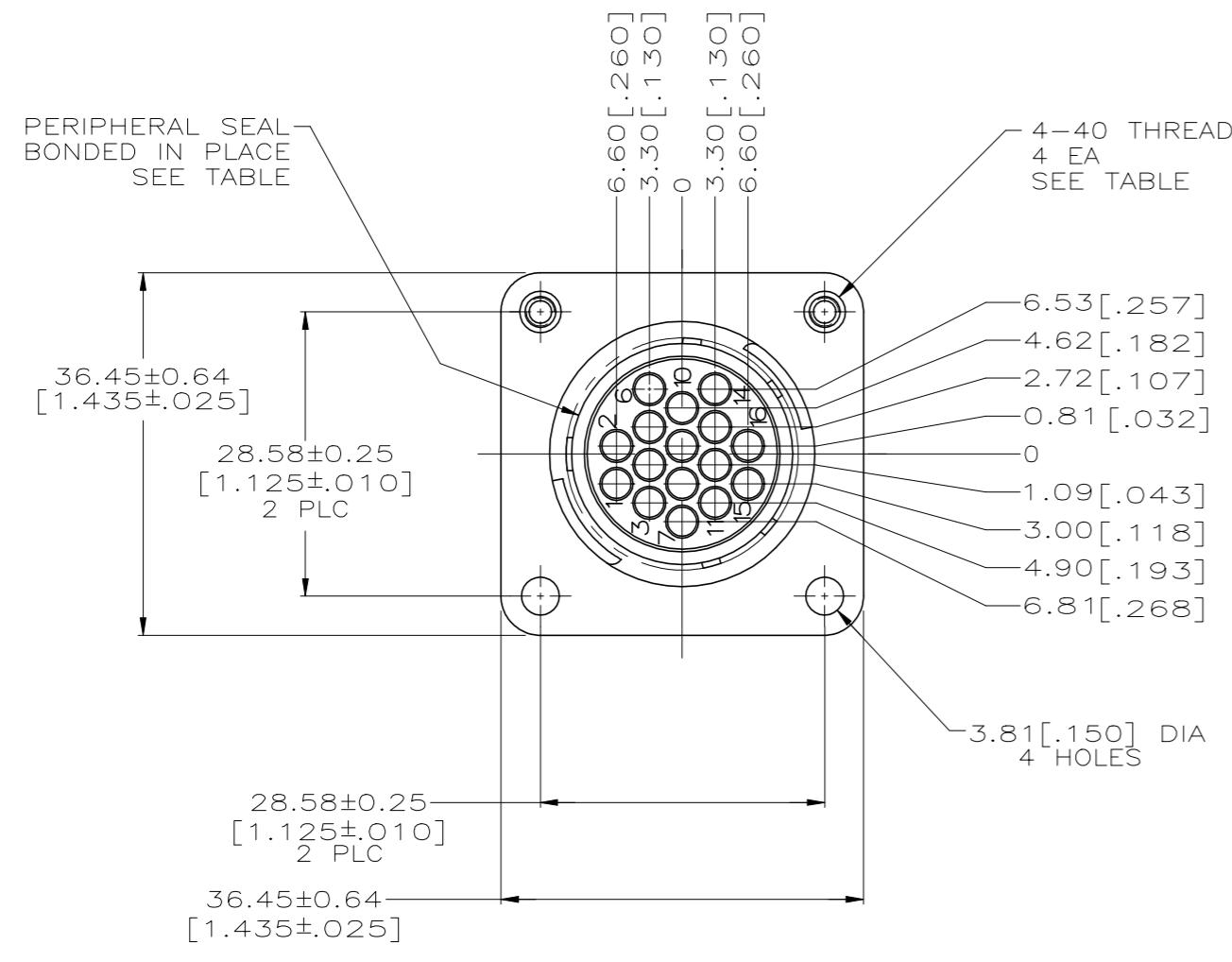

OBsolete	Material	Packaging	4-40 Threaded Inserts	Peripheral Seal	Part Number
△	STANDARD	NO	YES		206036-9-
△	STANDARD	YES	NO		206036-8
△	SMALL PACK	NO	NO		206036-7
△	STANDARD	NO	YES		206036-4
△	STANDARD	NO	NO		206036-1

THIS DRAWING IS A CONTROLLED DOCUMENT.

DIMENSIONS: MM(INCH)

TOLERANCES UNLESS OTHERWISE SPECIFIED:

0 PLC	±	-
1 PLC	±	-
2 PLC	±	0.13 [0.005]
3 PLC	±	-
4 PLC	±	-
ANGLES	±	-

MATERIAL: - FINISH: - WEIGHT: -

APPROVED: D. GELTZ 07/27/93, R. STONE 7-22-93, A. FRANTUM 8-12-93

NAME: RECEPTACLE HOUSING, STD SEX, SHELL SIZE 17, CPC

PRODUCT SPEC: 108-10024

APPLICATION SPEC: -

SIZE: A1 00779 C=206036

CUSTOMER DRAWING

SCALE: 2:1 SHEET 1 OF 3 REV U

STE TE Connectivity Ltd.

REVISIONS				
P	LTR	DESCRIPTION	DATE	DWN
-	-	SEE SHEET 1	-	-

- 1 CAVITY IDENTIFICATION ON FRONT AND REAR FACE.
- 2 WILL ACCEPT (3) TYPE XII PIN CONTACTS.
- 3 HOUSING: NYLON, BLACK.
PERIPHERAL SEAL: ELASTOMER, BLACK.

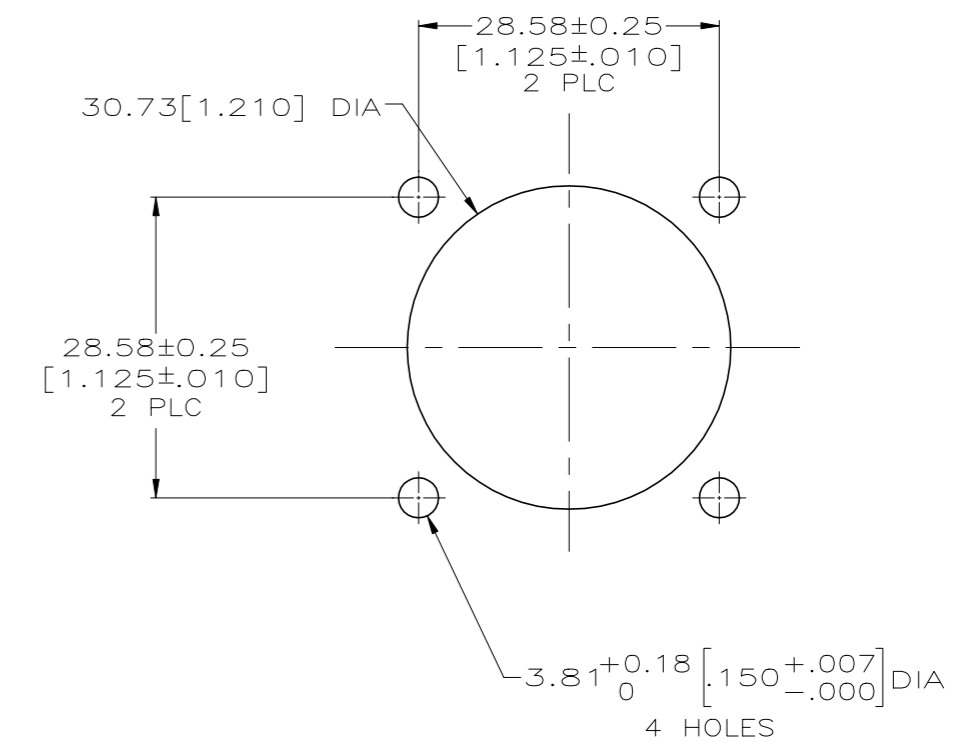
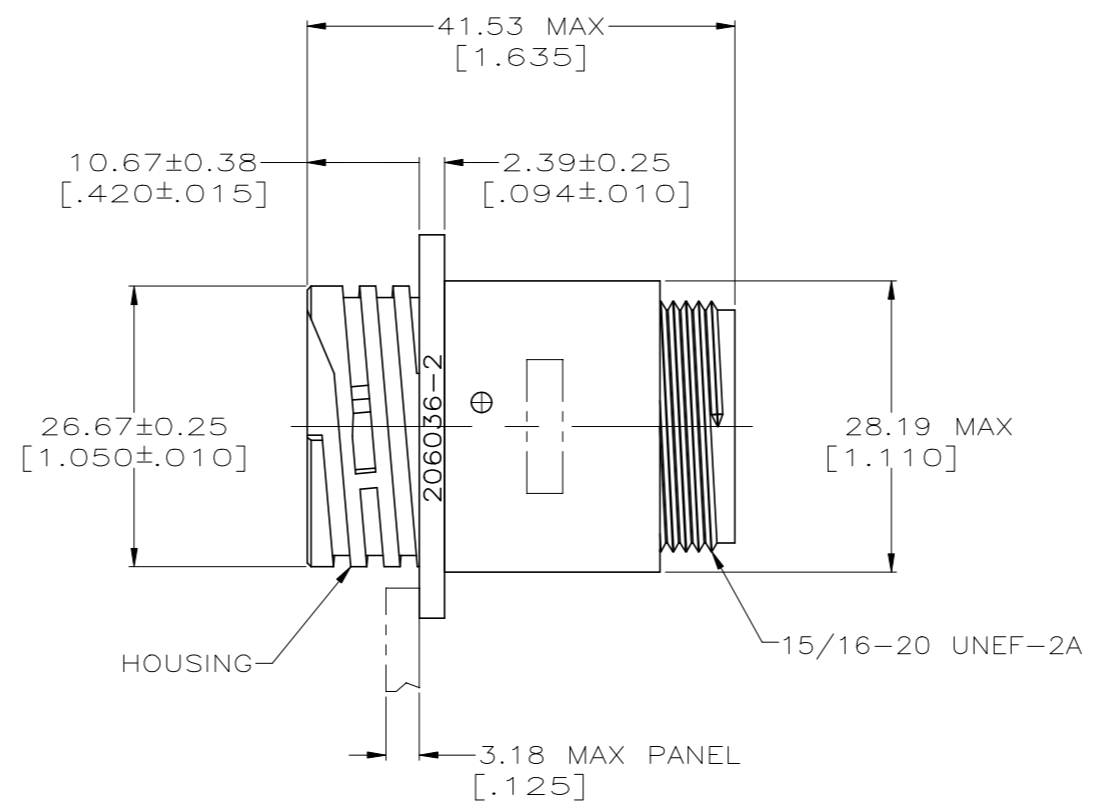
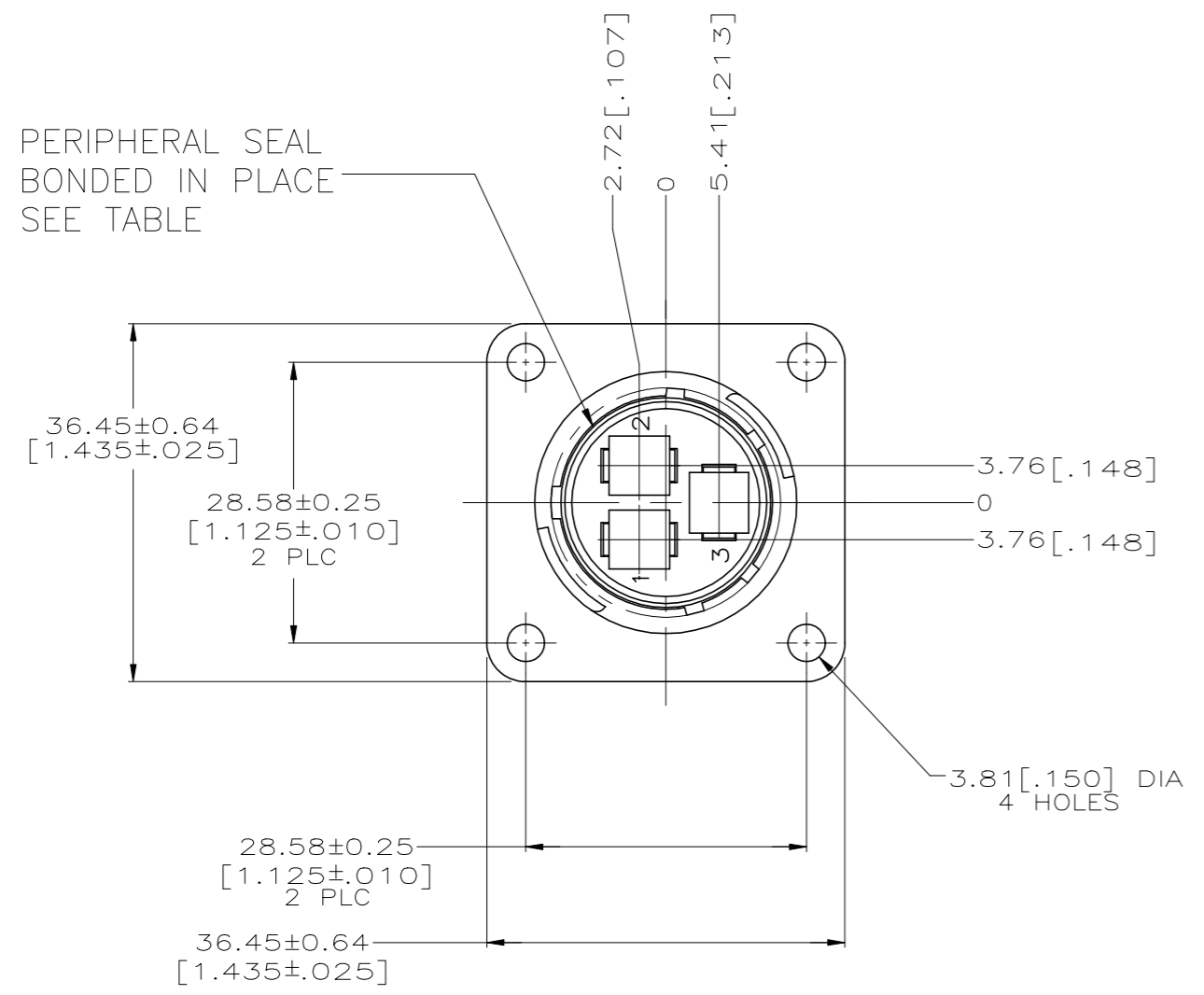

RECOMMENDED PANEL CUTOUT

PRELIMINARY		NO	YES	1-206036-6
		NO	NO	206036-2
MATERIAL	4-40 THREADED INSERTS	PERIPHERAL SEAL	PART NUMBER	
THIS DRAWING IS A CONTROLLED DOCUMENT.		DWN D. GELTZ 07/27/93	TE Connectivity Ltd. RECEPTACLE HOUSING, STD SEX, SHELL SIZE 17, CPC	
DIMENSIONS: MM(INCH)		CHK R. STONE 7-22-93		
TOLERANCES UNLESS OTHERWISE SPECIFIED:		APVD A. FRANTUM 8-12-93		
0 PLC ± - 1 PLC ± - 2 PLC ± 0.13 [.005] 3 PLC ± - 4 PLC ± - ANGLES ± -		NAME APPLICATION SPEC 108-10024		
MATERIAL	FINISH	WEIGHT	SIZE CASE CODE DRAWING NO A1 00779 C=206036	RESTRICTED TO
CUSTOMER DRAWING		SCALE 2:1	SHEET 2 OF 3	REV U

THIS DRAWING IS UNPUBLISHED. RELEASED FOR PUBLICATION
 (C) COPYRIGHT - By - ALL RIGHTS RESERVED.

REVISIONS				
P	LTR	DESCRIPTION	DATE	DWN
-	-	SEE SHEET 1	-	-

- 1 CAVITY IDENTIFICATION ON FRONT AND REAR FACE.
- 2 WILL ACCEPT (16) MULTIMATE PIN CONTACTS.
- 3 HOUSING: NYLON, BLACK.
PERIPHERAL SEAL: ELASTOMER, BLACK.
- 4 HOUSING: POLYESTER, PBT, BLACK.
PERIPHERAL SEAL: ELASTOMER, BLACK.

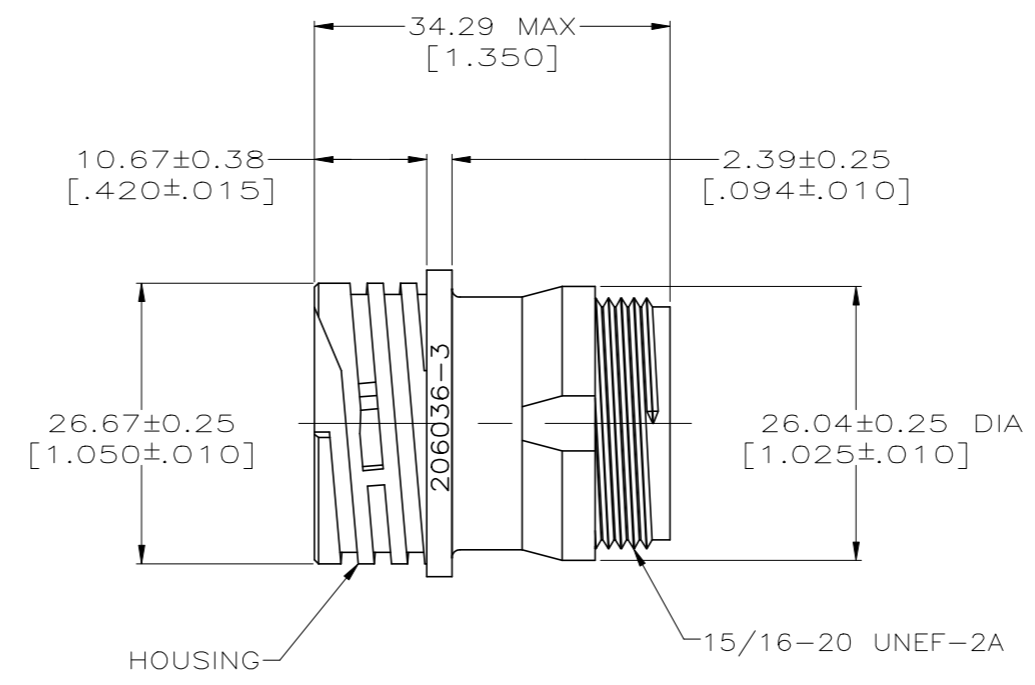
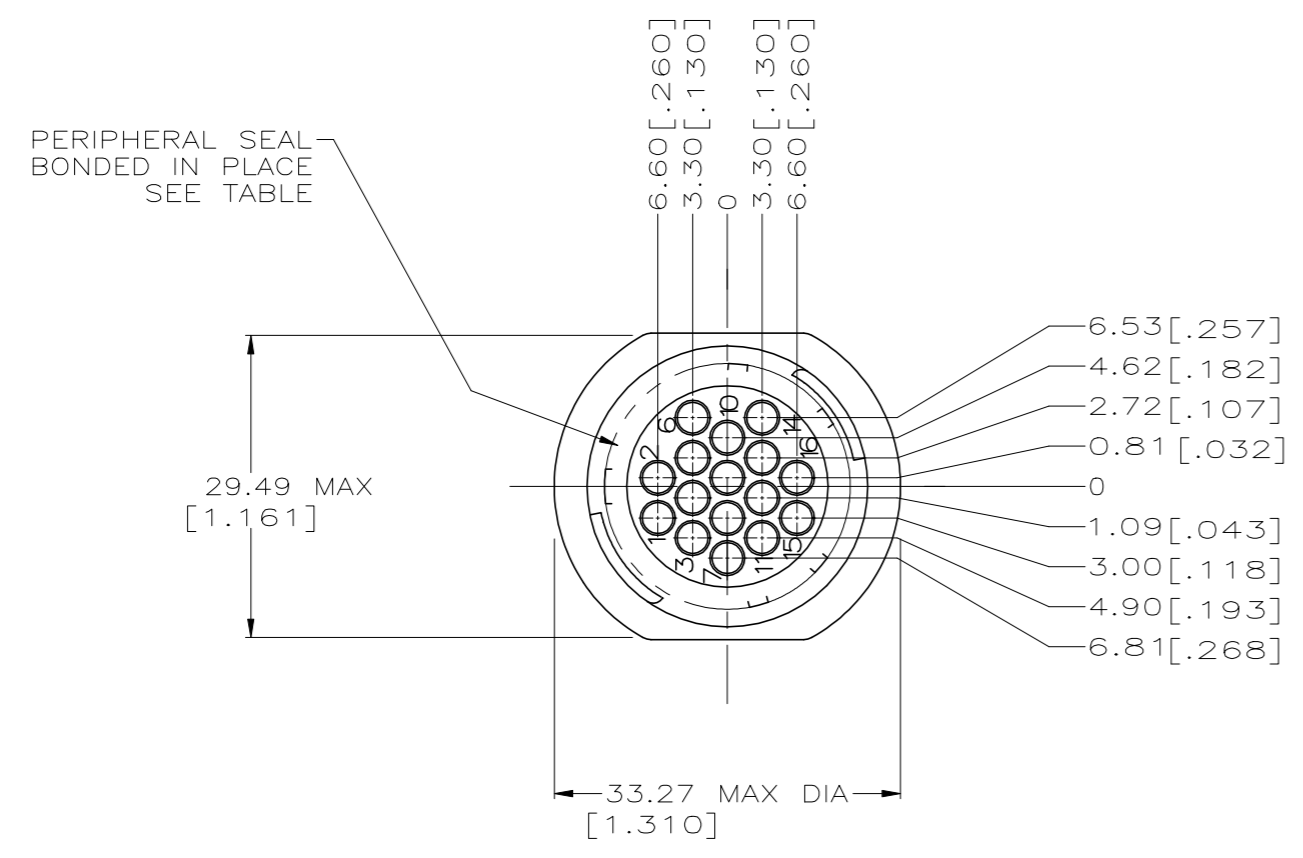

OBSOLETE	NO	1-206036-3
	YES	206036-5
	NO	206036-3
MATERIAL	PERIPHERAL SEAL	PART NUMBER

THIS DRAWING IS A CONTROLLED DOCUMENT. DWN: D. GELTZ 07/27/93
 CHK: R. STONE 7-22-93
 APVD: A. FRANTUM 8-12-93

STE TE Connectivity Ltd.

RECEPTACLE HOUSING, STD SEX, SHELL SIZE 17, CPC

108-10024

SIZE: A1 CAGE CODE: 00779 DRAWING NO: 206036

MATERIAL: FINISH: WEIGHT: CUSTOMER DRAWING SCALE: 2:1 SHEET 3 OF 3 REV U