

THIS DRAWING IS UNPUBLISHED. RELEASED FOR PUBLICATION
 © COPYRIGHT BY TYCO ELECTRONICS CORPORATION. ALL RIGHTS RESERVED.

| LOC | DIST | REVISIONS | | | |
|-----|------|-------------|-------------------------|---------|-------|
| P | LTR | DESCRIPTION | DATE | DWN | APVD |
| FT | 0 | M3 | REVISED PER ECO-06-3414 | 2/21/06 | SS SH |

NOTES:

- PART PACKAGED UNASSEMBLED.
- CABLE CLAMPING AREA ADJUSTABLE FROM .010 TO .161 SQ IN BY REVERSING CLAMPING INSERTS. (2 INSERTS SUPPLIED, -1 AND -3 ONLY)
- CABLE CLAMPING AREA ADJUSTABLE FROM .010 TO .161 SQ IN BY CHANGING CLAMPING INSERTS. (4 INSERTS SUPPLIED, -4 ONLY)
- .453 MAXIMUM CABLE OUTSIDE DIAMETER.
- BULK PACKAGED KITS TO BE ORDERED IN MULTIPLES OF 200 ONLY.
- NON-HEXAVALENT CHROMATE FINISH.

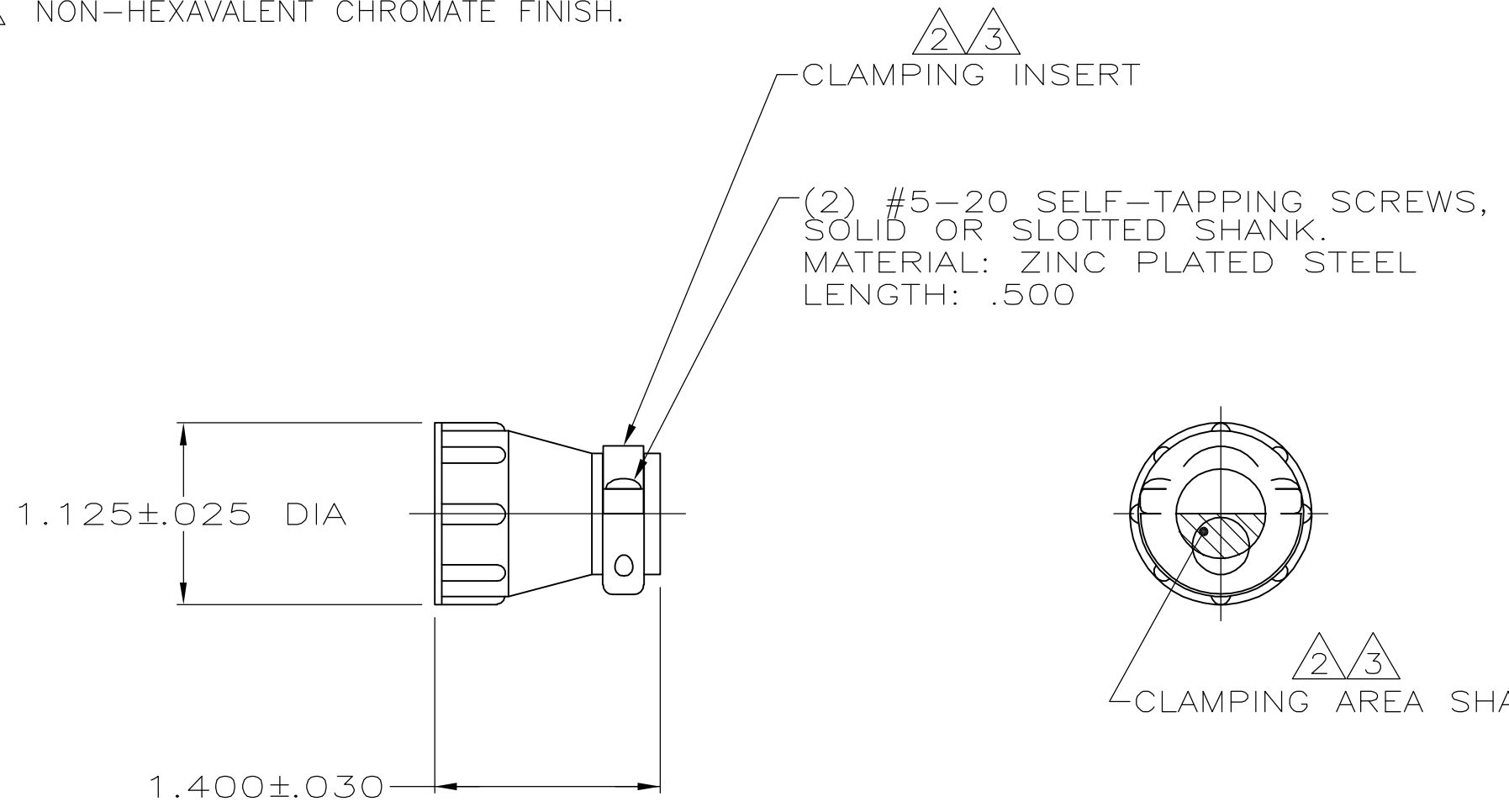

| | | |
|----------|------------|-------------|
| 6 | INDIVIDUAL | 1-206070-1 |
| 6 | 5 BULK | 1-206070-0 |
| 6 | SMALL PACK | 206070-9 |
| 6 | INDIVIDUAL | 206070-8 |
| | INDIVIDUAL | 206070-7 |
| | SMALL PACK | 206070-6 |
| OBSOLETE | 5 BULK | 206070-4 |
| | 5 BULK | 206070-3 |
| | INDIVIDUAL | 206070-1 |
| | PACKAGING | PART NUMBER |

| | | | | |
|--|--|------------------------------|---|--------------------|
| THIS DRAWING IS A CONTROLLED DOCUMENT. | | DWN A GRAFF 4/23/91 | Tyco Electronics Corporation Harrisburg, PA 17105-3608 | |
| DIMENSIONS: INCHES | | CHK W.G.LENKER 7-22-92 | NAME CABLE CLAMP KIT, STANDARD, SHELL SIZE 17, CPC | |
| TOLERANCES UNLESS OTHERWISE SPECIFIED: | | APVD - | PRODUCT SPEC 108-10024 | |
| 0 PLC ± - | | PRODUCT SPEC 108-10024 | APPLICATION SPEC - | |
| 1 PLC ± - | | APVD - | SIZE A3 | CAGE CODE 00779 |
| 2 PLC ± - | | PRODUCT SPEC 108-10024 | DRAWING NO C=206070 | RESTRICTED TO - |
| 3 PLC ± - | | APVD - | SCALE NTS | |
| 4 PLC ± - | | PRODUCT SPEC 108-10024 | SHEET 1 OF 1 | |
| ANGLES ± - | | APVD - | REV M3 | |
| FINISH - | | WEIGHT - | CUSTOMER DRAWING | |
| MATERIAL THERMOPLASTIC, | | | | |