

---

**Metrimate Signal Connector**

---

**1. SCOPE**

## 1.1. Content

I This specification covers performance, tests and quality requirements for Tyco Electronics Metrimate connectors. These connectors are designed to meet multi-national requirements where applicable and offer a wide range of uses for electronic and electrical equipment.

## 1.2. Qualification

I When tests are performed on subject product line, procedures specified in Figure 1 shall be used. All inspections shall be performed using applicable inspection plan and product drawing.

**2. APPLICABLE DOCUMENTS**

The following documents form a part of this specification to the extent specified herein. Unless otherwise specified, the latest edition of the document applies. In the event of conflict between the requirements of this specification and the product drawing, the product drawing shall take precedence. In the event of conflict between the requirements of this specification and the referenced documents, this specification shall take precedence.

## I 2.1. Tyco Electronics Documents

- I ● 109-1: General Requirements for Test Specifications
- I ● 109 Series: Test Specifications as indicated in Figure 1
- I ● 114-10004: Application Specification
- I ● 501-86: Qualification Test Report

**3. REQUIREMENTS**

## 3.1. Design and Construction

Product shall be of design, construction and physical dimensions specified on applicable product drawing.

## 3.2. Materials

- Contact: Brass or phosphor bronze, tin or gold plated
- Housing: Nylon or polyester

## 3.3. Ratings

- I ● Voltage: 600 volts AC or DC
- I ● Current: 7.5 amperes, theoretical value
- I ● Temperature: -55 to 130°C

3.4. Performance and Test Description

Product is designed to meet electrical, mechanical and environmental performance requirements specified in Figure 1. Unless otherwise specified, all tests shall be performed at ambient environmental conditions per Test Specification 109-1.

3.5. Test Requirements and Procedures Summary

Test Description	Requirement	Procedure
Examination of product.	Meets requirements of product drawing and Application Spec 114-10004.	Visual, dimensional and functional per applicable quality inspection plan.
ELECTRICAL		
Insulation resistance.	5000 megohms minimum initial.	AMP Spec 109-28-4. Test between adjacent contacts of unmated samples.
Dielectric withstanding voltage.	2 kvac at sea level.	AMP Spec 109-29-1. Test between adjacent contacts of unmated samples.
MECHANICAL		
Vibration, sinusoidal.	No discontinuities of 1 microsecond or longer duration. See Note.	AMP Spec 109-21-2. Subject mated samples to 10 G's between 10-500-10 Hz traversed in 15 minutes. 3 hours in each of 3 mutually perpendicular planes.
Physical shock.	No discontinuities of 1 microsecond or longer duration. See Note.	AMP Spec 109-26-1. Subject mated samples to 50 G's half-sine shock pulses of 11 milliseconds duration. 3 shocks in each direction applied along 3 mutually perpendicular planes, 18 total shocks.
Durability.	See Note.	AMP Spec 109-27. Mate and unmate samples for 250 cycles at maximum rate of 360 cycles per hour.
Contact retention.	Contacts shall withstand axial force without dislodging or damaging contact or connector. Contacts shall be capable of being removed and reinserted.	AMP Spec 109-30. Apply 10 pound axial load to contact after contact has been inserted and removed 5 times.
Mating force.	36 ounces maximum per contact.	AMP Spec 109-42, Condition A. Measure force necessary to mate samples at maximum rate of 1 inch per minute.

Figure 1 (cont)

Test Description	Requirement	Procedure																
Unmating force.	1 ounce minimum per contact.	AMP Spec 109-42, Condition A. Measure force necessary to unmate samples at maximum rate of 1 inch per minute.																
Housing panel retention.	<table border="1"> <thead> <tr> <th>Position</th> <th>Pounds Minimum</th> </tr> </thead> <tbody> <tr> <td>4</td> <td>50</td> </tr> <tr> <td>6</td> <td>50</td> </tr> <tr> <td>9</td> <td>50</td> </tr> <tr> <td>12</td> <td>60</td> </tr> <tr> <td>18</td> <td>60</td> </tr> <tr> <td>24</td> <td>80</td> </tr> <tr> <td>36</td> <td>80</td> </tr> </tbody> </table>	Position	Pounds Minimum	4	50	6	50	9	50	12	60	18	60	24	80	36	80	AMP Spec 109-49. Subject fully wired panel connector mounted in a vertical plane per Figure 3. Wires shall be bunched and specified axial force applied in direction shown. Hold for 1 minute, rotate 90 degrees and repeat. Mount connector in horizontal plane and apply axial load in each direction per Figure 4. Hold for 1 minute.
Position	Pounds Minimum																	
4	50																	
6	50																	
9	50																	
12	60																	
18	60																	
24	80																	
36	80																	
Housing locking strength.	10 pounds minimum.	AMP Spec 109-50. Apply 10 pound force to securely supported panel in direction as follows. Position plane so that mating faces are in a vertical plane, apply 10 pound force in straight pull in direction normal to plane of cable entrance.																
ENVIRONMENTAL																		
Thermal shock.	See Note.	AMP Spec 109-22. Subject unmated samples to 10 cycles between -55 and 105°C.																
Humidity, steady state.	See Note.	AMP Spec 109-23-2, Condition B. Subject mated samples to steady state humidity at 40°C and 90 to 95% RH.																

**NOTE** *Shall meet visual requirements, show no physical damage and shall meet requirements of additional tests as specified in Test Sequence in Figure 2.*

Figure 1 (end)

3.6. Product Qualification and Requalification Test Sequence

Test or Examination	Test Group (a)				
	1	2	3	4	5
	Test Sequence (b)				
Examination of product	1	1	1	1	1
Insulation resistance		4			
Dielectric withstanding voltage		5			
Vibration	3				
Physical shock	4				
Durability	2				
Contact retention			2		
Mating force	5				
Unmating force	6				
Housing panel retention					2
Housing locking strength				2	
Thermal shock		2			
Humidity, steady state		3			

**NOTE** (a) See paragraph 4.1.A.  
 (b) Numbers indicate sequence in which tests are performed.

Figure 2

**4. QUALITY ASSURANCE PROVISIONS**

4.1. Qualification Testing

A. Sample Selection

Samples shall be prepared in accordance with applicable Instruction Sheets and shall be selected at random from current production. All test groups shall consist of 5 each of 4 position plug and receptacle, all using dual diameter contacts or Type III+ contacts.

B. Test Sequence

Qualification inspection shall be verified by testing samples as specified in Figure 2.

4.2. Requalification Testing

If changes significantly affecting form, fit or function are made to product or manufacturing process, product assurance shall coordinate requalification testing, consisting of all or part of original testing sequence as determined by development/product, quality and reliability engineering.

4.3. Acceptance

Acceptance is based on verification that product meets the requirements of Figure 1. Failures attributed to equipment, test setup or operator deficiencies shall not disqualify product. When product failure occurs, corrective action shall be taken and samples resubmitted for qualification. Testing to confirm corrective action is required before resubmittal.

4.4. Quality Conformance Inspection

The applicable quality inspection plan will specify the sampling acceptable quality level to be used. Dimensional and functional requirements shall be in accordance with the applicable product drawing and this specification.

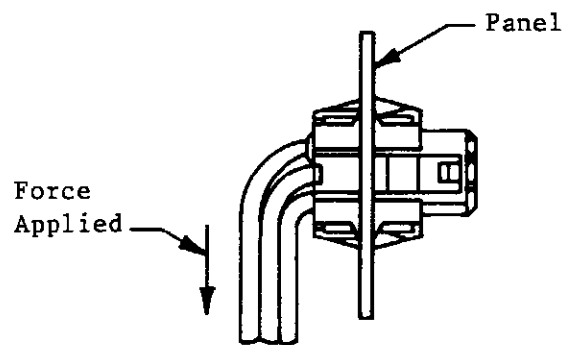

Figure 3  
Housing Panel Retention

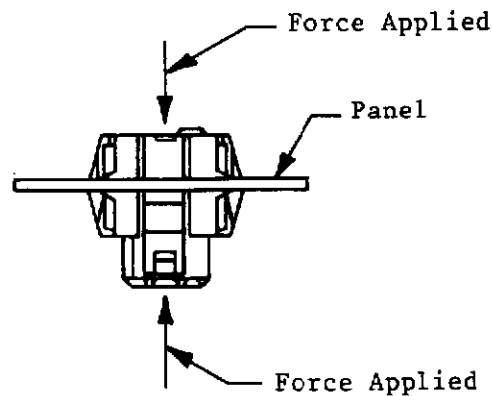

Figure 4  
Housing Panel Retention