

Distributed by:

JAMECO[®]
ELECTRONICS

www.Jameco.com ♦ 1-800-831-4242

The content and copyrights of the attached
material are the property of its owner.

Jameco Part Number 1965091

THIS DRAWING IS UNPUBLISHED. RELEASED FOR PUBLICATION
 © COPYRIGHT BY TYCO ELECTRONICS CORPORATION. ALL RIGHTS RESERVED.

LOC		DIST		REVISIONS					
FT		0		P	LTR	DESCRIPTION	DATE	DWN	APVD
				P		EC 0G3B-0361-03	02MAY03	DJM	SH

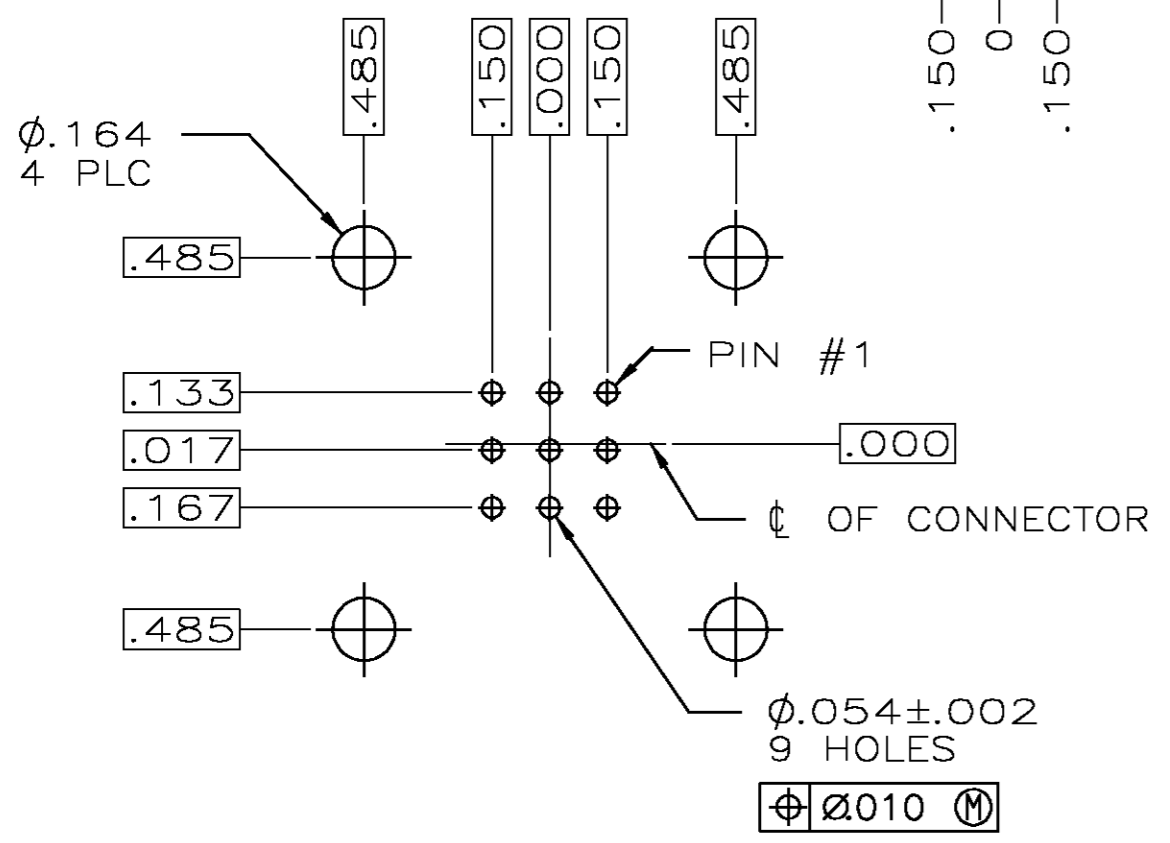
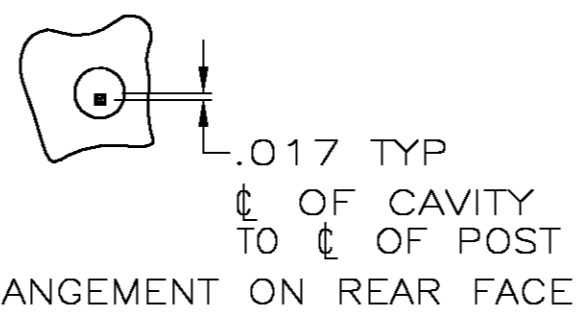
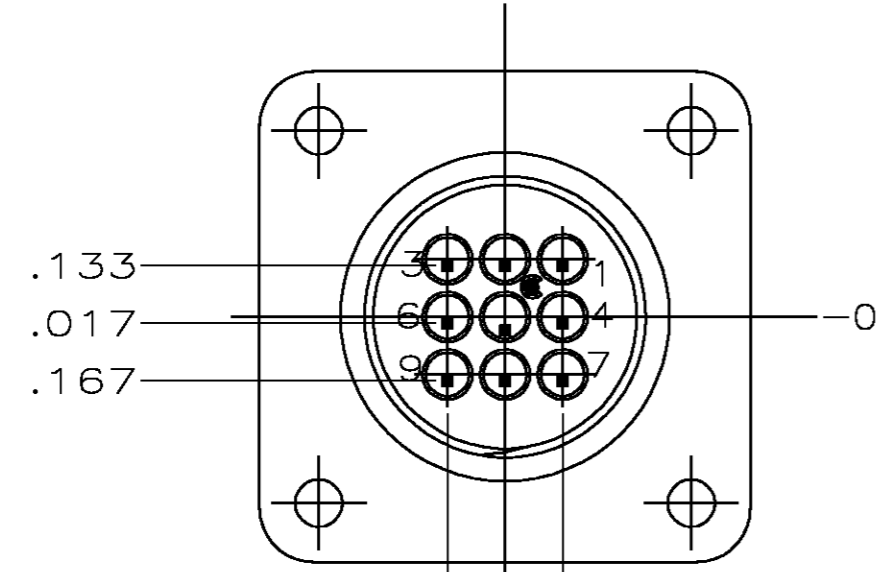
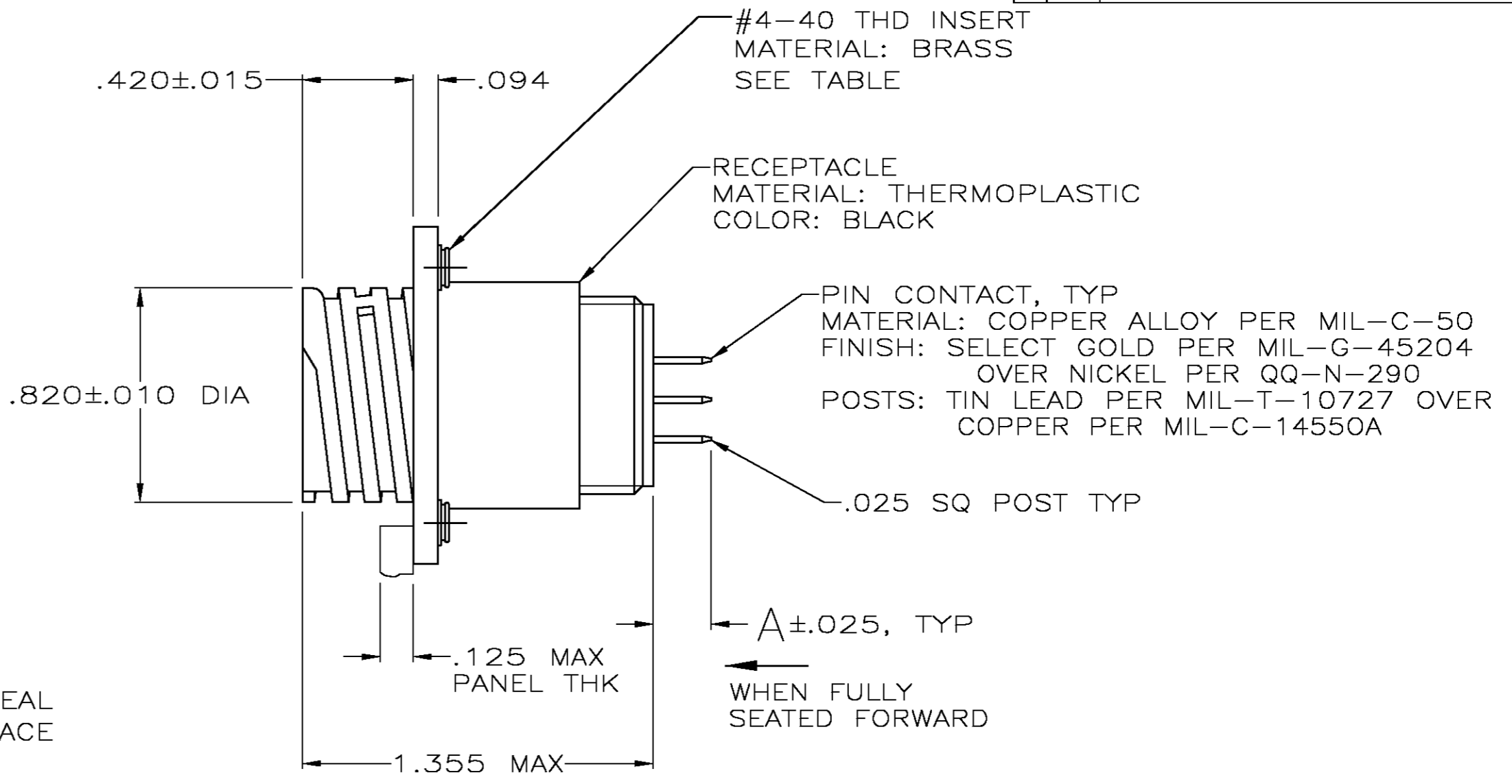
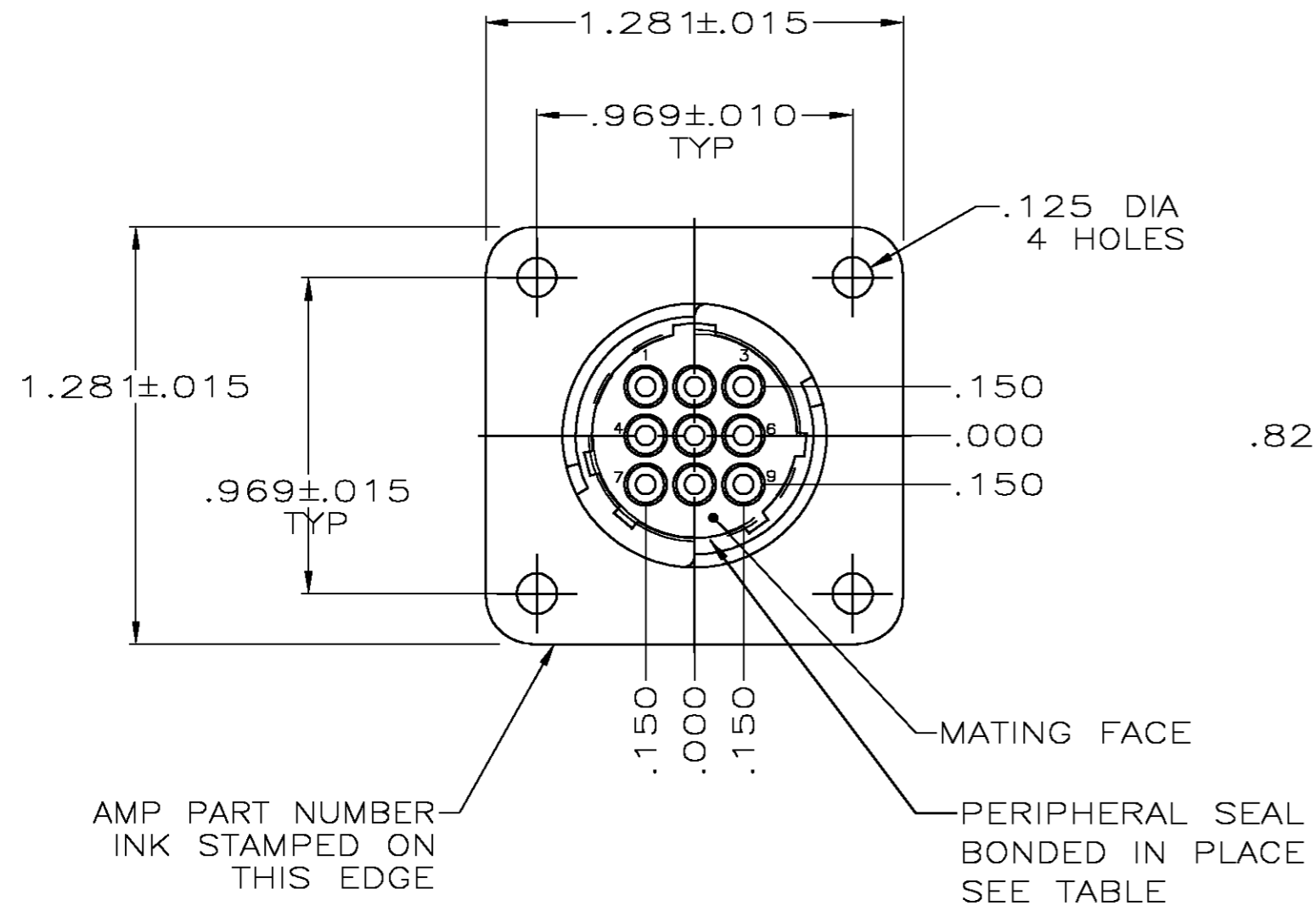

- ① 1-66460-0 WILL BE SELECTIVELY LOADED INTO POSITIONS 2, 4, 6, 7, 9 AND 66464-3 WILL BE LOADED INTO POSITIONS 1, 3, 5, 8 OF THE HOUSING.
- ② LOAD ALL POSITIONS EXCEPT POSITION NUMBER 4.
- ③ LEAD-FREE CONTACTS.

	③	.220	NO	NO	208223-9
PRELIMINARY		.220	YES	NO	208223-8
PRELIMINARY	②	.220	NO	NO	208223-7
PRELIMINARY		.618	NO	YES	208223-6
PRELIMINARY		.220	YES	YES	208223-5
	①	.220	NO	NO	208223-4
		.220	NO	YES	208223-3
OBSOLETE		.429	NO	NO	208223-2
		.220	NO	NO	208223-1
	A	PERIPHERAL SEAL	THREADED INSERTS	PART NUMBER	

THIS DRAWING IS A CONTROLLED DOCUMENT.

DIMENSIONS: INCHES	TOLERANCES UNLESS OTHERWISE SPECIFIED:	DWN R.LEE BG 6-22-91	CHK W.G.LENKER 4-14-92	Tyco Electronics Corporation Harrisburg, Pa. 17105-3608	
	0 PLC ± -	APVD -	NAME	RECEPTACLE ASSEMBLY, POSTED, STD SEX, SERIES 1, 13-9, CPC	
	1 PLC ± -	PRODUCT SPEC 108-10024	SIZE A2	CAGE CODE 00779	DRAWING NO C=208223
	2 PLC ± -	APPLICATION SPEC	WEIGHT -	RESTRICTED TO -	
	3 PLC ± .005		CUSTOMER DRAWING	SCALE 2:1	SHEET 1 OF 1
	4 PLC ± -			REV P	
	ANGLES ± -				
MATERIAL SEE CALLOUT	FINISH SEE CALLOUT				

RECOMMENDED P.C. BOARD LAYOUT