

LOC	DIST	REVISIONS			
		REV	DATE	BY	APPV
	00	A	02DEC2011	TD	TD
		A1	07AUG2012	DS	TD
		A2	01OCT2012	DS	DR
		B	27MAR2013	TD	TD

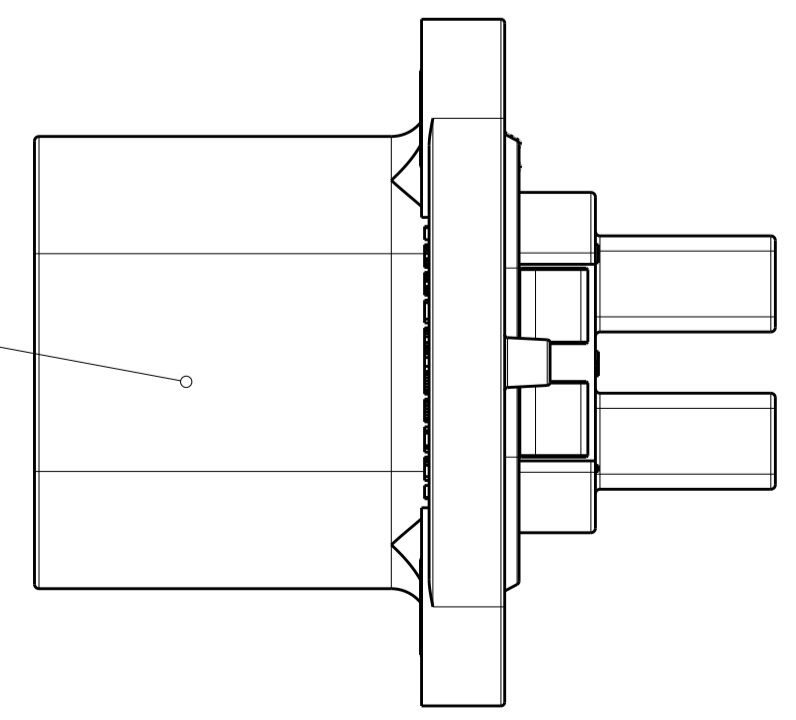

- 1 IDENTIFICATION MARKING ON THIS SURFACE CONTAINS ASSEMBLY P/N AND DATE CODE (YYDD). TEXT ORIENTATION, SIZE, AND LOCATION CAN VARY AS LONG AS TEXT IS ON SURFACE SHOWN AND READABLE.
- 2 SHIELD SEAM CAN BE POSITIONED AS SHOWN OR ROTATED 180° FROM POSITION SHOWN.
- 3 DELETED
- 4 THESE DIMENSIONS DEFINE FASTENER SIZE LIMITS FOR PROPER COMPONENT FUNCTIONALITY. END USER MUST ENSURE FASTENER AND/OR WASHER DIAMETER IS 8.6 MM MIN FOR PROPER RETENTION. THESE ARE NOT PRODUCT FEATURES - NO INSPECTION REQUIRED FOR THESE ITEMS.
- 5 SURFACE FINISH APPLIES TO AREAS SHOWN IN MOUNTING INTERFACE SPECIFICATION
- 6. USE WITH 2.8MM BLADE TERMINAL P/N:
2-2141598-2 FOR 1.0 - 2.5MM² WIRE
2-2141600-2 FOR >2.5 - 4.0MM² WIRE
- 7. USE WITH MOS RECEPTACLE P/N:
963715-6, 963715-5, 928999-6 OR 928999-5,
DEPENDING ON WIRE SIZE AND MATING PLUG USED
- 8 NOTE DELETED
- 9 NOTE DELETED

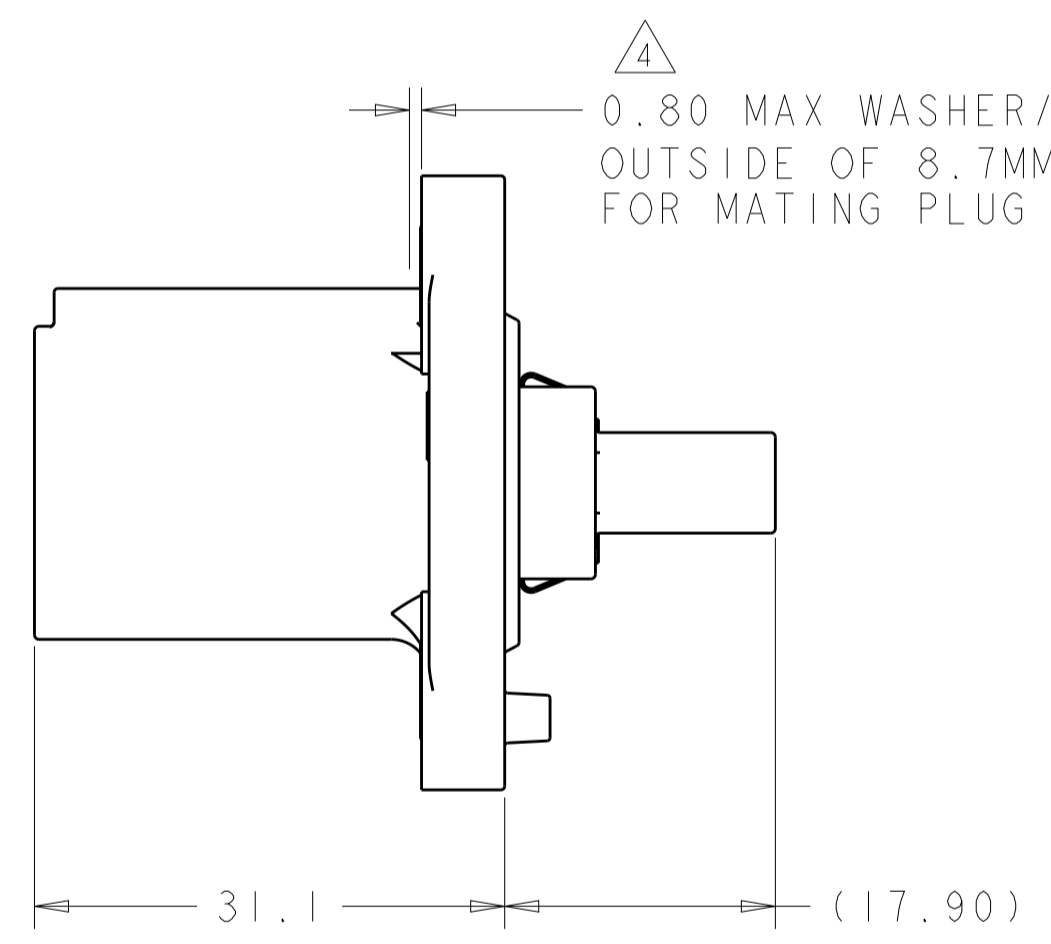
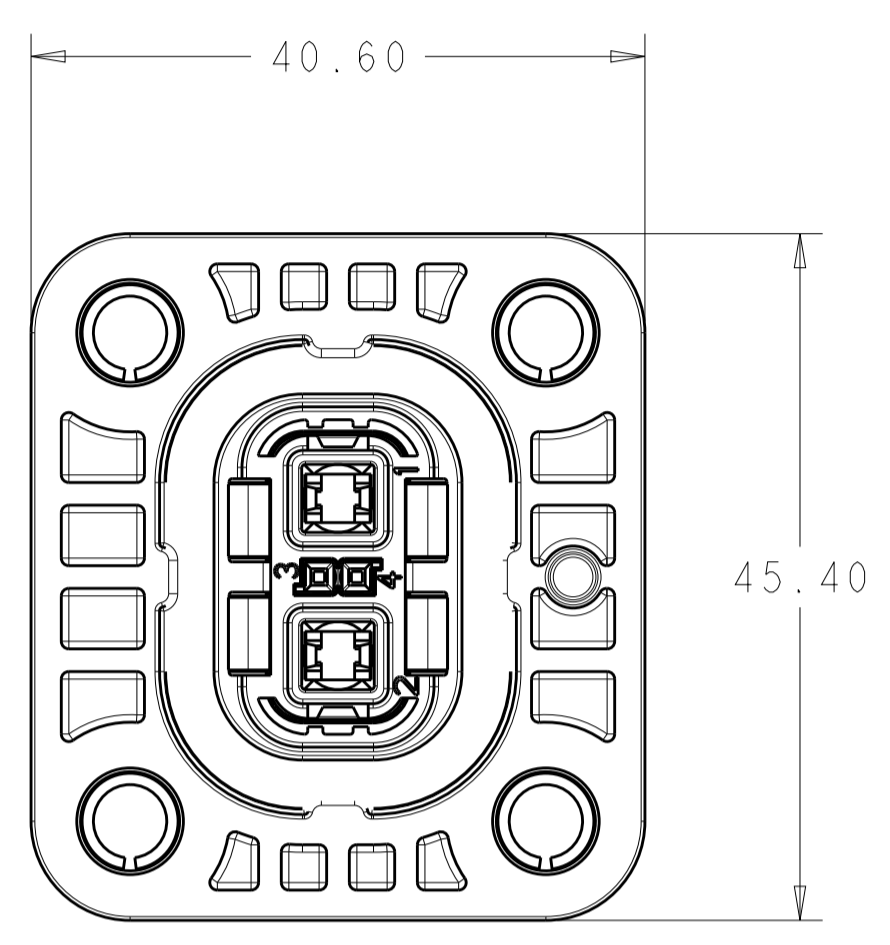
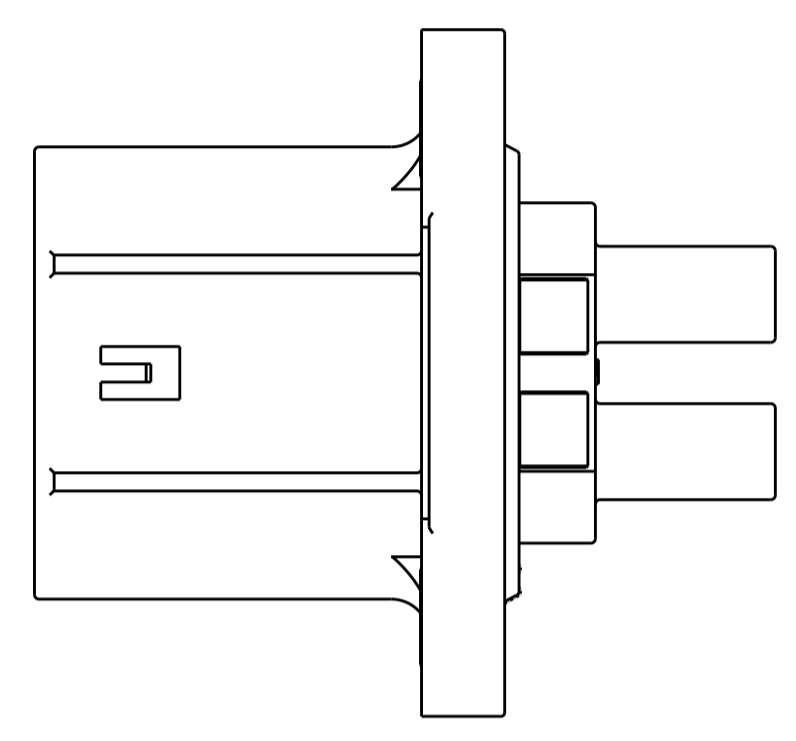
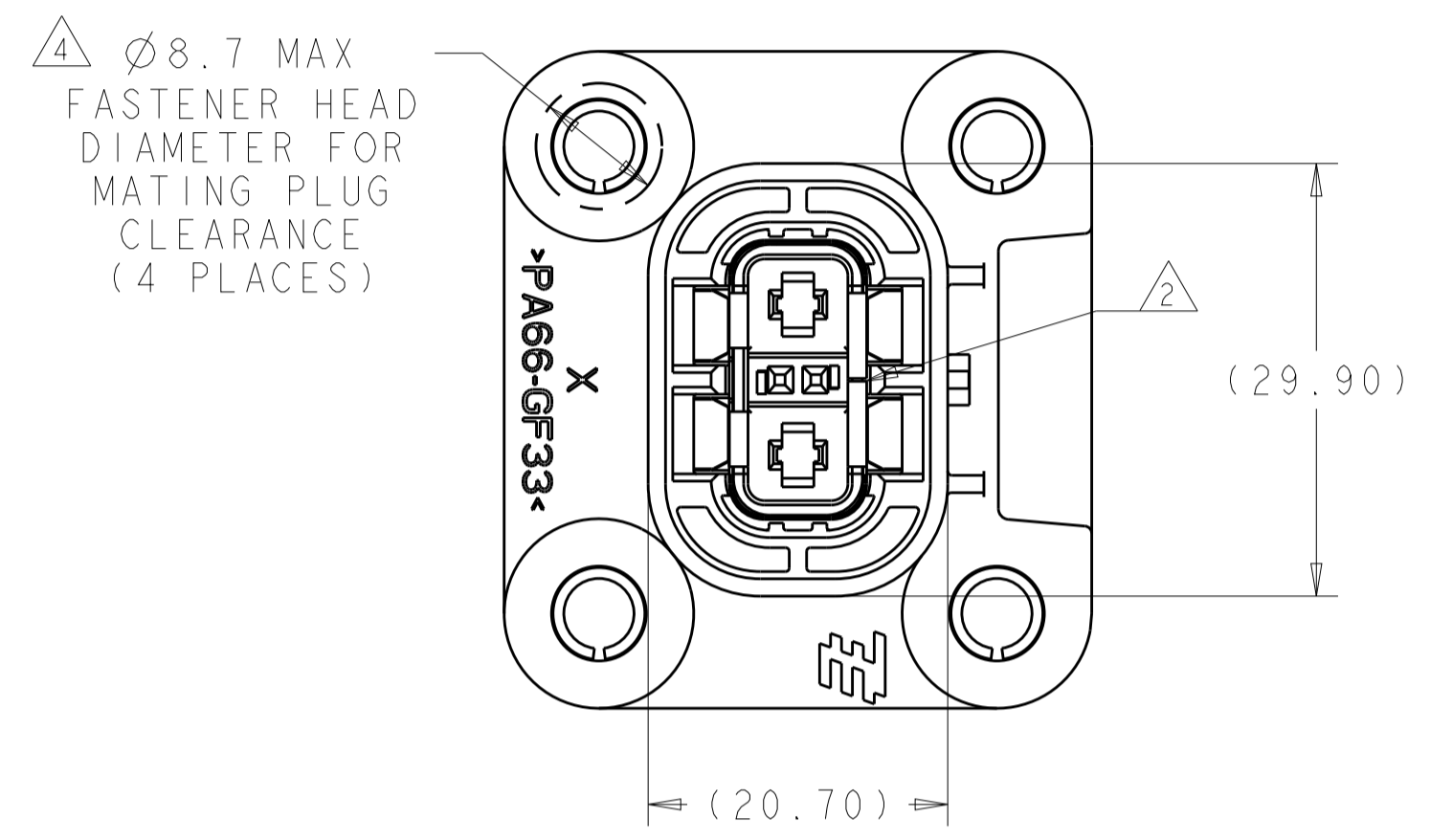
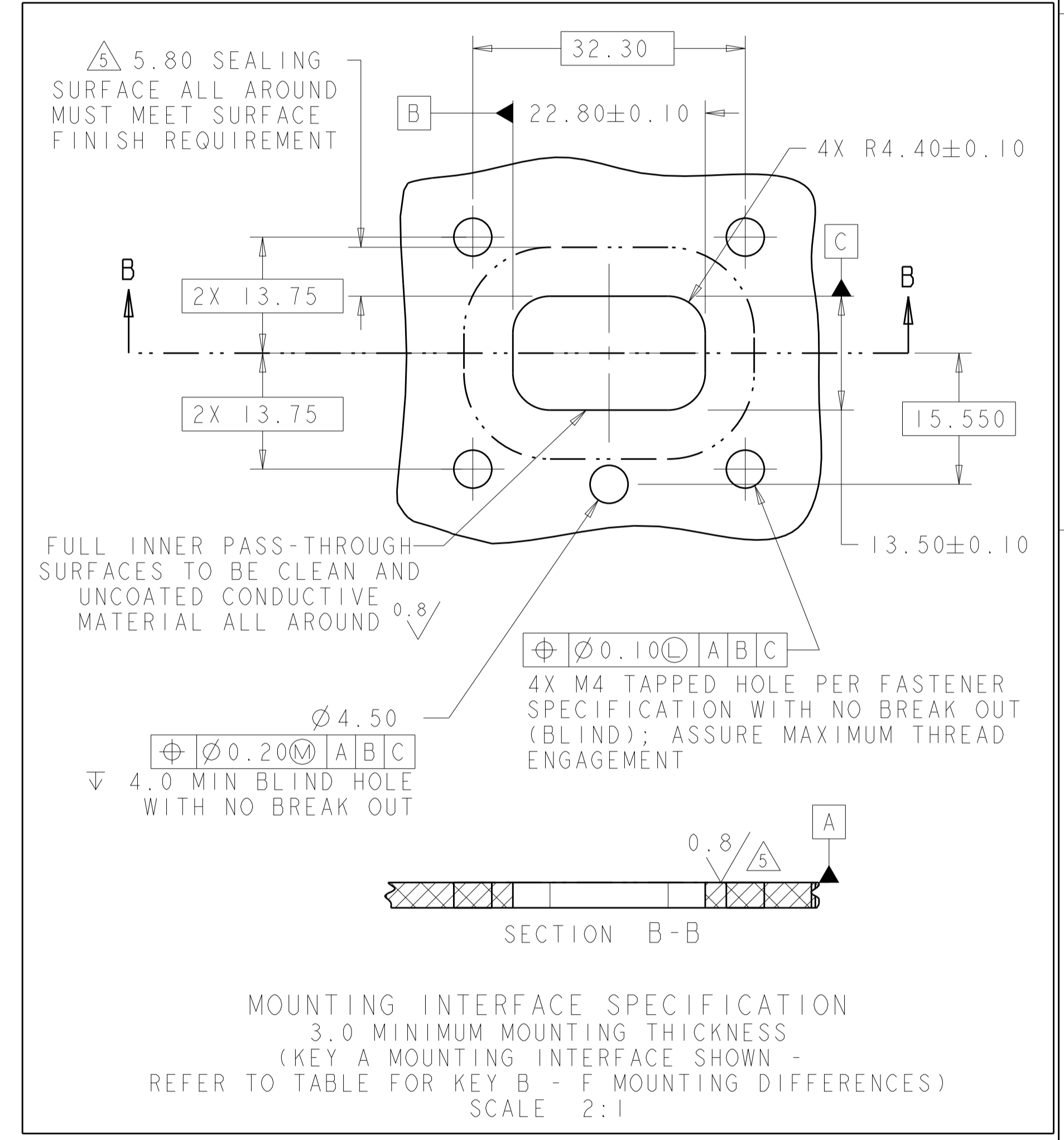
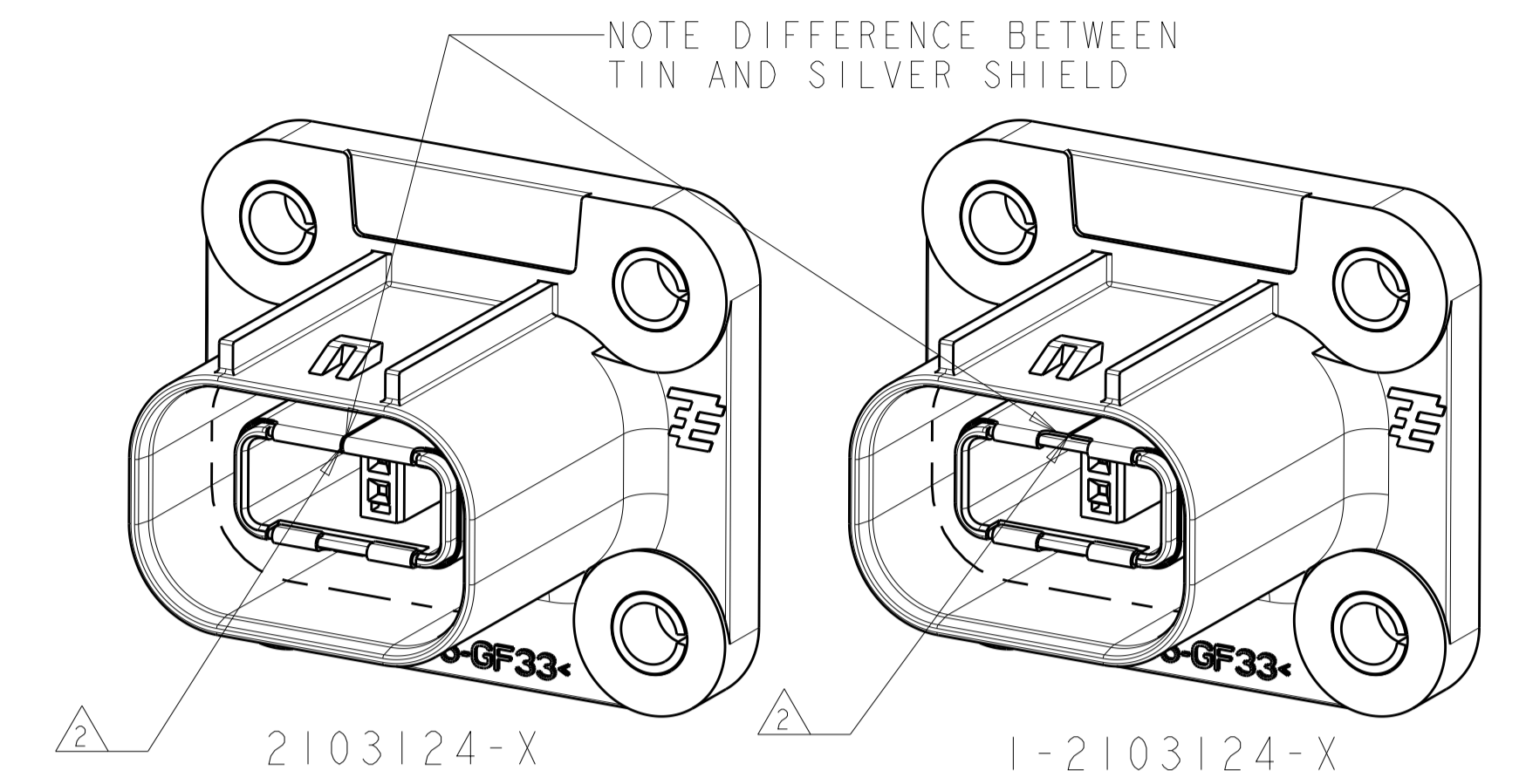

SHIELD FINISH	INDEX	REVISION	PART NO
SILVER	F	B	1-2103124-6
SILVER	E	B	1-2103124-5
SILVER	D	B	1-2103124-4
SILVER	B	B	1-2103124-2
SILVER	A	B	1-2103124-1
TIN	F	B	2103124-6
TIN	E	B	2103124-5
TIN	D	B	2103124-4
TIN	B	B	2103124-2
TIN	A	B	2103124-1

THIS DRAWING IS A CONTROLLED DOCUMENT. DIMENSIONING AND TOLERANCING PER ASME Y14.5M-2009.

DMN T. DEWILTE 30SEP2010
 CHK T. DEWILTE 30SEP2010
 APVD T. DEWILTE 15APR2011

PRODUCT SPEC
 APPLICATION SPEC

NAME: HVA280 2P HEADER ASSY W/HVIL - PLASTIC 1 PIECE CHART DRAWING

SIZE: A1 CAGE CODE: 100779 DRAWING NO: 2103124

WEIGHT: 22.7 g

CUSTOMER DRAWING

SCALE: 2:1 SHEET 1 OF 2 REV B

LOC	DIST	REVISIONS			
P	LTN	DESCRIPTION	DATE	DMN	APVD
-	-	SEE SHEET 1	-	-	-

	X-2103124-1 (KEY A)	X-2103124-2 (KEY B)	X-2103124-4 (KEY D)	X-2103124-5 (KEY E)	X-2103124-6 (KEY F)
FRONT VIEW					
SIDE VIEW					
REAR VIEW					
INTERFACE VIEW - MOUNTING SIDE					
	KEY A MOUNTING INTERFACE	KEY B MOUNTING INTERFACE	KEY D MOUNTING INTERFACE	KEY E MOUNTING INTERFACE	KEY F MOUNTING INTERFACE

THIS DRAWING IS A CONTROLLED DOCUMENT. DIMENSIONING AND TOLERANCING PER ASME Y14.5M-2009.		DMN: T. DEWILITE 30SEP2010	TE Connectivity
DIMENSIONS: mm		CHK: T. DEWILITE 30SEP2010	
TOLERANCES UNLESS OTHERWISE SPECIFIED:		APVD: T. DEWILITE 15APR2011	NAME: HVA280 2P HEADER ASSY
0 PLC	±0.50	PRODUCT SPEC	W/HVIL - PLASTIC 1 PIECE
1 PLC	±0.50	APPLICATION SPEC	CHART DRAWING
2 PLC	±0.15	SIZE	CAGE CODE DRAWING NO
3 PLC	±0.05	WEIGHT	RESTRICTED TO
4 PLC	±0.05	22.7 g	A100779C=2103124
ANGLES	±0.3	CUSTOMER DRAWING	SCALE 2:1 SHEET 2 OF 2 REV B
FINISH	±0.3		